

WOODHEAD PUBLISHING SERIES IN TEXTILES

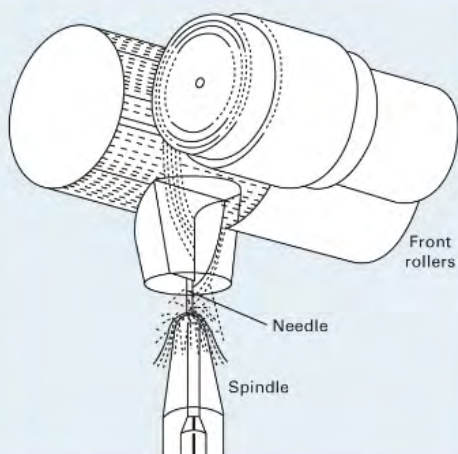

# Advances in yarn spinning technology

Edited by C. A. Lawrence



The Textile Institute

**WP**  
WOODHEAD  
PUBLISHING

# Advances in yarn spinning technology

## **The Textile Institute and Woodhead Publishing**

The Textile Institute is a unique organisation in textiles, clothing and footwear. Incorporated in England by a Royal Charter granted in 1925, the Institute has individual and corporate members in over 90 countries. The aim of the Institute is to facilitate learning, recognise achievement, reward excellence and disseminate information within the global textiles, clothing and footwear industries.

Historically, The Textile Institute has published books of interest to its members and the textile industry. To maintain this policy, the Institute has entered into partnership with Woodhead Publishing Limited to ensure that Institute members and the textile industry continue to have access to high calibre titles on textile science and technology.

Most Woodhead titles on textiles are now published in collaboration with The Textile Institute. Through this arrangement, the Institute provides an Editorial Board which advises Woodhead on appropriate titles for future publication and suggests possible editors and authors for these books. Each book published under this arrangement carries the Institute's logo.

Woodhead books published in collaboration with The Textile Institute are offered to Textile Institute members at a substantial discount. These books, together with those published by The Textile Institute that are still in print, are offered on the Woodhead web site at: [www.woodheadpublishing.com](http://www.woodheadpublishing.com). Textile Institute books still in print are also available directly from the Institute's web site at: [www.textileinstitutebooks.com](http://www.textileinstitutebooks.com).

A list of Woodhead books on textiles science and technology, most of which have been published in collaboration with The Textile Institute, can be found towards the end of the contents pages.

Woodhead Publishing Series in Textiles: Number 99

# Advances in yarn spinning technology

---

Edited by  
C. A. Lawrence



The Textile Institute



Oxford Cambridge Philadelphia Ne/w Delhi

Published by Woodhead Publishing Limited in association with The Textile Institute  
Woodhead Publishing Limited, Abington Hall, Granta Park, Great Abington,  
Cambridge CB21 6AH, UK  
www.woodheadpublishing.com

Woodhead Publishing, 525 South 4th Street #241, Philadelphia, PA 19147, USA

Woodhead Publishing India Private Limited, G-2, Vardaan House, 7/28 Ansari Road,  
Daryaganj, New Delhi – 110002, India  
www.woodheadpublishingindia.com

First published 2010, Woodhead Publishing Limited

© Woodhead Publishing Limited, 2010

The authors have asserted their moral rights.

This book contains information obtained from authentic and highly regarded sources. Reprinted material is quoted with permission, and sources are indicated. Reasonable efforts have been made to publish reliable data and information, but the authors and the publisher cannot assume responsibility for the validity of all materials. Neither the authors nor the publisher, nor anyone else associated with this publication, shall be liable for any loss, damage or liability directly or indirectly caused or alleged to be caused by this book.

Neither this book nor any part may be reproduced or transmitted in any form or by any means, electronic or mechanical, including photocopying, microfilming and recording, or by any information storage or retrieval system, without permission in writing from Woodhead Publishing Limited.

The consent of Woodhead Publishing Limited does not extend to copying for general distribution, for promotion, for creating new works, or for resale. Specific permission must be obtained in writing from Woodhead Publishing Limited for such copying.

Trademark notice: Product or corporate names may be trademarks or registered trademarks, and are used only for identification and explanation, without intent to infringe.

British Library Cataloguing in Publication Data

A catalogue record for this book is available from the British Library.

ISBN 978-1-84569-444-9 (print)

ISBN 978-0-85709-021-8 (online)

ISSN 2042-0803 Woodhead Publishing Series in Textiles (print)

ISSN 2042-0811 Woodhead Publishing Series in Textiles (online)

The publisher's policy is to use permanent paper from mills that operate a sustainable forestry policy, and which has been manufactured from pulp which is processed using acid-free and elemental chlorine-free practices. Furthermore, the publisher ensures that the text paper and cover board used have met acceptable environmental accreditation standards.

Typeset by Replika Press Pvt Ltd, India

Printed by TJI Digital, Padstow, Cornwall, UK

# Contents

---

<i>Contributor contact details</i>	<i>xi</i>
<i>Woodhead Publishing Series in Textiles</i>	<i>xiii</i>
<b>Part I Introduction to yarn spinning and structure</b>	
1 Overview of developments in yarn spinning technology C. A. LAWRENCE, University of Leeds, UK	3
1.1 Introduction	3
1.2 Early history	4
1.3 Early developments	9
1.4 Ring spinning	22
1.5 Modern spinning methods and developments: an overview	25
1.6 Twist spinning methods	26
1.7 Wrap spinning methods	34
1.8 Conclusions	39
1.9 References	40
2 Fundamental principles of ring spinning of yarns R. S. RENGASAMY, IIT Delhi, India	42
2.1 Introduction	42
2.2 Basic principles of spinning	43
2.3 Ring spinning	44
2.4 Ring spinning systems	49
2.5 Description of the ring spinning process	49
2.6 Post-spinning	72
2.7 Applications of ring spinning	74
2.8 Future trends	76
2.9 References and bibliography	77

vi	Contents	
3	Fundamental principles of open end yarn spinning A. DAS and R. ALAGIRUSAMY, IIT Delhi, India	79
3.1	Introduction	79
3.2	Commercial open end spinning systems: rotor spinning	81
3.3	Friction spinning	84
3.4	Vortex spinning	93
3.5	Conclusions	98
3.6	References	98
4	Blending and composite yarn spinning M. R. MAHMOUDI, University of Leeds, UK	102
4.1	Introduction: the purpose of blending	102
4.2	Blending and yarn properties	105
4.3	Blending methods	108
4.4	Carding	112
4.5	Measuring the effectiveness of blending	115
4.6	References and sources of further information	118
5	Yarn structure and properties from different spinning techniques G. K. TYAGI, The Technological Institute of Textile and Sciences, India	119
5.1	Introduction	119
5.2	Ring spun yarns	120
5.3	Rotor spun yarns	126
5.4	Air-jet spun yarns	134
5.5	Friction spun yarns	141
5.6	Wrap spun yarns	146
5.7	Structure–property relationships of staple spun yarns	147
5.8	The plying of staple fibre yarns	149
5.9	Future trends	150
5.10	Acknowledgements	151
5.11	References	151
6	Yarn structural requirements for knitted and woven fabrics H. M. BEHERY, Clemson University, USA	155
6.1	Introduction	155
6.2	Fiber types and their classification	156
6.3	Principal requirements for knitted fabric end uses	156
6.4	Principal requirements for woven fabric end uses	161
6.5	Yarn types and their classification	167

6.6	Fiber/yarn/manufacturing process interactions and their effect on yarn structure	176
6.7	Survey of yarn properties	177
6.8	Criteria for choice of fibers and yarns to suit fabric end use and performance	179
6.9	Conclusions	180
6.10	Sources of further information and advice	181
6.11	References and bibliography	181
6.12	Appendix: Glossary and definitions of physical and mechanical properties of fibers, yarns and fabrics	182

**Part II Advances in particular yarn spinning technologies**

7	Developments in ring spinning R. S. RENGASAMY, IIT Delhi, India	193
7.1	Introduction	193
7.2	Main technologies of spinning	194
7.3	Advantages and limitations of ring spinning	194
7.4	Developments in ring spinning	195
7.5	Future trends	216
7.6	References and bibliography	216
8	Siro and Solo spinning P. R. LAMB and X. WANG, Deakin University, Australia	217
8.1	Introduction	217
8.2	Background	217
8.3	Sirospun	219
8.4	Solospun	225
8.5	Types of fibres used	227
8.6	Yarn quality and properties achieved	228
8.7	Advantages and limitations	229
8.8	Applications	231
8.9	The development of ancillary processes	232
8.10	Future trends	233
8.11	Sources of further information and advice	234
8.12	References	234
9	Compact spinning technology M. A. M. EL-SAYED and S. H. SANAD, Agricultural Research Centre, Cotton Research Institute, Egypt	237
9.1	Introduction	237
9.2	Types of fibre used	247

viii	Contents	
9.3	Yarn quality and properties	249
9.4	Advantages and limitations of compact spinning	251
9.5	Applications of compact yarn on downstream processing	253
9.6	Future trends	254
9.7	Sources of further information and advice	258
9.8	References	259
10	Rotor spinning	261
	A. DAS and R. ALAGIRUSAMY, IIT Delhi, India	
10.1	Introduction	261
10.2	Key features and operating principles of rotor spinning systems	262
10.3	Fibre transfer	265
10.4	Modern rotor spinning machines	269
10.5	Rotor spinning performance: yarn breakage	270
10.6	Structure and properties of rotor spun yarns	271
10.7	Conclusions	272
10.8	References	273
11	Friction spinning	274
	A. A. MERATI, Amirkabir University of Technology, Iran	
11.1	Introduction	274
11.2	Yarn formation on friction-spinning machines	277
11.3	Composite yarn spinning on friction spinning	286
11.4	Types of fibres used	289
11.5	Friction-spun yarn structure and properties	291
11.6	Advantages and limitations of friction spinning	306
11.7	Application of friction-spun yarns	308
11.8	Future trends	309
11.9	References and bibliography	310
12	Air-jet spinning	315
	R. A. ANGELOVA, Technical University of Sofia, Bulgaria	
12.1	Introduction	315
12.2	Basic air-jet spinning methods	318
12.3	Types of fibres used	324
12.4	Fasciated structure of air-jet spun yarns	326
12.5	The basic principles of the twisting mechanism by swirl flow	331
12.6	Simulation of the flow–yarn interaction	337
12.7	Properties of air-jet spun yarns	339
12.8	Advantages and limitations of air-jet spinning	340

12.9	Applications of air-jet spun yarns	341
12.10	Future trends	342
12.11	References	342
13	Hollow spindle spinning R. A. ANGELOVA, Technical University of Sofia, Bulgaria	345
13.1	Introduction	345
13.2	Basic principle of hollow spindle spinning	346
13.3	Structure of yarns made by hollow spindle machines	352
13.4	Assessment of the quality of wrap yarns	355
13.5	Application of hollow spindle spun yarns	358
13.6	Advantages and limitations of hollow spindle spinning	359
13.7	Future trends	361
13.8	References	362
14	Self-twist spinning M. R. MAHMOUDI, University of Leeds, UK	365
14.1	Introduction	365
14.2	Self-twist spinning: principles	368
14.3	Self-twist spinning technology	369
14.4	Factors affecting strand twist	376
14.5	Self-twist yarn strength and stability	381
14.6	References and sources of further information	387
15	Minimizing fiber damage caused by spinning Y. ELMOGAHZY and R. FARAG, Auburn University, USA	390
15.1	Introduction	390
15.2	Textile fiber characteristics and processing	391
15.3	Fiber breakage	393
15.4	Fiber damage in the yarn-forming process	402
15.5	Fiber damage in ring and compact spinning	402
15.6	Fiber damage in rotor spinning	408
15.7	Fiber damage in friction spinning	409
15.8	Conclusion	412
15.9	References	414
16	Spin finishes for textiles I. A. ELHAWARY, Alexandria University, Egypt	416
16.1	Introduction	416
16.2	Components of spin finishes	417
16.3	Types and application of spin finishes	418
16.4	Key requirements for spin finishes	420

x	Contents	
16.5	Quality issues in the use of spin finishes	422
16.6	Use of spin finishes on particular types of fibre	423
16.7	Use of spin finishes with particular spinning systems	425
16.8	Testing spin finishes	427
16.9	Sources of further information and advice	429
16.10	Acknowledgement	429
16.11	References	429
	<i>Index</i>	431

## Contributor contact details

---

(\* = main contact)

### Editor and Chapter 1

C. A. Lawrence  
Centre for Technical Textiles  
School of Design  
University of Leeds  
Leeds LS2 9JT  
UK

E-mail: c.a.lawrence@leeds.ac.uk

### Chapters 4 and 14

M. R. Mahmoudi  
School of Design  
University of Leeds  
Woodhouse Lane  
Leeds LS2 9JT  
UK

E-mail: m.r.mahmoudi@leeds.ac.uk

### Chapters 2 and 7

R. S. Rengasamy  
Department of Textile Technology  
Indian Institute of Technology  
New Delhi-110016  
India

E-mail: rsrengasamy@gmail.com

### Chapter 5

Professor G. K. Tyagi  
The Technological Institute of  
Textile and Sciences  
Bhiwani 127 021  
India

E-mail: drgktyagi@yahoo.com

### Chapters 3 and 10

Associate Professor A. Das\* and  
Professor R. Alagirusamy  
Department of Textile Technology  
IIT Delhi  
Hauz Khas  
New Delhi-110016  
India

E-mail: apurba65@gmail.com

### Chapter 6

Professor H. M. Behery  
Clemson University  
229 Camelot Road  
Clemson  
SC 29631-2103  
USA

E-mail: hassanbehery@yahoo.com

## Chapter 8

P. R. Lamb\* and Professor X.  
Wang  
Centre for Material and Fibre  
Innovation  
Waurm Ponds Campus  
Deakin University  
Geelong  
Victoria 3217  
Australia

E-mail: peter.lamb@deakin.edu.au  
xungai.wang@deakin.edu.au

## Chapter 9

Professor M. A. M. El-Sayed\* and  
Associate Professor S. H. Sanad  
Spinning Research Department  
Cotton Research Institute  
Agricultural Research Centre  
9 Gamaa St.  
12619-Giza  
Egypt

E-mail: negmmohamed@yahoo.com

## Chapter 11

Assistant Professor A. A. Merati  
Advanced Textile Materials and  
Technology Research Institute  
Amirkabir University of  
Technology  
424, Hafez Ave.  
P.O. Box 15875-4413  
Tehran  
Iran

E-mail: merati@aut.ac.ir

## Chapters 12 and 13

Professor R. A. Angelova  
Department of Textiles  
Technical University of Sofia  
8 Kl. Ochriski blvd  
Sofia 1756  
Bulgaria

E-mail: radost@tu-sofia.bg

## Chapter 15

Y. Elmogahzy and R. Farag  
Polymer and Fiber Engineering  
101 Textile Building  
Auburn University  
Auburn, AL 36849  
USA

E-mail: elmogye@auburn.edu

## Chapter 16

Professor I. A. Elhawary  
Textile Engineering Department  
Faculty of Engineering  
Alexandria University  
Alexandria 21544  
Egypt

E-mail: hawary\_45@yahoo.com

## Woodhead Publishing Series in Textiles

---

- 1 **Watson's textile design and colour Seventh edition**  
*Edited by Z. Grosicki*
- 2 **Watson's advanced textile design**  
*Edited by Z. Grosicki*
- 3 **Weaving Second edition**  
*P. R. Lord and M. H. Mohamed*
- 4 **Handbook of textile fibres Vol 1: Natural fibres**  
*J. Gordon Cook*
- 5 **Handbook of textile fibres Vol 2: Man-made fibres**  
*J. Gordon Cook*
- 6 **Recycling textile and plastic waste**  
*Edited by A. R. Horrocks*
- 7 **New fibers Second edition**  
*T. Hongu and G. O. Phillips*
- 8 **Atlas of fibre fracture and damage to textiles Second edition**  
*J. W. S. Hearle, B. Lomas and W. D. Cooke*
- 9 **Ecotextile '98**  
*Edited by A. R. Horrocks*
- 10 **Physical testing of textiles**  
*B. P. Saville*
- 11 **Geometric symmetry in patterns and tilings**  
*C. E. Horne*
- 12 **Handbook of technical textiles**  
*Edited by A. R. Horrocks and S. C. Anand*
- 13 **Textiles in automotive engineering**  
*W. Fung and J. M. Hardcastle*
- 14 **Handbook of textile design**  
*J. Wilson*
- 15 **High-performance fibres**  
*Edited by J. W. S. Hearle*
- 16 **Knitting technology Third edition**  
*D. J. Spencer*

- 17 **Medical textiles**  
*Edited by S. C. Anand*
- 18 **Regenerated cellulose fibres**  
*Edited by C. Woodings*
- 19 **Silk, mohair, cashmere and other luxury fibres**  
*Edited by R. R. Franck*
- 20 **Smart fibres, fabrics and clothing**  
*Edited by X. M. Tao*
- 21 **Yarn texturing technology**  
*J. W. S. Hearle, L. Hollick and D. K. Wilson*
- 22 **Encyclopedia of textile finishing**  
*H-K. Rouette*
- 23 **Coated and laminated textiles**  
*W. Fung*
- 24 **Fancy yarns**  
*R. H. Gong and R. M. Wright*
- 25 **Wool: Science and technology**  
*Edited by W. S. Simpson and G. Crawshaw*
- 26 **Dictionary of textile finishing**  
*H-K. Rouette*
- 27 **Environmental impact of textiles**  
*K. Slater*
- 28 **Handbook of yarn production**  
*P. R. Lord*
- 29 **Textile processing with enzymes**  
*Edited by A. Cavaco-Paulo and G. Gübitz*
- 30 **The China and Hong Kong denim industry**  
*Y. Li, L. Yao and K. W. Yeung*
- 31 **The World Trade Organization and international denim trading**  
*Y. Li, Y. Shen, L. Yao and E. Newton*
- 32 **Chemical finishing of textiles**  
*W. D. Schindler and P. J. Hauser*
- 33 **Clothing appearance and fit**  
*J. Fan, W. Yu and L. Hunter*
- 34 **Handbook of fibre rope technology**  
*H. A. McKenna, J. W. S. Hearle and N. O'Hear*
- 35 **Structure and mechanics of woven fabrics**  
*J. Hu*
- 36 **Synthetic fibres: nylon, polyester, acrylic, polyolefin**  
*Edited by J. E. McIntyre*
- 37 **Woollen and worsted woven fabric design**  
*E. G. Gilligan*
- 38 **Analytical electrochemistry in textiles**  
*P. Westbroek, G. Priniotakis and P. Kiekens*

- 39 **Bast and other plant fibres**  
*R. R. Franck*
- 40 **Chemical testing of textiles**  
*Edited by Q. Fan*
- 41 **Design and manufacture of textile composites**  
*Edited by A. C. Long*
- 42 **Effect of mechanical and physical properties on fabric hand**  
*Edited by Hassan M. Behery*
- 43 **New millennium fibers**  
*T. Hongu, M. Takigami and G. O. Phillips*
- 44 **Textiles for protection**  
*Edited by R. A. Scott*
- 45 **Textiles in sport**  
*Edited by R. Shishoo*
- 46 **Wearable electronics and photonics**  
*Edited by X. M. Tao*
- 47 **Biodegradable and sustainable fibres**  
*Edited by R. S. Blackburn*
- 48 **Medical textiles and biomaterials for healthcare**  
*Edited by S. C. Anand, M. Mirafteb, S. Rajendran and J. F. Kennedy*
- 49 **Total colour management in textiles**  
*Edited by J. Xin*
- 50 **Recycling in textiles**  
*Edited by Y. Wang*
- 51 **Clothing biosensory engineering**  
*Y. Li and A. S. W. Wong*
- 52 **Biomechanical engineering of textiles and clothing**  
*Edited by Y. Li and D. X-Q. Dai*
- 53 **Digital printing of textiles**  
*Edited by H. Ujiie*
- 54 **Intelligent textiles and clothing**  
*Edited by H. Mattila*
- 55 **Innovation and technology of women's intimate apparel**  
*W. Yu, J. Fan, S. C. Harlock and S. P. Ng*
- 56 **Thermal and moisture transport in fibrous materials**  
*Edited by N. Pan and P. Gibson*
- 57 **Geosynthetics in civil engineering**  
*Edited by R. W. Sarsby*
- 58 **Handbook of nonwovens**  
*Edited by S. Russell*
- 59 **Cotton: Science and technology**  
*Edited by S. Gordon and Y-L. Hsieh*
- 60 **Ecotextiles**  
*Edited by M. Mirafteb and A. R. Horrocks*

- 61 **Composite forming technologies**  
*Edited by A. C. Long*
- 62 **Plasma technology for textiles**  
*Edited by R. Shishoo*
- 63 **Smart textiles for medicine and healthcare**  
*Edited by L. Van Langenhove*
- 64 **Sizing in clothing**  
*Edited by S. Ashdown*
- 65 **Shape memory polymers and textiles**  
*J. Hu*
- 66 **Environmental aspects of textile dyeing**  
*Edited by R. Christie*
- 67 **Nanofibers and nanotechnology in textiles**  
*Edited by P. Brown and K. Stevens*
- 68 **Physical properties of textile fibres Fourth edition**  
*W. E. Morton and J. W. S. Hearle*
- 69 **Advances in apparel production**  
*Edited by C. Fairhurst*
- 70 **Advances in fire retardant materials**  
*Edited by A. R. Horrocks and D. Price*
- 71 **Polyesters and polyamides**  
*Edited by B. L. Deopura, R. Alagirusamy, M. Joshi and B. S. Gupta*
- 72 **Advances in wool technology**  
*Edited by N. A. G. Johnson and I. Russell*
- 73 **Military textiles**  
*Edited by E. Wilusz*
- 74 **3D fibrous assemblies: Properties, applications and modelling of three-dimensional textile structures**  
*J. Hu*
- 75 **Medical textiles 2007**  
*Edited by J. F. Kennedy, S. C. Anand, M. Mirafteb and S. Rajendran*
- 76 **Fabric testing**  
*Edited by J. Hu*
- 77 **Biologically inspired textiles**  
*Edited by A. Abbott and M. Ellison*
- 78 **Friction in textile materials**  
*Edited by B. S. Gupta*
- 79 **Textile advances in the automotive industry**  
*Edited by R. Shishoo*
- 80 **Structure and mechanics of textile fibre assemblies**  
*Edited by P. Schwartz*
- 81 **Engineering textiles: Integrating the design and manufacture of textile products**  
*Edited by Y.E. El-Mogahzy*

- 82 **Polyolefin fibres: industrial and medical applications**  
*Edited by S. C. O. Ugbolue*
- 83 **Smart clothes and wearable technology**  
*Edited by J. McCann and D. Bryson*
- 84 **Identification of textile fibres**  
*Edited by M. Houck*
- 85 **Advanced textiles for wound care**  
*Edited by S. Rajendran*
- 86 **Fatigue failure of textile fibres**  
*Edited by M. MirafTAB*
- 87 **Advances in carpet technology**  
*Edited by K. Goswami*
- 88 **Handbook of textile fibre structure Volume 1 and Volume 2**  
*Edited by S. J. Eichhorn, J.W.S. Hearle, M. Jaffe and T. Kikutani*
- 89 **Advances in knitting technology**  
*Edited by K-F. Au*
- 90 **Smart textile coatings and laminates**  
*Edited by W. C. Smith*
- 91 **Handbook of tensile properties of textile and technical fibres**  
*Edited by A. R. Bunsell*
- 92 **Interior textiles: Design and developments**  
*Edited by T. Rowe*
- 93 **Textiles for cold weather apparel**  
*Edited by J. T. Williams*
- 94 **Modelling and predicting textile behaviour**  
*Edited by X. Chen*
- 95 **Textiles, polymers and composites for buildings**  
*Edited by G. Pohl*
- 96 **Engineering apparel fabrics and garments**  
*J. Fan and L. Hunter*
- 97 **Surface modification of textiles**  
*Edited by Q. Wei*
- 98 **Sustainable textiles**  
*Edited by R. S. Blackburn*
- 99 **Advances in yarn spinning technology**  
*Edited by C. A. Lawrence*
- 100 **Handbook of medical textiles**  
*Edited by V. T. Bartels*
- 101 **Technical textile yarns**  
*Edited by R. Alagirusamy and A. Das*
- 102 **Applications of nonwovens in technical textiles**  
*Edited by R. A. Chapman*
- 103 **Colour measurement: Principles, advances and industrial applications**  
*Edited by M. L. Gulrajani*

- 104 **Textiles for civil engineering**  
*Edited by R. Figueiro*
- 105 **New product development in textiles**  
*Edited by B. Mills*
- 106 **Improving comfort in clothing**  
*Edited by G. Song*
- 107 **Textile biotechnology**  
*Edited by V. Nierstrasz*
- 108 **Textiles for hygiene**  
*Edited by B. McCarthy*
- 109 **Nanofunctional textiles**  
*Edited by Y. Li*
- 110 **Joining textiles**  
*Edited by I. Jones and G. Stylios*
- 111 **Soft computing in textile engineering**  
*Edited by A. Majumdar*
- 112 **Textile design**  
*Edited by A. Briggs-Goode and K. Townsend*
- 113 **Biotextiles as medical implants**  
*Edited by M. King and B. Gupta*
- 114 **Textile thermal bioengineering**  
*Edited by Y. Li*
- 115 **Woven textile structure**  
*B. K. Behera and P. K. Hari*
- 116 **Handbook of textile and industrial dyeing Volume 1: Principles processes and types of dyes**  
*Edited by M. Clark*
- 117 **Handbook of textile and industrial dyeing Volume 2: Applications of dyes**  
*Edited by M. Clark*
- 118 **Handbook of natural fibres Volume 1: Types, properties and factors affecting breeding and cultivation**  
*Edited by R. Kozłowski*
- 119 **Handbook of natural fibres Volume 2: Processing and applications**  
*Edited by R. Kozłowski*
- 120 **Functional textiles for improved performance, protection and health**  
*Edited by N. Pan and G. Sun*
- 121 **Computer technology for textiles and apparel**  
*Edited by Jinlian Hu*
- 122 **Advances in military textiles and personal equipment**  
*Edited by E. Sparks*
- 123 **Specialist yarn, woven and fabric structure: Developments and applications**  
*Edited by R. H. Gong*

# Part I

## Introduction to yarn spinning and structure



# Overview of developments in yarn spinning technology

---

C. A. LAWRENCE, University of Leeds, UK

**Abstract:** An historical account is given of the development of the yarn spinning process, from its initial beginnings as a hand craft, to the mechanisation of the process during the Industrial Revolution, and through into the twentieth century when a wide range of different spinning techniques were developed. The basic equations generally applicable to spinning technology are presented and descriptions given of the various techniques currently used commercially, classified according to the fundamental principles of the method on which they are based.

**Key words:** staple-spun yarn, drop spindle, distaff, spinning wheel, spinning jenny, saxon wheel, water frame, spinning mule, ring spinning, open-end spinning, self-twist, wrap spinning.

## 1.1 Introduction

The term ‘spinning’ may be defined [1] as the process or processes used to

- produce either fibres or filaments from natural or synthetic polymers, or
- convert natural or man-made fibres (mmf) and filaments into yarns by twisting or other means of binding together the fibres or filaments. This provides a relatively fine continuous length of thread that has properties suitable for conversion into a fabric form or for use directly for sewing or rope making.

The spinning processes employed to make fibres or filaments may be generally classed as polymer extrusion methods. Typical extrusion processes are melt-spinning, wet-spinning and dry-spinning; there are also variants of these [2, 3]. For melt-spinning, a thermoplastic polymer, such as polyester, polypropylene or nylon, is in principle heated to a molten state and pumped through precision-machined holes in a metal plate, referred to as a spinneret; the issuing molten streams are then cooled to form a group of up to, say, 1000 filaments or a tow of 300,000 filaments; the latter is subsequently cut into staple fibres. Polymers that are thermally difficult to melt-spin may

be dissolved in a suitable solvent to produce a viscous liquid or dope. In wet-spinning the dope is extruded into a bath containing a liquid coagulant, which enables polymer streams to congeal into filaments or subsequently to be converted to staple fibres. With dry-spinning the dope is extruded into heated gas, which facilitates evaporation of the solvent from the molten stream to form the filaments. Each extrusion method has specific technological and commercial advantages, the discussion of which is outside the scope of this book. The focus of this book is on a subsection of the second category of the spinning definition, called staple-fibre spinning. The twisting, or processing by other means, of filaments into yarns therefore will not be discussed and the reader may wish to refer to the cited literature [4–6] for information on the technology involved in filament yarn production.

It can be reasoned from the short description above of staple-fibre production that staple-fibre spinning is concerned with the means of consolidating a collection of discrete lengths of thin natural or man-made polymer materials into a yarn. Such a yarn would be called a staple-spun yarn or spun-staple yarn, and therefore may be defined as follows:

*A staple-spun yarn is a linear assembly of many fibres in the cross-section and along the length, held together usually by the insertion of twist to form a continuous strand, small in diameter but of any specified length. It is used for interlacing in processes such as knitting, weaving and sewing.*  
[1]

Before presenting an overview of the various staple-fibre spinning processes, it is useful to give a short explanation of the concept ‘staple fibres’. It was explained earlier that an extruded tow of filaments can be cut or broken into discrete lengths to produce staple fibres. Staple-fibre spinning systems, however, were originally developed for converting natural fibres into spun yarns and therefore tows are generally cut to give similar length characteristics, particularly when a yarn blend of natural and mmf is to be spun. The filaments are often extruded to correspond to the fineness of the natural fibres. In the commercial production of staple-spun yarns from natural fibres it is essential that certain of the fibre properties are known, in particular the length characteristics, fibre fineness, colour and cleanliness. Natural fibres are therefore sold by grades based on these measured properties. A detailed account of the importance of these properties in yarn production is given elsewhere in the published literature [7–10].

## 1.2 Early history

### 1.2.1 Hand spinning

Historically, staple-fibre spinning is an ancient craft. Although the precise date of its origin has yet to be known, there is archaeological evidence of

'string skirts' dating back around 20,000 years ago, to Paleolithic times [11]. The early skill of spinning a thread from staple fibres, however, is believed to have been in existence at least some 8000 to 10,000 years ago. The weaving of yarns can be dated back to Neolithic times, around 6000 BC, and both skills are said to predate pottery, which can be traced to around 5000 BC. It is likely that one of the earliest fibres to be spun was wool, since sheep existed about 1 million years ago during the early Pleistocene period. The domestication of sheep can be traced back to 9000 BC. in northern Iraq at Zam Chem Shanidar.

The early spinning technique seems likely to have been accomplished without the use of tools, by stretching out a thin bunch of fibres with one hand (the attenuating action being referred to as drawing) while twisting together the fibres of the attenuated length between the fingers of the other hand. To gain more twist the yarn would then be fastened to a stone – called a whorl – which was twirled by hand and allowed to drop vertically, thereby generating the twisting torque. With the yarn now aligned with the axis of rotation, the torque inserts the twist into it. This may be classed as 'on-axis twisting'.

It is also possible that the first stage of the twisting process was more easily achieved by rolling the attenuated length between the outside of the spinner's thigh and the palm of the hand used to insert the twist: see Fig. 1.1 [11]. It is not difficult to appreciate then that the latter technique would have been developed whereby a long straight stick of wood, a twig say, was rolled between the thigh and palm, with the attenuated length attached to the upper end of the stick. The use of such a stick would also enable the spinner to subsequently wind a spun length around the lower part of the

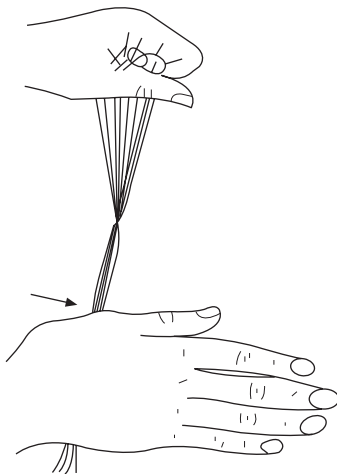

1.1 Early hand spinning technique (adapted from [11]).

stick and attach and twist another length to it. The concept of the spindle had therefore emerged. It wouldn't have taken much imagination to later attach the stone whorl to the stick spindle and in so doing shorten the spinning process by inventing what has become known as the drop spindle. Archaeological excavations in various regions of the world have uncovered many spindle whorls made of stone, some dating as far back as the Neolithic period [12, 13]. However, drop spindles can have whorls made of discs of wood, stone, clay and even metal with a hole in the centre for fitting the wooden spindle.

Along with the development of the twisting device an improvement in the handling of the fibre mass during the stretching out for twisting was needed. This led to an accompanying hand tool for the drop spindle called the distaff. Basically, this is a short stick around which the prepared fibrous mass would be wrapped. The fibre mass had first to be cleaned, disentangled and loosely consolidated into a continuous rope form. This would then be wound loosely around the top end of the distaff, while the other end was held under the spinner's arm, leaving the hands free for stretching out, i.e. drawing, and twisting the fibre mass [14]: see Fig. 1.2.

The drop spindle and distaff system was the principal spinning method for many thousands of years. It was a very versatile system since it could be used to spin various natural fibres of differing staple lengths such as cotton, wool, linen and flax. In addition coarse yarns could be made for ropes, as well as much finer threads for clothing, tapestries, sails for boats and the linen bandages in which Egyptian mummies were wrapped for burials (mummywraps). The process was of course labour intensive and very slow.

### 1.2.2 The spinning wheel

Although a precise date has yet to be determined, it is believed that it was within the geographical region of either India, China or Persia (now Iran)

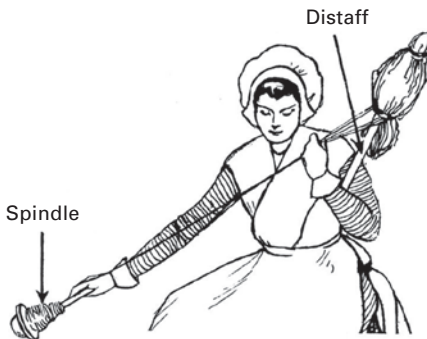

1.2 The drop spindle and distaff system (adapted from [14]).

linked to the Eastern wool, cotton and silk trade, during the period 500–1000 AD, that the spinning wheel was invented [12]. With this system the spindle is switched from vertical rotation and secured to rotate in the horizontal position. The whorl is replaced by a pulley wheel, which effectively is a thick whorl with a groove cut into its peripheral surface. To rotate this pulley, a larger pulley wheel – eventually just called the wheel – is positioned at a convenient distance from it and with both peripheral grooves lined up, a rope belt links the circumferences of the two pulleys. The spinner rotates the larger pulley, which drives the spindle-pulley via the movement of the rope belt. The direction in which the spinner rotates the wheel effects the same rotational direction of the spindle-pulley, see Fig. 1.3. Since one hand is needed to rotate the wheel, the way in which the yarn is then held as the fibre mass is being drafted and twisted had to be changed; suspending or tensioning the yarn on the spindle axis would be impractical from an ergonomic viewpoint. With an initial length of yarn (i.e. a seed yarn) already wound onto the top section of the spindle, a short part of the seed yarn is pulled over the tip of the spindle and held at an acute angle to the spindle axis. Rotating the spindle then causes a further portion of the seed yarn to spiral up the spindle length to the tip, after which each revolution causes one coil of spiral to slip off the tip, adding one turn of twist to that already in the seed yarn. As the prepared fibre mass would be attached to the end of the seed yarn, the twist propagating along the yarn gets inserted into the fibres as the mass is simultaneously drafted by hand. Winding the spun yarn onto the spindle is then achieved by holding the yarn perpendicularly to the spindle axis.

The spinning wheel retained its basic features for many centuries, with some variation in size of the larger wheel to gain a better gearing ratio for

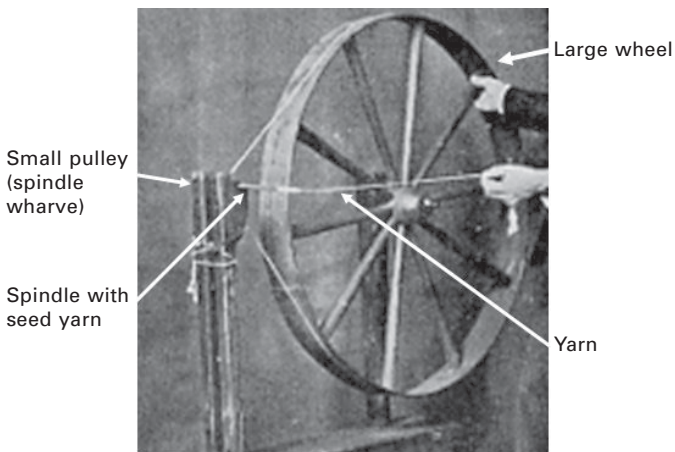

1.3 The spinning wheel (adapted from [15]).

faster spindle speeds, and although no authentic spinning wheel has survived from medieval times it is believed that post-1450 the pedal was fitted for better operation, freeing both hands to improve the drafting for the spinning of finer yarn counts.

The freedom to draft with both hands led to improvements in preparing the fibre mass for spinning. An essential requirement was always to break up a large entangled mass of cleaned material into small sizes, termed tufts. This made it easier to disentangle, straighten and parallelise the fibres comprising the tufts and to mix or blend the fibres thoroughly together into a coherent mass, a process known as carding. At the time this would be done by hand and, for efficiency, one person would card the material in preparation for spinning while another would undertake the task of spinning the yarn: see Fig. 1.4.

Figure 1.5 illustrates a pair of hand cards and the carding process. Each hand card comprises a flat wooden board 40 cm long, 20 cm wide and 3 cm thick, one surface of which, the working surface, has wire bristles<sup>1</sup> projecting at an angle from it. Several fibre tufts would be held between the working surfaces of a pair of hand cards, held with the projecting bristles opposing, referred to as a point-to-point action<sup>2</sup> [15]. The repeated action then of sliding the surfaces past each other in opposing directions disentangles the fibres, and tends towards straightening and parallelising them. A web of fibres in

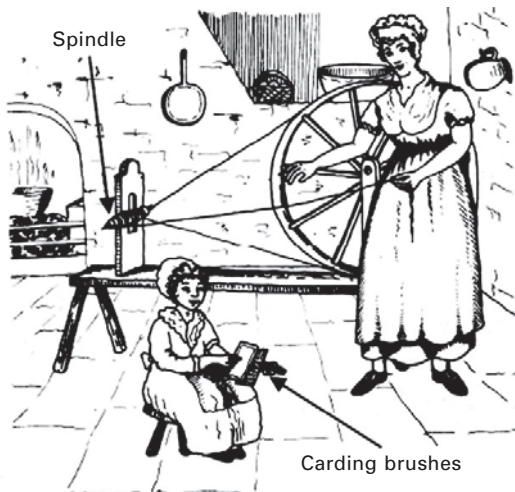

1.4 Cottage hand carding and spinning (adapted from [16]).

<sup>1</sup>Initially teazles were used.

<sup>2</sup>With carding machines where saw-tooth wires are used, the term is point-of-tooth to point-of-tooth.

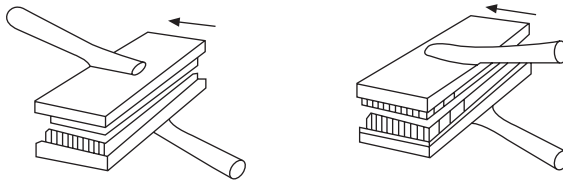

1.5 Hand carding actions (adapted from [15]).

this ‘opened’ state is formed, and removed from the bristles by the reverse sliding action, i.e. point-to-back; reciprocating the sliding action converts the web of fibres into a soft fleecy roll of fibre or card sliver. Spinning would be carried out in two stages. The first would be to slightly draft the sliver and insert a small amount of twist to produce a softly twisted strand called a roving. In the second stage the roving, having only a small amount of twist, would be further drafted and a much higher amount of twist inserted to make the yarn.

### 1.3 Early developments

#### 1.3.1 Hargreaves’ spinning jenny

The use of the spinning wheel for the two-stage yarn production process spread throughout Europe and was the method widely employed for producing cotton yarns and yarns from short wools up until 1764, when the demand for increased yarn production led to the invention of the ‘spinning jenny’ by James Hargreaves, a British weaver from the town of Blackburn in northern England. It is interesting that it was a weaver who effectively moved the spinning process towards an industrial scale. At the time, the growing demand for spun yarns was a result of another weaver’s invention – John Kay’s ‘flying shuttle’. This greatly increased the rate of woven cloth production on the handloom.

The spinning jenny [15], see Fig. 1.6, may be viewed as an upscale development of the spinning wheel, in that it was an ingenious way of attaining multiple-spindle spinning whereby, at that time, a single machine run by one operative could replace upwards of 25 spinning wheels<sup>3</sup>, reducing labour and production time as well as increasing production speed.

Figure 1.7 shows a simple diagram of its operation. The large wheel, B, driven by hand, drove a cylinder, A, of sizeable diameter and a length which spanned the width of the spinning frame. Each spindle-pulley was in turn driven via its own rope belt circumferentially linked to the cylinder. Two rows of spindles would be held within blind holes drilled in fixed

<sup>3</sup>Hargreaves’ first machine consisted of eight spindles.

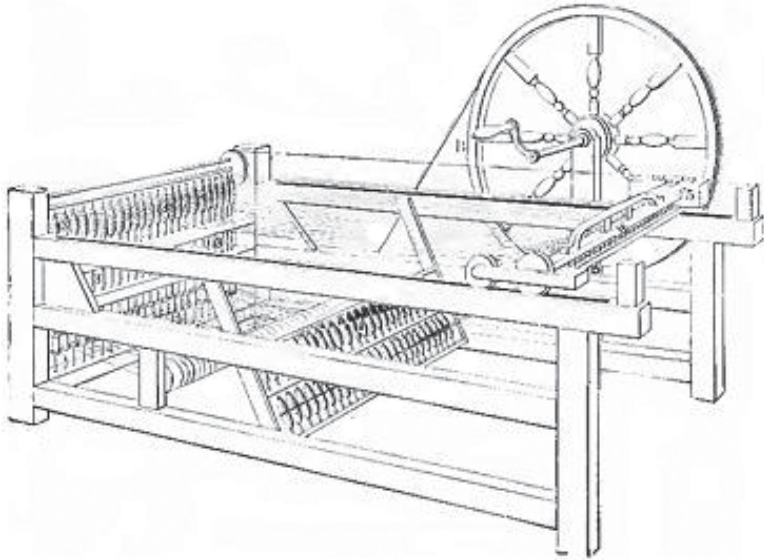

1.6 The spinning jenny (adapted from [17]).

wooden rails, but free to rotate on their axes. Because hand carding was still the practice, rovings had still to be prepared on the spinning wheel. The prepared rovings would be presented to the spinning jenny already wound onto spindles. Roving packages, F, would be mounted in a similar way to the yarn spindles, but now on moveable wooden rails fitted to a carriage. When a yarn length was made, a mechanism, J and G, would position the yarn length for winding onto the spindles. The roving carriage and a guide arrangement, C, D and E in the closed position, would then be moved towards the spindle, with say the left hand of the operative, at a suitable speed to enable the winding up of the yarns as the spindles are driven by rotating the large wheel by the right hand (Fig. 1.7(a)). The spindles would then be stopped and the guide arrangement opened and then pulled backwards to allow a new length of roving to be positioned for drafting (Fig. 1.7(b)). With the roving guide arrangement now closed, drafting is accomplished by pulling the carriage towards the backmost position while rotating the spindle to insert twist (Fig. 1.7(c)); the combined action is termed spindle drafting. Referring to the parts of Fig. 1.7, the ratio of the lengths in (a) to (c) and (a) to (b) gives the amount of attenuation or draft applied to the roving. Thus, the total spinning draft,  $D_T$ , can be calculated from the length of the roving guide positions:

$$D_T = L_2/L_1 \quad 1.1$$

where  $L_1$  is the length difference in the guide positions shown in Figs 1.7(a)

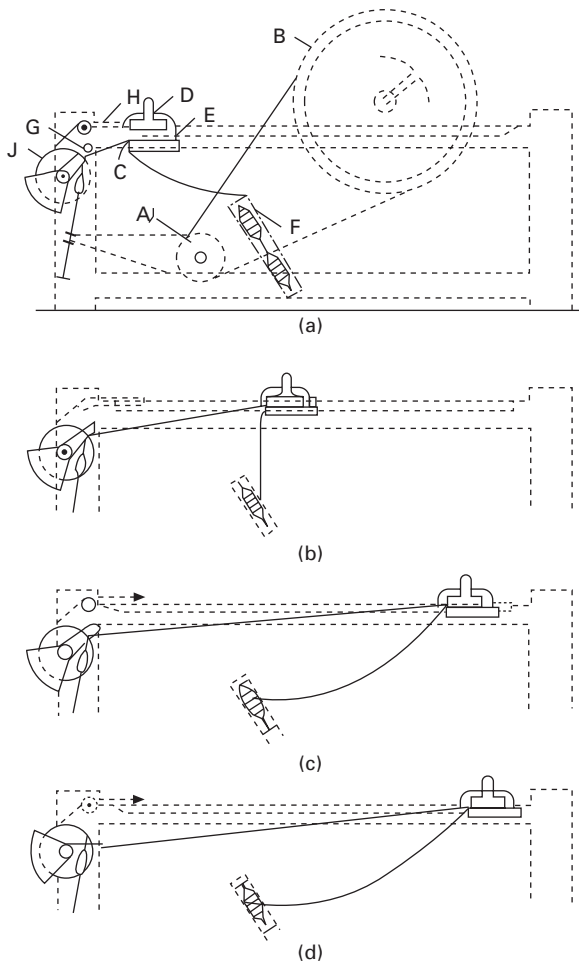

1.7 Operation of the spinning jenny (adapted from [15]).

and 1.7(b), and  $L_2$  is the length difference in the guide positions shown in Figs 1.7(a) and 1.7(c).

In position (c) the spindle rotation would continue until the required amount of twist is inserted. If the unit of length measurement is metres, then the final degree of twist,  $T$ , can be calculated as:

$$T = N/L_2 \text{ (unit: turns } m^{-1}\text{)} \quad 1.2$$

where  $N$  is the total number of spindle rotations.

With the roving guide in the position shown in Fig. 1.7(d), the mechanism J and G is adjusted to angle the newly formed yarn length for winding, the slight increase in length from (c) to (d) giving the winding tension, which

should be maintained as the guide is moved towards the spindle. On wind-up, the whole process is then repeated as many times as required until either all the roving is used or a sufficient length of yarn is wound onto the spindle. Each spindle with yarn, termed a cop, is then removed and new spindles are put into place, a process known as doffing. It should be noted here that although the spinning jenny was a major improvement on the simple system of the single spinning wheel, the spinning process was still intermittent, winding did not occur simultaneously with drafting and twisting.

### 1.3.2 The Saxon wheel

The spinning of long fibres, including flax and hemp, was somewhat more cumbersome on the simple spinning wheel, largely because long fibres are usually much coarser and therefore the yarns spun with them are also much coarser. Consequently, not only would drafting with one hand while turning the large wheel with the other be more difficult, but the amount of yarn that could be wound onto the spindle would be much smaller. The development which overcame these disadvantages, and also led to the concept of a continuous spinning process, was called the long-fibre wheel [15] or the Saxon wheel [18]. Although Leonardo da Vinci is said to have first depicted the concept on paper, it is Johan Jurgen, a wood-carver from Brunswick, who is claimed to have invented the system in 1530, after da Vinci's death in 1519. With this system a foot treadle was used to rotate the large wheel so that both hands could be used for drafting while twisting, and twisting and winding occurred as combined actions. Hence spinning could become continuous if the prepared fibre could be continuously attached to the yarn length being formed by twisting. The development of this latter requirement came later, so let us first consider the mechanism of combined twisting and winding on the Saxon wheel.

Figure 1.8 illustrates the spinning actions of the Saxon wheel. The innovative step was the use of a bobbin and flyer combination, both of which were mounted on the spindle. The spindle passed through the central axis of the bobbin with just sufficient clearance not to impart any rotation to the bobbin. The drive wheel has two grooves in its periphery and one is linked to the spindle wharve, A (a smaller grooved pulley wheel), by a looped cord passed around the two wheels. The bobbin, C, is fitted with its own wharve, D, smaller than that of the spindle wharve. Similar to the spindle, it is driven by the drive wheel using the second peripheral groove of the latter. Thus, if  $d_s$  and  $d_b$  are the respective diameters of spindle and bobbin wharves, and  $D_L$  is the diameter of the much larger drive wheel being rotated by foot treadle at  $N_L$  rpm, then

$$N_s = (D_L/d_s) N_L \quad 1.3$$

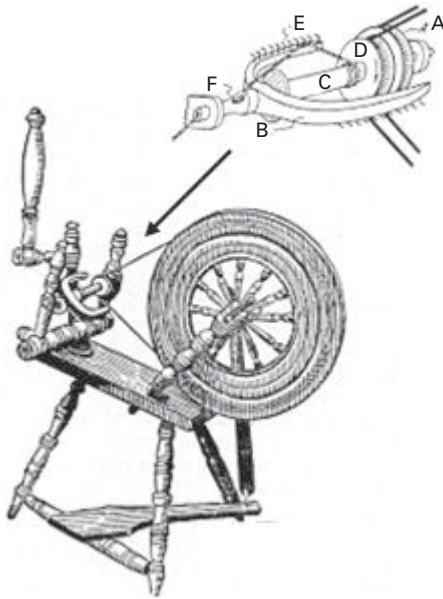

1.8 The Saxon wheel (adapted from [16]).

and

$$N_b = (D_L/d_b) N_L \tag{1.4}$$

which gives

$$N_b = N_s (d_s/d_b) \tag{1.5}$$

where  $N_s$  is the spindle rotational speed (r/min) and  $N_b$  is the bobbin rotational speed (r/min). So the rotational speed of the bobbin will be faster than that of the spindle by an amount equal to the ratio of their driven wharve diameters.

To insert twist and simultaneously wind onto the bobbin, the yarn being spun must first be angled to the spindle axis suitably for twisting and the earlier twisted part of the yarn length must simultaneously be angled at right angles to the co-axes of spindle and bobbin. To achieve this, the spindle has mounted on its top, above the bobbin, a component known as the flyer. This is fitted to rotate with the spindle. The flyer is shaped to have two legs or arms, B in Fig. 1.8, for balanced rotation and a hollow central shaft with a side hole, F. Each leg has a series of wire guides, E, and the gap between the legs governs the diameter to which the yarn can be built on the bobbin, and thereby the amount of yarn or the total continuous length that can be wound onto the bobbin. As Fig. 1.8 illustrates, the path of the yarn being twisted and wound up is down the hollow shaft, through the exit F around the appropriate wire guide, E (called a heck), that gives the required winding angle and then onto the bobbin. It should be clear that progressively moving

the yarn from one wire guide to another, starting at the one closest to the end of the flyer leg, facilitates winding along the full length of the bobbin.

Directly driving the bobbin presents the following problem. It is the surface speed that is of importance, initially of the bobbin, but then of the package being formed as the yarn layers build up onto the bobbin. The spinner has to hand draft at a rate which equals this speed. Each yarn layer wound onto the bobbin increases the surface speed of the package being formed. The package diameter has therefore to be limited, since there is a maximum speed at which the spinner could hand draft. Limiting the package diameter in turn limits the yarn length on a package for weaving; assuming the practical issues were resolved, increasing the package length would only give a small improvement in package size.

### 1.3.3 Arkwright's water frame

The first device for replacing the manual skill of hand drafting is attributable to Lewis Paul who obtained a patent in 1738 for the mechanism of roller drafting [19, 20]. Coupling the idea of roller drafting with the flyer and spindle combination, in 1769, five years after Hargreaves' spinning jenny, Richard Arkwright developed the first technically powered spinning machine, called the water frame [15]. It was initially meant to be man-powered and was then called the spinning frame, but being too large to operate by hand the use of horses was experimented with and subsequently discarded for the power of the water wheel. The two important advancements that the water frame contributed to spinning development were the application of roller drafting and a modification to the winding of yarns by a flyer-spindle device.

Figure 1.9 depicts the key features of Arkwright's water frame on a four spinning position machine or 'four spindle machine'. The roller drafting system is positioned above the flyer-spindle, in such a way that the angle of the forming yarn to the spindle axis during twisting on the spinning wheel is retained. Three metal rollers are used, having grooves (or flutes – fluted rollers) cut around the periphery of the parts of their lengths that perform the drafting. Three other rollers, with softer peripheral surfaces, possibly wooden rollers covered in leather, would be weighted down on the metal rollers. Such an arrangement can be termed a 3-over-3 drafting system or a 3-pair roller drafting system; the metal rollers would be the bottom rollers and the leather-covered ones the top rollers, a bottom roller and a top roller being a pair. To obtain good drafting and avoid breaking fibres, the roller pairs must be positioned a distance apart slightly longer than the staple length of the fibres being spun. The bottom rollers are the driven rollers and Fig. 1.10 illustrates how drafting occurs. The roving to be spun would be fed into the backmost roller pair; the middle roller pair would run slightly faster, while the front pair would operate much faster. As the leading ends of the fibres

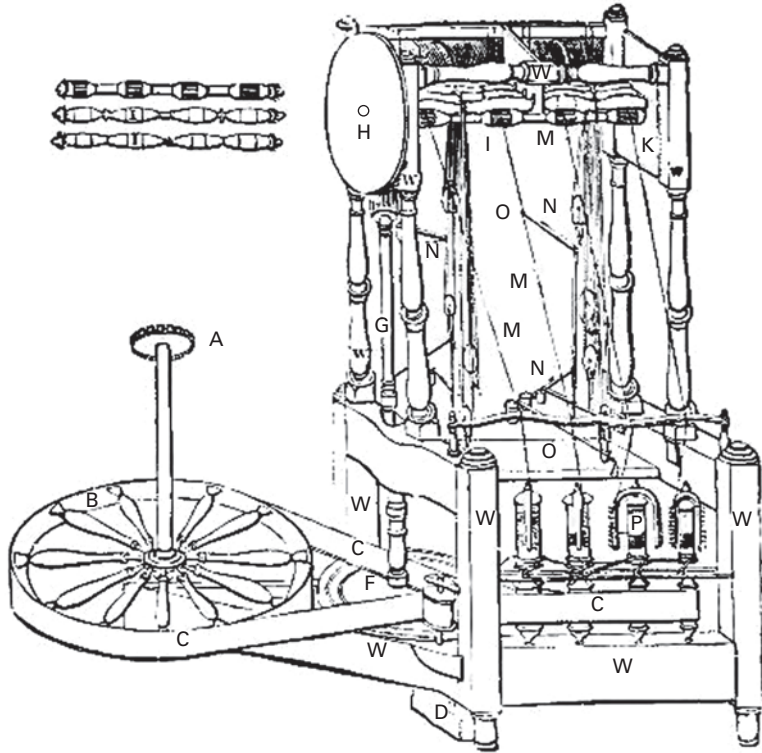

1.9 Richard Arkwright's water frame (adapted from [15]).

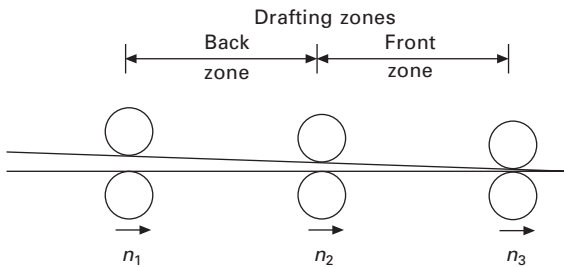

1.10 Basic roller drafting.

in the roving contact the nip-line of the middle roller pair, because of the positioning of the roller pairs, the trailing ends of these fibres are released, while others are still being nipped by the back roller pair. The middle roller pair therefore pulls forward the fibres they have nipped, feeding them towards the faster-moving front pair. This action gives an initial attenuation to the roving. The action, however, is repeated between the middle roller pair and the front roller pair, and with the latter having a much faster speed the roving

is fully attenuated to the amount required. Drafting, therefore, takes place in two zones: the back zone, formed by the back and middle roller pairs; and the front zone, formed by the middle and front roller pairs. It is of interest to consider how the drafts for these zones are determined and how they are combined to give the total draft required.

Earlier, the total draft,  $D_T$ , for the spinning jenny equation (1.1) was given as the ratio of two lengths – the drafted length to the original length. The same approach can be taken here, but the lengths have to be considered in terms of the rotational speeds of the roller pairs. Since the bottom rollers are the driven rollers, the weighted top rollers can rotate at the most only at the same speed as their corresponding bottom roller, so we need to consider only the bottom rollers. Working from the back to the front, let the diameters of these rollers be  $d_1$ ,  $d_2$  and  $d_3$  respectively, and their rotation speeds be  $n_1$ ,  $n_2$  and  $n_3$ . Then for the initial draft, the length being issued forward, per unit of time, by the back rollers will be the original length, given by:

$$L_1 = \mathbf{p} d_1 n_1 \quad 1.6$$

and that from the middle pair

$$L_2 = \mathbf{p} d_2 n_2 \quad 1.7$$

According to equation (1.1), the initial draft is

$$D_{\text{in}} = L_2/L_1 = (d_2 n_2)/(d_1 n_1) \quad 1.8$$

Similarly, if  $L_3$  is the length being issued by the front rollers, then the final draft is

$$D_{\text{fin}} = L_3/L_2 = (d_3 n_3)/(d_2 n_2) \quad 1.9$$

Also, the total draft must be

$$D_T = L_3/L_1 = (d_3 n_3)/(d_1 n_1) \quad 1.10$$

It can then be seen arithmetically that

$$D_T = D_{\text{in}} D_{\text{fin}} \quad 1.11$$

Generally the roller pairs are of the same diameters so just the ratios of the roller speeds can be used.

It should be noted that the low level of twist given to the roving, which is retained during hand spinning, is completely removed during roller drafting. A drafted ribbon of fibres therefore issues out of the front drafting rollers. To begin spinning, the tail of a yarn length (the seed yarn) that is already threaded through the flyer and wound onto the bobbin is placed between the nip of the front rollers, so that as the spindle rotates the twist inserted propagates to the front rollers thereby binding, or twisting, the issuing ribbon

of fibres onto the seed yarn end, progressively forming a new continuous yarn length that is wound onto the bobbin.

Clearly the front rollers will issue the ribbon of fibres at a fixed speed and this must be effectively the surface speed of winding the yarn up into a package; faster than this, the tension in the yarn will become too high and the yarn will break; slower and a poor winding action will prevent spinning. The problem was resolved by dispensing with the idea of driving the bobbin and using instead the drag of the bobbin on the yarn. Thus, as the flyer circulates the bobbin it wraps the yarn around it. If the winding tension becomes high, the bobbin will be turned and in so doing prevents the value of the tension from being reached at which the yarn breaks. Felt discs may be placed under the bobbin to adjust the drag as required.

Besides the matter of calculating initial and final drafts, it was necessary to obtain a way of relating the degree of twist required in the yarn with the continuous running of the drafted ribbon issuing from the front rollers. Again, the simple length approach can be used. If we consider a unit length of 1 m of drafted ribbon and insert 100 turns of twist into it, the degree of twist would be 100 turns per metre ( $100 \text{ t m}^{-1}$ ). If it takes 1 min for the front rollers to issue 1 m of drafted ribbon, then to obtain the  $100 \text{ t m}^{-1}$  the spindle must revolve at 100 revolutions per minute ( $100 \text{ r min}^{-1}$ ). Hence, algebraically the twist inserted by the system would be given by

$$T = N_s/v_{fs} \quad 1.12$$

$$v_{fs} = \mathbf{p} d_3 n_3$$

where  $v_{fs}$  is the bottom front roller speed (units:  $\text{m min}^{-1}$ ),  $d_3$  and  $n_3$  are the roller diameter and rotation speed (units: m and  $\text{r min}^{-1}$ , respectively) and  $N_s$  is the spindle speed (units:  $\text{r min}^{-1}$ ).

Knowing the various rotation speeds that are required, appropriate pulleys and gears could then be fitted to the machine and driven by a large wheel, as shown in Fig. 1.9, which in turn is geared to the water wheel. Interestingly, a looped belt is used to drive the spindles by the large wheel, thereby enabling identical spindle speeds.

It can be seen from the above account that the start of mechanised multiple spindle spinning, or what may be termed industrialised spinning systems, transformed spinning from the craft to the technology stage. Thus, technical specifications had to be developed. Importantly, it is necessary to specify the mass per unit length of a yarn, and the term yarn count came into existence. Inconveniently, a wide range of unit lengths were developed and used over the years based on the imperial and metric units of the yard and the metre, respectively [21]. Table 1.1 lists several examples, and the reader may wish to refer to The Textile Institute's publication *Textile Terms and Definitions* for further examples [1].

Table 1.1 Yarn count system

Unit of count	Symbol	Abbreviation for unit	Standard mass unit	Standard length unit
Tex	$T_t$	tex	gram	1 km
Cotton count (English)	$N_{ec}$	cc (cotton count)	1 lb	840 yds (1 hank)
Cotton count (metric)	$N_m$		1 kg	1 km
Worsted (English)	$N_{ew}$		1 lb	360 yds (1 skein)
Woollen (English)	$N_y$		1 lb	256 yds (1 skein)

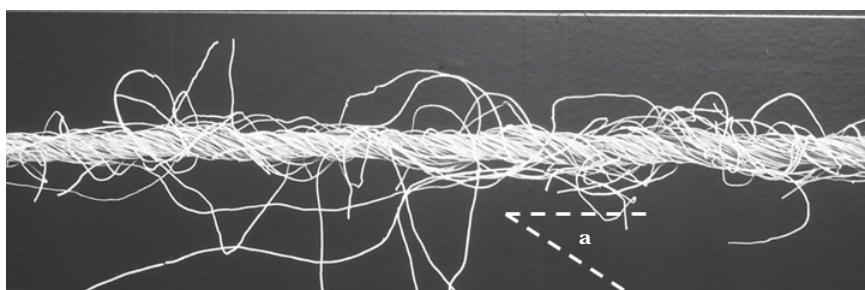

1.11 Surface twist angle.

An interesting technical point arises of how the twist inserted in a yarn is related to the yarn count. Figure 1.11 shows the surface twist angle of staple spun yarn. If this angle is  $\alpha$  then

$$\tan\alpha = \mathbf{p}d_yT \tag{1.13}$$

where  $d_y$  is the yarn diameter. The count of a yarn, in S.I. units, is related to its diameter according to:

$$C_y = 1000\mathbf{p}d_y^2/4\delta_y \tag{1.14}$$

where  $\delta_y$  is the specific volume in units of  $\text{g m}^{-1}$ . Thus, substituting in equation (1.13) for  $d_y$ :

$$\text{TM} = TC_y^{1/2} \tag{1.15}$$

$$\text{TM} = \tan\alpha/(4\mathbf{p}\delta_y/1000)^{1/2} \tag{1.16}$$

TM is referred to as the twist multiple or twist factor (TF). The reader is again referred to the publication *Textile Terms and Definitions* for further information in respect to the imperial and metric count systems.

### 1.3.4 Crompton's spinning mule

Following the development of the water frame, Samuel Crompton in 1779 invented the spinning mule, so called because it was a combination of the spinning jenny and the water frame. The principle of the spindle-drafting action was retained from the spinning jenny but the positions of the roving feed and rotating spindles were interchanged. Spindle-drafting was now obtained by the movement of the carriage housing the rotating spindles. The roving packages were mounted onto a creel and the rovings fed by rollers into the drafting zone (see Fig. 1.12), and the machine was powered by the mechanical means of the day.

The mule spinning process enabled large-scale manufacture of fine and coarse yarns, as a single operator could tend up to 1000 spindles. In the 1830s the 'self-acting' mule was developed. It was called 'self-acting' because it provided a mechanical means for automating the carriage movements (spindle-drafting and winding), and synchronising them with the roving feed by the rollers. Mules, each with 1320 spindles, became widely used for spinning fine yarns from cotton and wool. The mule yarn was a fine, strong but soft yarn which could be used to produce all kinds of fabrics. The versatility of mule yarns made this method of spinning the most common from 1790 until about 1900; the process is still used today to produce fine yarns from speciality fibres such as cashmere, mohair, alpaca, angora, etc.

As Fig. 1.12 indicates, roving packages or bobbins were creeled at the back of the spinning machine. At the start of this historical account it was explained that a roving would be made from a carded sliver; the sliver is drafted and a low twist inserted to form the roving. Although the flyer and bobbin combination was used for spinning, it became more popularly used as a roving production frame. The heck method of guiding the twisted length onto the bobbin was ultimately superseded by a mechanical system which involved a controlled direct drive to the bobbins to maintain a constant surface speed and an automatic traversing of the roving up and down the bobbin length [15].

The card slivers fed to each drafting position at the roving frame had to be of continuous length, which hand carding could not provide. The cottage hand card was developed into a simple drum card, which consisted of a large drum covered with wire points, above the surface of which were several other smaller drums covered with wire points angled in the opposite direction to those on the main drum. The smaller drums could be replaced by a series of fixed or moving plates (termed flats) having the angled projecting wire points. The former arrangement was best for long fibres and the latter for shorter fibres. These covered surfaces worked against each other in a similar way to the hand cards, i.e. the point-of-tooth to point-of-tooth carding action. A further drum (called the doffer), also having its peripheral surface covered

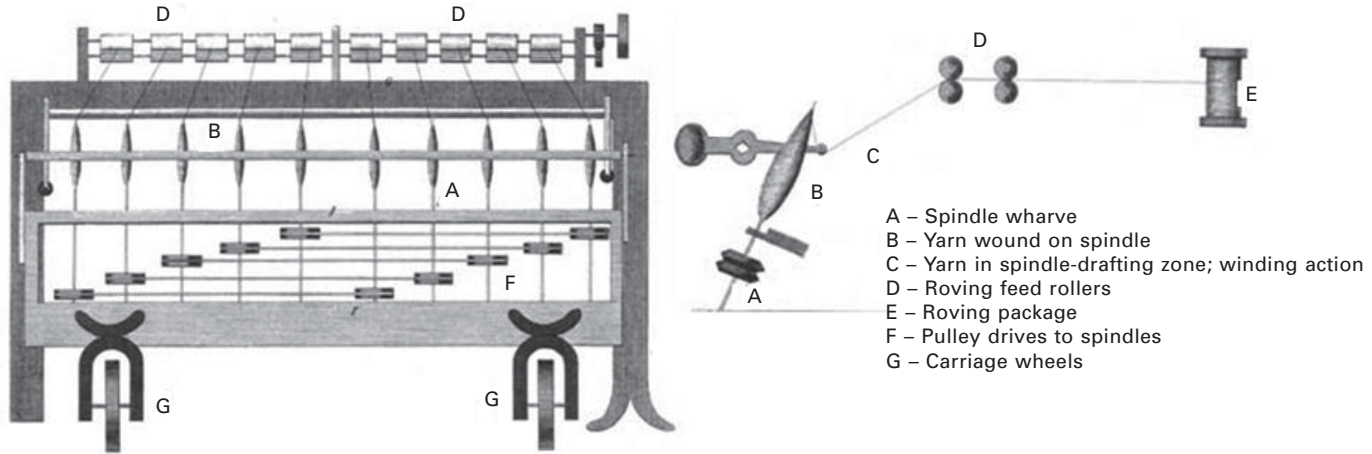

1.12 The spinning mule (adapted from [15]).

with wire-point, to give the point-of-tooth to point-of-tooth stripping action, is positioned to remove the disentangled fibres from the large drum, after the carding action. The web of fibres so formed could then be compressed through a trumpet guide into a continuous sliver. Subsequent development led to the use of a small drum, covered in wire points, and placed close to the large drum for feeding the fibre tufts onto the large drum. Lewis Paul is accredited with inventing in 1748 such a carding machine that was hand driven; Arkwright and Crompton later developed and improved carding machines into industrial systems.

From a technical viewpoint card slivers converted directly at roving frames do not readily produce uniform rovings, i.e. of consistent thickness along the length. This is because many of the fibres constituting a card sliver, although disentangled, will have trailing or leading hooked ends, or both, and fibre parallelism with the sliver axis will be low. Intermediate processes from the card to the roving frame were developed, termed drawing stages. These use the principles of roller drafting, but the mechanics differ depending on fibre length. Here it is useful to explain that the development of the industrial processes for yarn production differed depending on the fibre type, largely in respect of fibre length and fineness. The vast majority of yarn manufacturing machinery developments were aimed at improving the conversion of cotton and of wool into yarns. Card slivers from cotton fibres were produced on a cotton carding machine, which used flats instead of rollers, over the large drum (termed the main cylinder), and for wool slivers rollers were used over the large drum (termed the swift); the cotton card is often referred to as the 'revolving flats card' and the wool card as the 'roller-and-clear card'. Slivers from the former would be prepared for the roving frame by drafting several, say eight, in parallel through a 4-over-4 drafting system with a total draft equal to the number of slivers, i.e. eight, and combining the drafted material into one sliver of the same count as each of the input card slivers. This final sliver would be coiled into a can (i.e. a sliver can). The machine used to do this has become known as the 'drawframe' and the process 'a drawing passage'. Card slivers can have up to three drawing passages, depending on whether different fibres of similar lengths are to be blended and then spun. Following drawing, the drawn sliver (or drawframe sliver) is fed to the roving frame. The drawing process for wool slivers is similar, but the difference in machine systems is that a 2-over-2 unit is used and within the drafting zone an intersecting pin action is used to straighten the fibres.

Carding and drawing are only two of several preparatory stages that were developed to advance the spinning of cotton and wool fibres. Of major importance is the removal of unwanted or foreign matter that would lower the efficiency of the spinning process or render the yarn of low quality. For cotton the reference is opening and cleaning lines, while for wool wet-chemical processes are used under the term scouring. Owing to the fact that

the focus of this book is on spinning developments, a detailed explanation of the various preparatory processes in yarn manufacturing is outside the scope of this and other chapters. The reader is therefore referred to the textbook *Fundamentals of Spun Yarn Technology* [7] for greater in-depth technical information.

Carding can be used to produce a suitable material for directly spinning at the mule. This yarn manufacturing process is known as woollen spinning. Instead of a roving being fed to the mule, the feed material is called a 'slubbing'. Slubbings are formed by splitting the web removed from the swift by the doffer into ribbons and consolidating these ribbons by rolling them between two aprons which reciprocate whilst rotating [7, 8]. As the slubbings issue from the aprons they are wound into packages that are subsequently creeled at the mule spinning frame. This preparatory process therefore dispenses with the need for the roving frame for the production of mule spun yarns.

## 1.4 Ring spinning

In 1828 a further development of the water frame led to what became known as the Danforth 'throstle frame', after the inventor. It had a faster rotation of the flyer that made a humming sound similar to that of the song thrush, the dialect name being 'throstle'. Beside the higher fly speed and some difference in the arrangement of the drafting rollers, the machine was effectively the same as that used by Arkwright. The higher flyer speed caused instability of the spindle axis, resulting in a poor yarn and a lack of success for the system.

The actual rival to the mule, and one which subsequently superseded it, was the ring spinning frame, invented in 1832 by John Thorp. This system gave the most effective application of continuous drafting, twisting and winding, and at much faster production speeds than the intermittent drafting, twisting and winding of mule spinning. Ring spinning has remained today the most used method of yarn production even though a number of more highly productive systems were commercially developed during the twentieth century [18]. The main reasons for this are its flexibility in spinning a range of fibre types, its capability of spinning yarn at the finer end of the usable count range, and very importantly the structure and properties of the ring-spun yarn. The fundamental principles and the advancement of the ring spinning system are described in detail in Chapters 2 and 7. The next section of this chapter will consider the significant differences between the new methods and ring spinning. It is therefore appropriate to give brief description of the key features of the ring spinning method.

The ring spinning method utilises roller drafting for the attenuation of a roving feed. Over the many years of commercial development, improvements

of the roller drafting system have given more control of fibres within each drafting zone in order to obtain as uniform a yarn as possible. Apart from such engineered enhancements, this part of the ring spinning system is not fundamentally different from Lewis Paul's concept. The key features of the system, then, lie in the means used to combine the actions of twisting and winding.

From consideration of the yarn path of the flyer and bobbin device, as depicted in Fig. 1.13, it can be reasoned that in order to combine the twist and winding actions, the forming yarn must approach the spindle axis at a suitable angle,  $\beta$ . The apex of this angle through which the yarn passes must be the point, A, on the spindle axis. The yarn must then bend away from this point and subsequently bend a second time, at B, to approach tangentially, at the angle  $\phi$  in the horizontal plane, the circumference of the bobbin mounted coaxially with the spindle.

Thus, as the spindle rotates and the yarn path follows the circular trajectory, each completed circle of rotation will insert one turn of twist within the length AB. The right-angled bend at B will resist twist flow more than the bend at A. The twist therefore propagates up the yarn path towards the front rollers of the drafting system, instead of towards the yarn bobbin. To wind the yarn onto the bobbin during the circular trajectory, B must rotate at a slightly slower speed than the bobbin. The difference in speeds must be effectively equal to the speed at which the front rollers of the drafting system issue the drafted ribbon of fibres. Hence, a length of yarn will be wound onto the

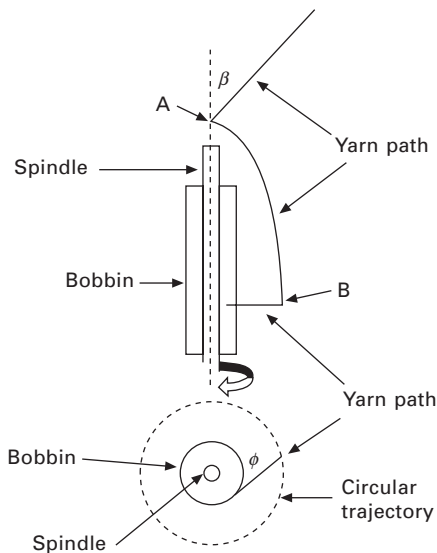

1.13 Yarn path for combined twisting and winding actions.

bobbin equal to the ribbon length issued from the front roller. The following equation expresses this balance in linear speed of the yarn:

$$D_b N_b - D_C N_B = d_f n_f \tag{1.17}$$

where

$D_b, N_b$  = bobbin diameter and rotational speed

$D_C, N_B$  = diameter of the circular trajectory and the rotational speed of B

$d_f, n_f$  = diameter and speed of the front rollers of the drafting system.

Since the ribbon of fibres leaves the front rollers at a fixed speed, it is evident from the equation that B must also increase in speed during winding. This means that angle  $\phi$  must increase as the bobbin diameter increases during winding.

In order to achieve the above dynamics without the use of the flyer and bobbin combination, John Thorp employed a ring, mounted on a rail, coaxial with the spindle and bobbin, to define the circular trajectory, and a C-shaped yarn guide, called a traveller, to circulate (travel) the ring. As Fig. 1.14 shows, the yarn passes through a lappet guide, which acts as the point A, then through the traveller and onto the bobbin. During the spindle rotation, the frictional drag of the ring on the traveller reduces the latter's rotation sufficiently to maintain winding at a constant speed onto the bobbin.

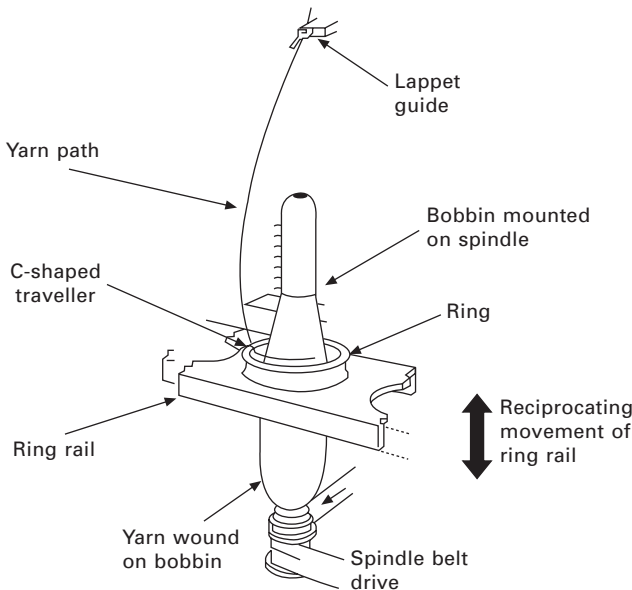

1.14 Key features of the ring and traveller system.

The traveller weight being only a few grams meant that much higher spindle speeds than had been used with the flyer system could be attained. It can be seen from equation (1.12) that for a given twist level,  $T$  turns  $\text{m}^{-1}$ , the speed ( $v_{fs}$ ) of issuing the fibre ribbon, under a constant draft, into the twisting zone could be significantly increased with increased spindle speeds. Since  $v_{fs}$  is also the wind-up speed of the yarn, it is in effect the speed at which the yarn is spun and may be called the spinning speed or the yarn production speed. The yarn production rate per spindle-hour,  $P$  (kg/sp-hr), would then be:

$$P = 6C_y v_{fs} / 100 \quad 1.18$$

where  $C_y$  is the yarn count (tex).

## 1.5 Modern spinning methods and developments: an overview

Although ring spinning has the advantage over earlier systems of higher production speeds and consequently reduced labour costs, the largest size of yarn package that could be built was limited by the ring size. Further the ring size limited also the traveller speed and thereby the spindle speed. This is because the frictional drag of the ring on the traveller can generate a high temperature at the ring–traveller interface; such temperatures can be reached where the traveller locally melts and central forces eject it from the ring. A significant amount of research and development (R&D) has been invested in improving the design of the ring–traveller combination and in the materials and surface coating that can be used to improve heat dissipation of the traveller and increased traveller speed.<sup>4</sup> However, the general consensus is that traveller speeds are limited to  $40 \text{ m min}^{-1}$  and therefore spindle speeds and production speeds are restricted.

The limitation of the package size while operating at the highest possible spindle speed brought with it increased labour cost for doffing and unwanted machine down-time during doffing. Modern ring-spinning machines exhibit very sophisticated engineering developments which circumvent many of these drawbacks, such as automated doffing and link-winding [7], so that larger packages can be built from spinning bobbins on an attached re-winding machine. These developments will be described in Chapter 7.

It should be evident from the above explanation that although combining the twisting and winding actions gave ring spinning major advantages over mule spinning, the combination also restricted the production speeds to which the ring and traveller system could be developed. Consequently, the

---

<sup>4</sup>A number of ring and traveller manufacturers quote maximum speeds of  $50\text{--}60 \text{ m min}^{-1}$ .

twentieth century saw rapid commercial developments of new spinning methods aimed at gaining major increases in production speeds compared to ring spinning.

It is interesting to note, here, that the common feature of these successful modern developments is that the twisting (or other means of imparting yarn strength) and winding actions occur separately but still simultaneously. This important difference from ring spinning enables higher spindle and production speeds, and many times larger yarn packages to be made. These advantages provided others such as fewer piecings on package, smaller floor space for a given production output, lower energy and labour cost per kg of yarn, reduce waste, etc. Despite these advantages, ring spinning still remains the dominant spinning process and seems likely to retain this position well into the twenty-first century. One very important reason for this is the structure and properties of ring-spun yarns compared with yarns from the new spinning methods. Chapters 6 to 14 describe the principles and developments of the more widely commercially available newer methods and Chapters 15 to 17 compare the various structures and properties of the yarns spun from these systems with ring-spun yarns. As a prelude to these chapters, consideration will now be given to the basic concepts for these newer methods in an attempt to group them into a useful classification.

As established above, the idea behind the newer methods is to separate winding from what may be considered as the action of consolidating the fibres together to impart strength to the yarn. Twist insertion cannot be used as the generic term for such consolidation, since a number of the newer methods use alternative means. In addition, most of the methods that employ twist have devised a new way of attenuation to obtain a suitable presentation of the fibre ribbon for twisting, while others retain the roller drafting system but utilise an alternative to the twisting principle of the rotating spindle. Let's begin with the methods employing twist of which there are essentially two, open-end spinning and self-twist spinning, although several techniques can be grouped under the former.

## **1.6 Twist spinning methods**

### **1.6.1 Open-end spinning method**

Open-end spinning, also referred to as O.E. spinning or break spinning, is a process in which the input material to the spinning system is highly drafted, ideally to the individual fibre state. The individual fibres are subsequently collected onto the tail end of a seed yarn (i.e. the open end) that is rotated to twist the fibres into the yarn structure and thereby form a new length of yarn: see Fig. 1.15. The spinning is continuous as the input material is continuously fed and fibres are continuously collected onto the open end of

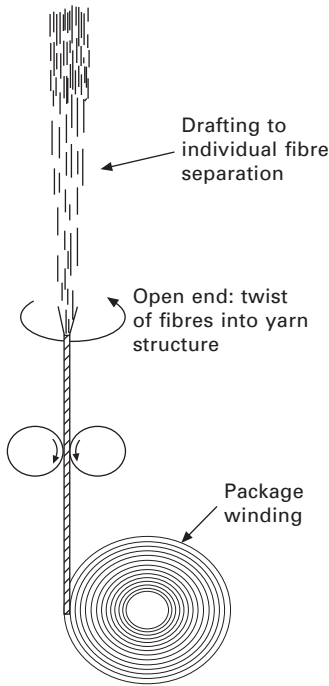

1.15 Principles of O.E. spinning.

a previously spun length. Currently two techniques employ the O.E. method commercially, namely rotor spinning and friction spinning. Both use a rotating roller having angled points projecting from their peripheral surface to remove a small number of individual fibres at a time and transport them to a collecting surface holding the yarn tail.

*Rotor spinning*

Figure 1.16 depicts the essential features of the rotor spinning system, which are

- The feed roller and feed plate
- A saw-tooth or pin-covered roller called an opening roller
- A tapered tube termed the transport channel
- A shallow cup called a rotor (a groove is cut into the internal peripheral surface, termed the rotor groove)
- A flanged tube (called the doffing tube) which faces the rotor base, coaxial to the rotor spindle
- A pair of delivery rollers that feed the spun yarn to the winding unit.

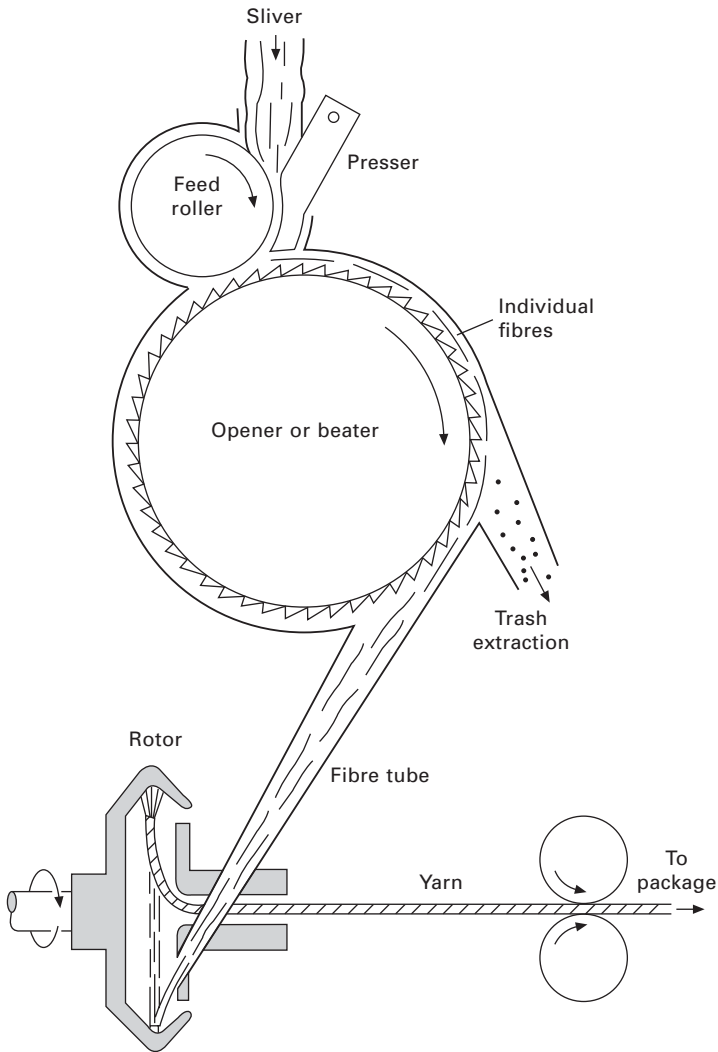

1.16 Basic features of O.E. rotor spinning.

Because material fed to the rotor spinning system can be drafted to the individual fibre state, sliver rather than roving is supplied to such machines. This eliminates one processing stage and adds to the economic advantages of the O.E. method. The feed roller and feed plate push the sliver into contact with the opening roller, which runs faster than the feed roller, thereby giving a high draft. The saw-teeth or pins on the surface of the opening roller hook the fibres and separate them from the sliver end (the sliver fringe) being fed towards it. The separated fibres are then removed from the opening roller clothing by air suction, down the transport channel and into the groove as the

rotor rotates at high speed; the suction is generated externally to the rotor. The rotor is therefore under a partial vacuum. As fibres enter the rotor they are collected in its groove to form a ribbon around its internal circumference. To initiate spinning, the tail end of a seed yarn, which is already threaded through the nip rollers and onto a yarn bobbin, is sucked into the doffing tube and becomes attached to the fibre ribbon, while simultaneously moving with the rotation of the rotor. This configuration of yarn tail enables one turn of twist to be inserted into it with each rotor revolution. This twist propagates towards the ribbon of fibres. Simultaneously with twisting the yarn tail, it is pulled from the rotor by the delivery rollers. The effect is the peeling of the fibre ribbon from the rotor groove, enabling twist to bind the fibres together onto the yarn tail and by so doing form a new length of yarn: see Fig. 1.17. The action gives continuous spinning, because as a length of fibre ribbon is removed and twisted to form the yarn, more fibres are collected to replace the length.

### *Friction spinning*

The friction spinning technique also uses the opening roller principle to highly attenuate a feed sliver. However, as illustrated by Fig. 1.18 the individualised fibres are collected in a groove formed by two rotating perforated drums. The tail of the forming yarn is also held within the groove by suction via the perforated surfaces, generated externally to the drums. The motion of the drum surfaces and their frictional contact with the yarn tail insert twist into the tail, so that fibres are bound onto the tail as it rotates and is simultaneously pulled along the length of the drums from the groove. Again the process is continuous because as a length of yarn is pulled from the collecting zone, an equal number of fibres to that removed will be added to the tail to form a new yarn length.

## 1.6.2 Self-twist spinning method

Often two yarns are twisted together, termed doubling or plying, in order to improve yarn properties, in particular yarn evenness, or to overcome downstream processing difficulties, for example in weaving worsted fabric where the warp yarns are not sized<sup>5</sup> and therefore a low yarn hairiness and high abrasion resistance are important [7]. Because of the cost issue of an additional processing stage (i.e. doubling) various techniques have been

---

<sup>5</sup>Size is a gelatinous film-forming substance, in solution of dispersion, applied to warp yarns before weaving to protect the yarns from abrasion in the healds, reeds and frictional contact with each other during the repeated shedding action of weaving. Generally only singles cotton yarns or short staple yarns are sized.

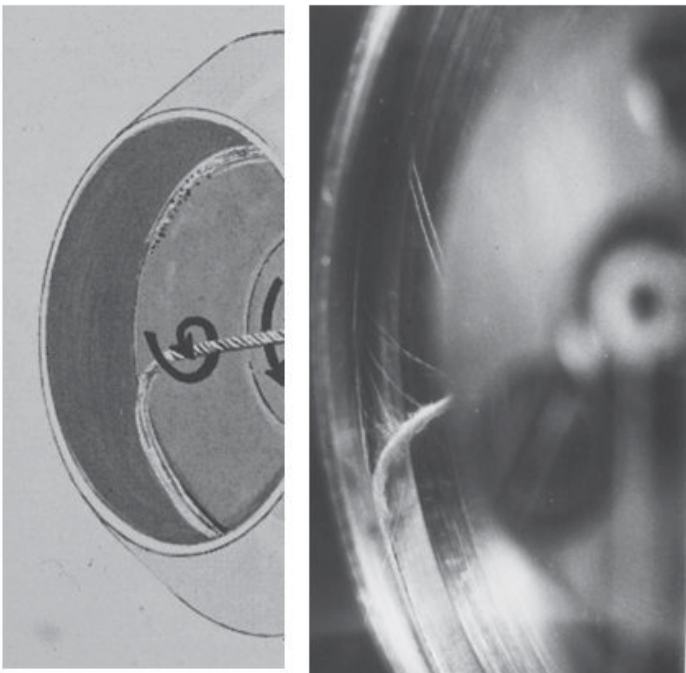
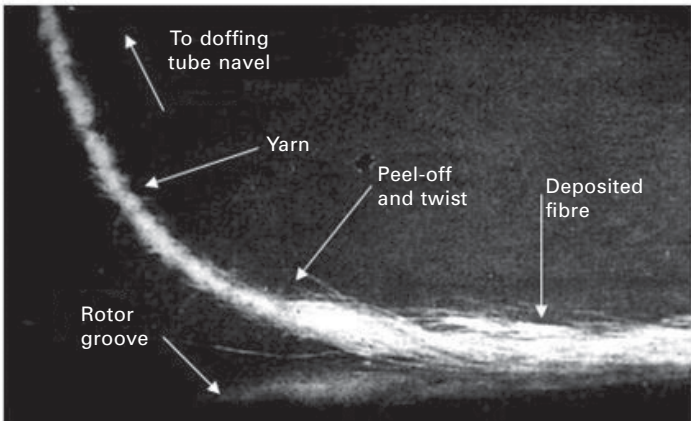

1.17 Yarn formation in rotor spinning.

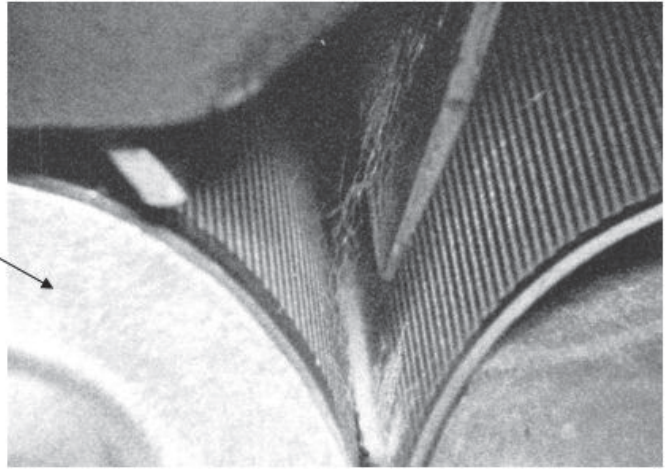
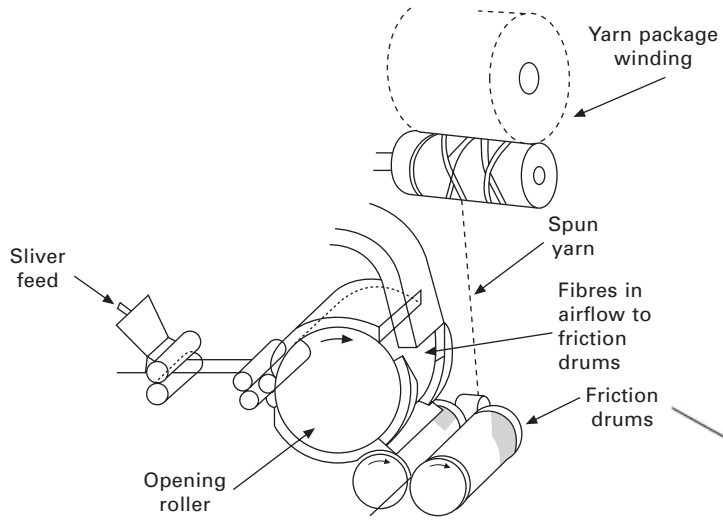

1.18 O.E. friction spinning.

developed which simulate a two-fold yarn using the ring spinning method. These usually involve feeding two rovings to each spindle position and employing a threading geometry so that in the spinning zone twist enters the individual drafted ribbons (or strands) as well as plying them together: see Chapter 6. The actual twist structure of these yarns, however, differs from that of a plied yarn, in that the direction of twist is the same in the strand and the resultant yarn, whereas with plied yarns the twist direction in the singles component will be opposite to that of the resulting ply. Consequently, plied yarns give a softer, more desired fabric handle. Importantly, the plied yarn structure has torque balance, so after-treatments are not necessary to overcome liveliness or snarling<sup>6</sup> in downstream handling of the yarn, particularly in knitting where spirality<sup>7</sup> can occur.

The self-twist spinning method provides a concept whereby two strands can be twisted and plied in a single-stage process to give a torque-balanced two-fold yarn suitable for knitting. The method is based on the false-twist principle, which is illustrated by Fig. 1.19. Here a strand (ribbon of fibres) is nipped by two pairs of rollers positioned an arbitrary distance apart. The rollers pass the strand through a rotating device positioned at X and at, say, a speed of  $V \text{ m min}^{-1}$  whilst the device rotates at  $N \text{ rev min}^{-1}$  in the direction shown. At the start of twisting, Z-twist<sup>8</sup> will be inserted in the strand as it passes through zone AX, and S-twist inserted as it moves through zone XB. As time passes, the degree of Z-twist will increase to a constant value of  $N/V$  per metre. The degree of S-twist will initially increase to a maximum

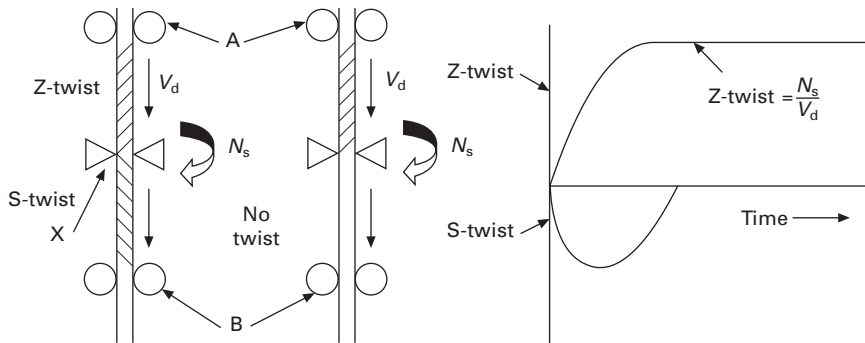

1.19 False twist principle.

<sup>6</sup>A yarn that has excessive tendency to twist around itself if held with insufficient tension.

<sup>7</sup>The tendency for the rows of interlinked loops (the course) running the width of a weft-knitted fabric to distort from their intended horizontal positions.

<sup>8</sup>The angled part of each letter (Z, S) indicates the visual angle at which fibres lie when the strand is twisted.

value and then decrease to zero. This is because each length of strand moving from zone AX into zone XB will become untwisted by the opposite torque present as it enters zone XB. The time over which the Z-twist increases to a constant and the S-twist first increases and then decreases to zero may be termed the transient period. At the end of this period the system is said to be in dynamic equilibrium; Z-twist will be seen in zone AX, but no twist will be present in XB. This twisting action is called false twisting because in dynamic equilibrium, the strand, although being twisted, has no twist when it leaves the twisting device. The self-twist method, however, utilises the transient state when the Z- and S- twists are at their maximum values in the two parallel strands being false twisted. At this point if the two strands are brought into contact with no further twist applied, each will exhibit an untwisting torque acting at the twist-changeover zone. This torque will ply the two strands together; some of the twist in each strand will be lost and replaced by an equal amount of ply twist. The yarn therefore becomes twist-balanced (i.e. torque-balanced) with no tendency to snarl.

Figure 1.20 illustrates the self-twist method. For continuous Z- and S-twist insertion, the twisting devices need to be repeatedly rotated clockwise then counter-clockwise, the change in direction being made when the maximum twist values are reached. We can see from the figure that each Z–S twisted strand can be related to a sinusoidal wave plotted on Cartesian axes, where the twist levels and directions are along the  $y$ -axis and the twisted length along the  $x$ -axis. Thus,  $\lambda$  represents the wavelength and in terms of the yarn length is called the cycle length,  $X$ . Making the sinusoidal wave analogy allows us to consider the relative positions of the lengths in each strand having the same twist direction in terms of the phasing of the waveforms. The two extremes of phasing are shown in the figure to be:

- In phase or  $0^\circ$  phased: when the two strands have their S- and Z-twist lengths, and their no-twist zones, coincident
- $180^\circ$  phased: when the strands are displaced such that the S-twist lengths coincide with the Z-twist lengths (i.e.  $a_1$  now faces  $b_2$ ).

When the strands are  $0^\circ$  phased their untwisting torque will cause them to self-twist (i.e. self-ply); when  $180^\circ$  phased they have opposing untwisting torque, self-twist does not occur and no yarn will be formed, each separately untwisting to their initial strand state. Figure 1.21 compares yarn configuration for  $0^\circ$  phasing with that of  $90^\circ$  phasing, and it can be seen that the former has the no-twist zones (or twist-changeover zones) of the strands coming together at the same place in the yarn, whereas the latter has the no-twist zones coinciding with the Z-twist (and S-twist) regions of one or other strand. Theoretically,  $90^\circ$  is the optimum phase angle as this would give the maximum yarn strength.

Various false-twisting arrangements can be used to produce self-twist yarns

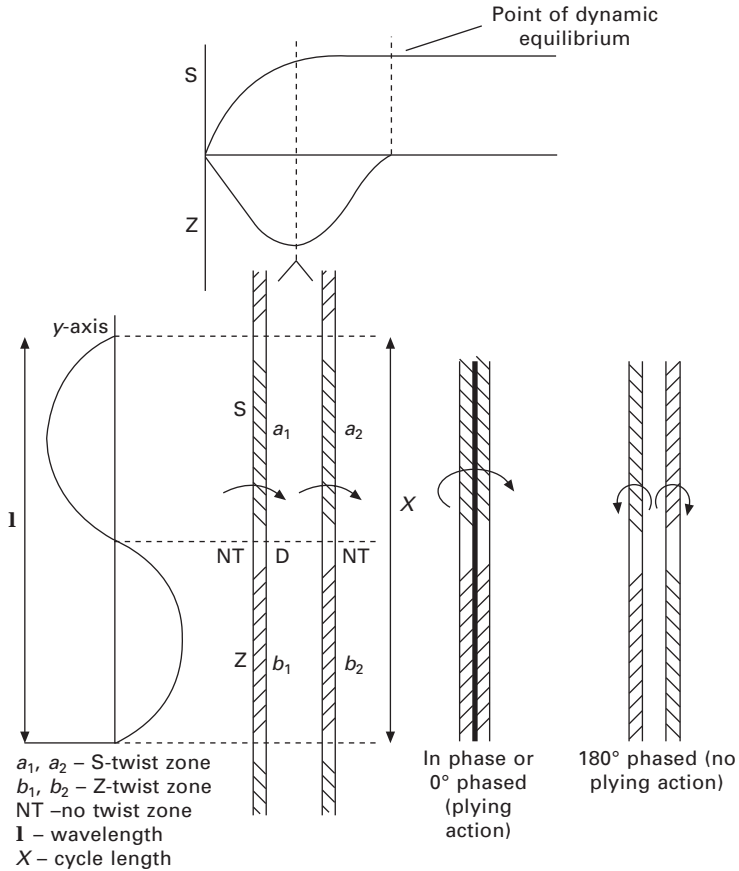

1.20 Principle of self-twist spinning.

(also called ST-yarns) [7, 22]. However, the commercial process known as Repco spinning utilises friction twisting by a pair of reciprocating rollers. The details of this system will be described in Chapter 12.

### 1.7 Wrap spinning methods

Besides the use of twist to consolidate the drafted ribbon of parallel fibres that constitutes a spun structure, surface fibres protruding from the ribbon or a continuous filament (or filaments) can be made to wrap (or bind) the fibre assembly to form a yarn with usable strength.

#### 1.7.1 Surface fibre wrapping

Two techniques are used: friction spinning and air-jet spinning.

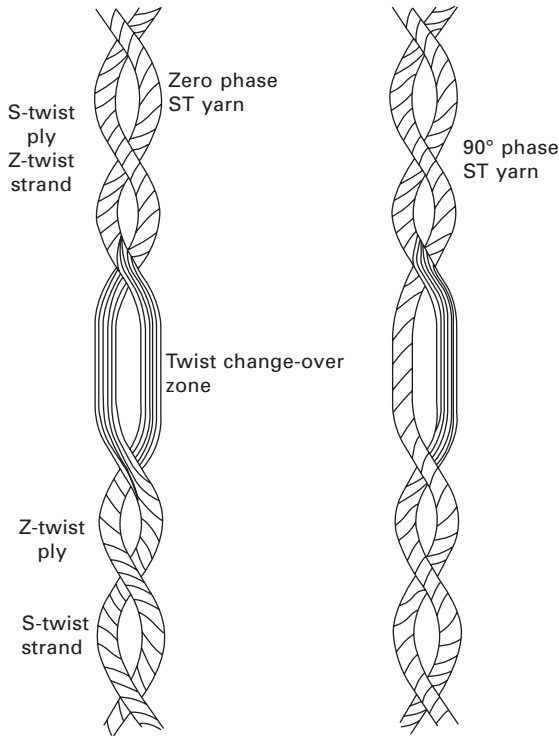

1.21 In-phase and 180° phased ST yarn structures.

### *Friction spinning*

With this technique a ribbon of fibres is fed from a roller drafting system along the V-shaped groove formed by the rotating friction drums. Fibres travelling from an opening roller unit are deposited onto the fibre ribbon. The friction drums insert a false twist into the fibre ribbon while wrapping the deposited individual fibres around it.

### *Air-jet spinning*

This technique is also known as fasciated yarn spinning [23, 24]. There are many variants of the technique, and Chapter 10 gives detailed descriptions of these. Here, for the purpose of illustration, only the basic technique will be considered.

Figure 1.22 portrays a typical air-jet spinning system which consists of a 3-over-3 high-speed roller drafting unit, two compressed-air twisting jets arranged in tandem, a pair of take-up rollers and a yarn package build unit. The basic jet design is also shown. This has a central cylindrical channel (the spinning channel) through which the fibre ribbon from the drafting unit

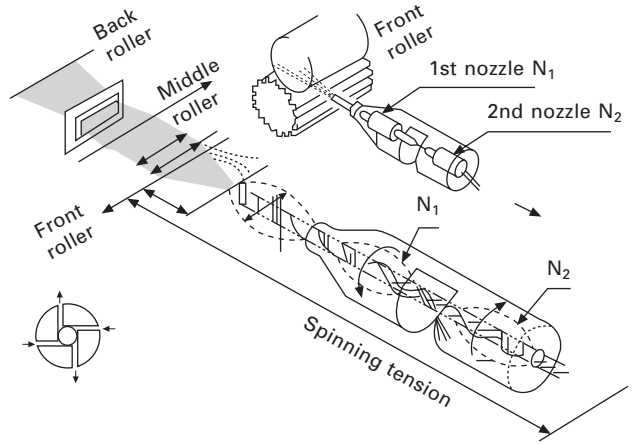
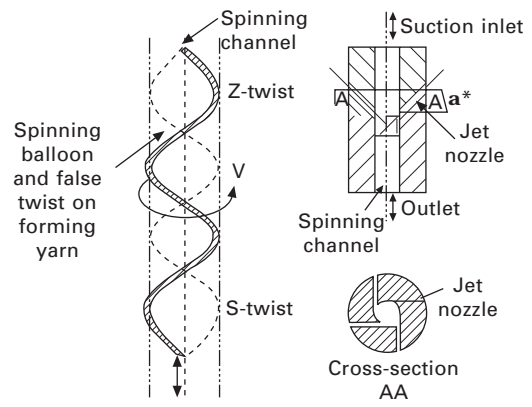
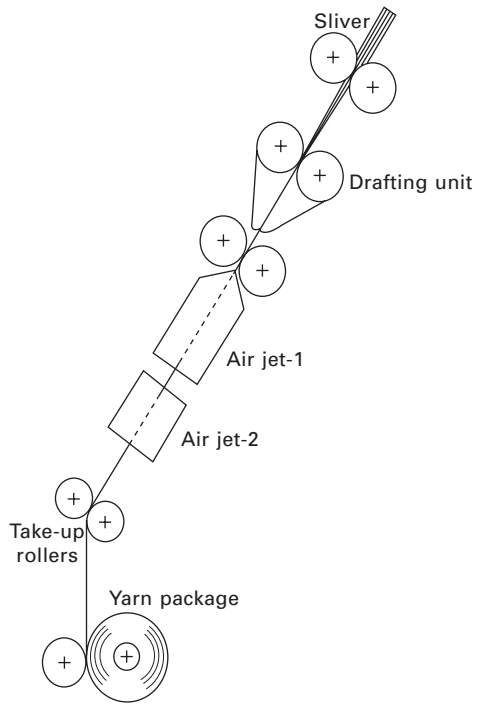

1.22 Principles of air-jet spinning.

passes. Inclined to the channel axis but tangential to its circumference are four nozzles through which compressed air is injected into the channel, creating a vortex airflow. Each jet of compressed air entering and expanding into the channel has two velocity components of airflow:  $V_1$ , a circular motion of the air around the channel circumference, and  $V_2$ , the movement of the air to the channel outlet. The suction at the jet inlet created by  $V_2$  gives automatic threading-up of the spinning process. Provided the drafted ribbon is not tautly held between the front drafting rollers and take-up rollers, the  $V_1$  component of flow rotates it, inducing a false-twisting action via a rotating standing waveform (a spinning balloon) while  $V_2$  assists movement of the twisted ribbon through the channel.

The nozzles of the first jet are set to give a counter-clockwise vortex producing a Z-S false-twist action; the second jet gives an S-Z false-twist action. The pressures applied to the jets are such that jet 2 has the higher twisting vortex. Although the jets impart a false twist, while doing so they do not have a positive hold on the ribbon being twisted. Because of this the S-twist from jet 2 propagates along the twisted ribbon and nullifies the Z-twist from jet 1, leaving some S-twist to travel towards the nip line of the front rollers. The balloon of the thread line near the front rollers tends to move edge fibres, leaving the nip line, away from the core of fibres being twisted together. Consequently, the leading ends of the edge fibres are not controlled by the S-twist propagating from jet 2; they are free to move with the vortex of jet 1, in the opposite direction (the Z-direction) to the twist in the core. The vortex of jet 1 therefore wraps the edge fibre around the twisted core, forming the wrap-spun or fasciated yarn.

### 1.7.2 Filament wrapping

Two techniques are used for wrapping a filament around a drafted ribbon of fibres to produce a wrap-spun yarn.

#### *Selfil spinning*

This process is an adaptation of the Repco system, replacing one of the alternately twisted strands with an alternately twisted filament (or filaments) [22]. The filament(s) and strand subsequently ply together, and because the filament is finer than the strand it wraps the strand in an alternating Z- and S-helix.

#### *Hollow-spindle spinning*

The hollow-spindle process [25] is the more common filament wrapping technique, the basic principle of which is shown in Fig. 1.23. The essential

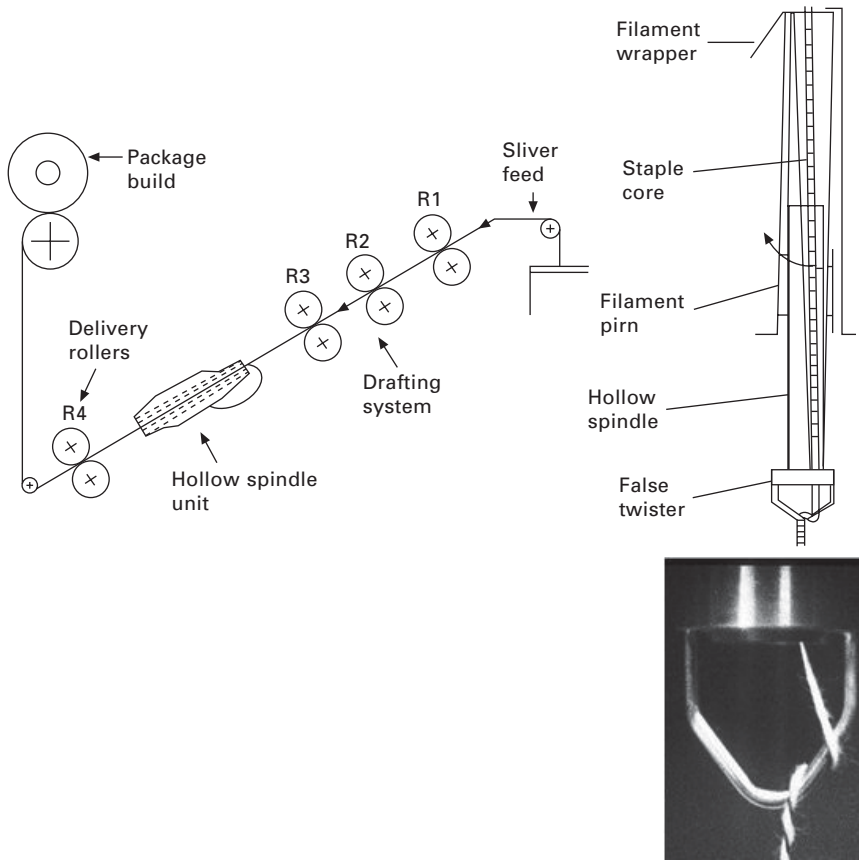

1.23 Hollow spindle wrap spinning.

features of the spinning line are a roller drafting unit, a hollow spindle on which is mounted a pin of filament<sup>9</sup>, a pair of take-up rollers and a package build unit. The spindle has an integral pin-type false twister located at its base (some systems have this located at the top). The ribbon issuing from the drafting unit and filament from the pin are pulled together through the hollow spindle and threaded to be false-twisted by the pin-type twister. With anticlockwise rotation of the hollow spindle, Z-twist propagates upwards from the pin-twister to the nip of the front rollers, which prevents any uncontrolled drafting of the length of twisted ribbon within the hollow spindle. Because the pin rotates with the spindle, the filament is not false-twisted. However, the effect of having the filament, with ribbon, threaded around the pin twister and nipped by the take-up rollers is to cause the filament to

<sup>9</sup>A small hollow bobbin on which the filament is wound.

wrap the ribbon as the ribbon is untwisted below the pin twister, thereby forming the wrap-spun yarn.

## 1.8 Conclusions

An extensive range of spinning techniques were developed during the twentieth century and a classification of those available today as commercial machines is given in Table 1.2, grouped according to the fundamentals of the spinning method on which they are based. Important aspects of any spinning system are the fibre types that can be spun, the spinnable count range, the economics of the process and (very importantly) the suitability of the resulting yarn structure to a wide range of end uses. All the systems listed in the table will spin man-made fibres, but because of processing difficulties and/or economic factors the commercial spinning of 100% cotton yarns is performed mainly

*Table 1.2* Classification of spinning techniques

Spinning method	Common feature	Technique	Type of twisting action during spinning	Type of yarn structure produced for fibre consolidation	Trade names
Ring spinning	Ring and traveller	Single strand twisting	Real	Twisted: S or Z	Various
		Double strand ply twisting	Real	Twisted: S or Z	Sirospun, Duospun
O.E. spinning	Breaking fibre mass continuity at twist zone	Rotor spinning	Real	Twisted: Z + wrapped	Various
		Friction spinning	Real	Twisted: Z + wrapped	Dref II
Self-twist spinning	Alternating S and Z folding twist	False twisting two fibrous standards positioned to self-ply	False	S and Z twisted	Repco
Wrap spinning	Wrap of fibrous core by either (a) filament yarn or (b) staple fibres	Alternating S and Z twist wrapping	False	S and Z twisted plus wrapped	Selfil
		Hollow spindle	False	Twistless core plus wrapped	Parafil
		Fasciated wrapping	False	Twisted core plus wrapped	Dref III
				Twistless core plus wrapped	MJS
				Twistless core plus wrapped and plied	Plyfil

on ring and rotor spinning systems. Wool is principally ring spun; the main reason is that the yarn structure gives the desired fabric properties, although a number of the other systems are used to produce wool yarns. With regard to process economics, the number of stages required to prepare the raw material for spinning, the production speed, the wound package size and the degree of automation are key factors in determining the cost per kilogram of the yarn, i.e. the unit cost. The following chapters will describe the technical details of each of the systems outlined and discuss these important aspects of yarn production.

## 1.9 References

1. McIntyre, J.E. (editor), *Textile Terms and Definitions*, The Textile Institute, Manchester, UK, 1995
2. Fourne, F., *Synthetic Fibers: Machines and Equipment, Manufacture, Properties: Handbook for Plant Engineering, Machine Design, and Operation*, Hanser Publications, Munich, 1999
3. Nakajima, T., *Advanced Spinning Technology*, Woodhead Publishing, Cambridge, UK, 2000
4. Demir, A. and Behery, H.M., *Synthetic Filament Yarn: Texturing Technology*, Prentice Hall, Upper Saddle River, NJ, 1997
5. Hearle, J.W.S. *et al.*, *Yarn Texturing Technology*, Woodhead Publishing, Cambridge, UK, 2001.
6. Perera, N., Effect of Filament Properties and Twist on the Bending Behaviour of Continuous Filament Yarns, PhD Thesis Leeds, 1991
7. Lawrence, C.A., *Fundamentals of Spun Yarn Technology*, CRC Press, Boca Raton, FL, 2003
8. Saville, B., *Physical Testing of Textiles*, Woodhead Publishing, Cambridge, UK, 1999
9. Booth, J.E., *Principles of Textile Testing: An Introduction to Physical Methods of Testing Textile Fibres, Yarns and Fabrics*, Butterworths, London, 1968
10. McCreight, D.J. *et al.*, *Short Staple Spinner's Handbook*, Institute of Textile Technology, Carolina Academic Press, Durham, NC, 1999
11. [http://en.wikipedia.org/wiki/Spinning\\_\(textiles\)](http://en.wikipedia.org/wiki/Spinning_(textiles)) (year 2010)
12. <http://gp.mercuryconnect.com.au/sswdg/Brief%20History%20of%20Spinning.html> (year 2010)
13. <http://kws.atlantia.sca.org/spinning.html> (year 2010)
14. <http://en.wikipedia.org/wiki/Distaff> (year:2010)
15. Morton, W.E., *An Introduction to the Study of Spinning*, Longmans, Green & Co., London, 1952
16. The Learning Centre, Museum of Science and Industry, Liverpool Road, Castlefield, Manchester M3 4FP, UK; email: education@mosi.org.uk, www.mosi.org.uk (year 2010)
17. [http://en.wikipedia.org/wiki/File:Spinning\\_Jenny\\_improved\\_203\\_Marsden.png](http://en.wikipedia.org/wiki/File:Spinning_Jenny_improved_203_Marsden.png) (year 2010)
18. <http://www.wooland yarn.co.uk/a-history-of-yarn-c147.html> (year 2010)
19. Rusca, R.S. and Brown, R., Some historical and technical aspects of spinning, *Textile Research Journal*, 1956, 26: 460–469

20. Dakin, G., A review of the development of cotton spinning machinery, *Journal of the Textile Institute Proceedings*, August 1951, 42(8): 457–478
21. Oxtoby, E., *Spun Yarn Technology*, Butterworths, London, 1987
22. Henshaw, D., *Self-Twist Yarn*, Merrow, Newcastle-upon-Tyne, UK, 1971
23. Atinson, K.R. and Henshaw, D.E., A Study in Spinning Fasciated Yarn, *J. Text. Inst.*, 3, 95–102, 1977
24. Du Point, Fasciated Yarn combines the best characteristics of spun filaments, *Textile World*, 134–135, 1974
25. Taub, E., Coverspun: a new yarn formation process, *Canadian Textile Journal*, March 1980, 97: 49–56

## Fundamental principles of ring spinning of yarns

---

R. S. RENGASAMY, IIT Delhi, India

**Abstract:** Ring spinning is one of a number of methods for assembling and twisting fibres to form a yarn. To fully explain the fundamentals of the ring spinning process, a review of the general principles of yarn formation is described. Various aspects of ring spinning such as principles of real twisting, roller drafting, inclination of drafting arrangement and offset of top rollers over bottom drafting rollers, spinning triangle and consolidation of fibres into yarn, rings and travellers, yarn tension and its fluctuations, balloon formation, mechanism of end breaks, package formation and application of ring spinning are discussed.

**Key words:** real twist, drafting rollers, offset, spinning triangle, ring, traveller, yarn tension, yarn balloon, end breaks, package formation.

### 2.1 Introduction

The human body has to be clothed for protection against the environment. Clothing needs to be flexible enough to allow the body to move easily. Clothes are three-dimensional structures made from joining two-dimensional structures called fabrics. Fabrics are usually woven or knitted structures. In the former, two sets of threads or yarns are interlaced in a regular pattern. In the latter, one set of threads is looped into others to provide bulk and elasticity to the fabric. The threads/yarns need to be flexible and are therefore made by assembling and twisting together flexible materials called fibres. Assembling and twisting staple fibres (fibres of discrete length of a few centimetres) into yarn is complex and the resulting packing fraction of the fibres in a yarn lies within the range 0.45 to 0.65. This means that there are many interstices in a yarn that are air channels and act as capillaries to transport sweat. During yarn spinning and subsequent post-spinning operations, many fibre ends protrude from the yarn to give hairiness to the yarn, which provides softness to the fabric and the resulting garment. Thus the presence of the interstices and hairiness contribute to the thermal comfort of clothing.

Ring spinning is one of a number of methods for assembling and twisting fibres to form a yarn of required thickness and strength to enable the yarn to sustain stresses during the various processes of conversion of yarn to fabric. To fully explain the fundamentals of the ring spinning process, a review of the general principles of yarn formation is first described.

## 2.2 Basic principles of spinning

The construction of yarn involves the linear and lateral positioning of the required number of fibres into a fibre strand and, by suitable means, consolidating the strand so as to utilise the strength of the individual fibres in order to give the yarn strength. To make yarn from a bunch of fibres which are randomly oriented, these fibres must first be aligned to form the fibre strand. The strand is then thinned, compacted and twisted, which increases the inter-fibre frictional forces giving the yarn sufficient strength so that when in use it can withstand tensions up to a specified value without breaking. The process of assembling and twisting together fibres to make yarn is called spinning. The spinning process therefore consists of two parts:

1. Assembling the required number of fibres
2. Imparting strength to that assemblage usually by the insertion of twist.

### 2.2.1 Fibre assembly in ring spinning

Assembling the required number of fibres prior to twisting is done by means of drafting of the fibre strand by roller drafting. In a roller drafting system, the rollers run at higher speeds from the back- to the front-rollers and in the process the fibres are redistributed over a longer length of the fibre strand and the fibre strand becomes thinner, i.e. with fewer fibres in the cross-section of the final fibre strand. The draft between any pair of rollers is defined as the ratio of the surface speed of succeeding rollers to that of the preceding rollers. The cotton sliver having 20,000–40,000 fibres is thinned down to the form of roving having 1500–3500 fibres by the previous process, ‘roving’. A 3-over-3 roller drafting system with double apron is used to draft the roving at the ring spinning machine. For cotton spinning, the drafts from the back-to the front-zones usually vary from 1.1 to 1.5 (break draft) and from 6 to 30 (main draft) respectively. Selection of a break draft depends on the fibre properties and is crucial in controlling the irregularity of the yarn. Break draft other than optimum exhibits stick-slip phenomena of fibre movement that gives rise to uneven yarn. For cotton, the number of fibres at the nip of the front rollers of the ring spinning machine is around 100 to 400 for the finest to the coarsest yarn respectively. These fibres on leaving the front roller nip are subjected to twisting in the downstream operation.

### 2.2.2 Insertion of twist

Various mechanisms can be used to give one of two types of twist insertion into a fibre: real or true twist and false twist.

*Real twist*

The principles of inserting real twist into an assembly of fibres are illustrated in Fig. 2.1. In Fig. 2.1(a) one end of the strand of the assembled fibres is held whilst the other end is made to rotate on the strand axis by a twisting device. Figure 2.1(b) graphically shows a bunch of filaments from a package placed on a rotating spindle being held in a bend configuration like a winch and gripped at the top. When the package is made to rotate, the filaments revolve about the central axis joining the gripping point and the package, consequently the inclined length of the assembled filaments gets twisted. Figure 2.1(c) depicts an open end of a yarn in contact with a fibre strand rotating about its axis. Fibres are caught on the yarn core and with additional rotation gradually the fibres towards the periphery also become twisted into the yarn. Hence, the twist proceeds from the inside to the outside of the new length of yarn being formed; this action is called twisting-out. The fibres caught on the core are highly twisted and the twist level gradually decreases from the core to the sheath.

*False twist*

If a fibre strand that is kept stationary by gripping it at both ends is twisted at some point in between, the strand length on each side of the twist insertion point, i.e. the twisting element, will obtain the same number of turns of twist, but with opposite directions (Fig. 2.2(a)). On moving the fibre strand through the point of twist insertion, the torque present in the upstream length will be cancelled as it passes the twisting element by the opposite torque present in the downstream length of the fibre strand. Thus, on passing the twisting element, the fibre strand would be twistless (Fig. 2.2(b)).

During spinning the fibre strand is supplied to the twisting device on a continuous basis and therefore the formed yarn has to be continuously wound onto a bobbin to form a package of yarn. The twisting of the fibre strand into a yarn and the winding of the yarn onto a bobbin may be carried out simultaneously or sequentially. Different spinning technologies are available wherein the method of twisting may be based on real or false twisting. The twisting is usually done by means of mechanical or aerodynamic actions, and ring spinning involves the former.

## 2.3 Ring spinning

Roving is continuously supplied from the creel to the back-drafting rollers of the ring spinning machine. The drafted fibre strand reaches the nip of the front rollers (Fig. 2.3). A bobbin is mounted on the rotating spindle. A small curved element, the 'traveller', is placed over the ring (dotted line). The yarn

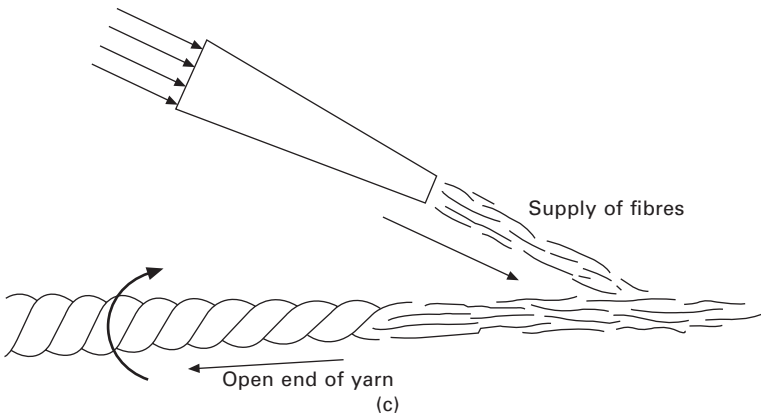
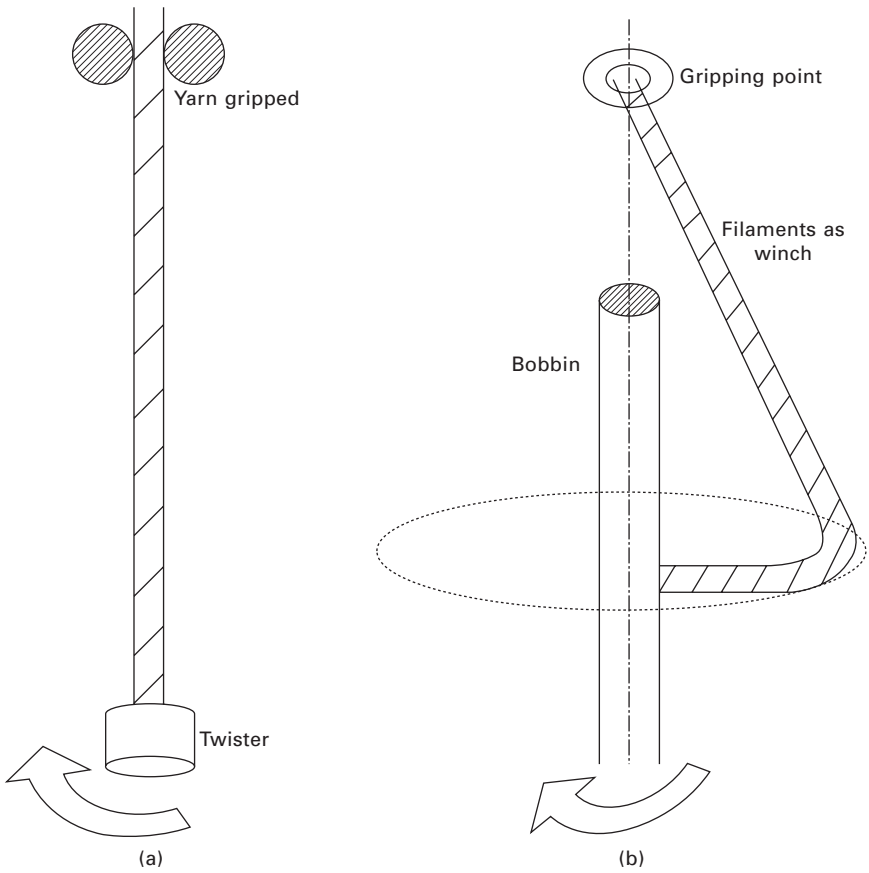

2.1 Principles of real twisting.

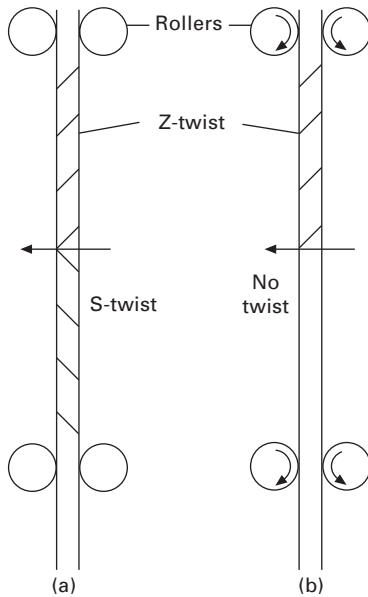

2.2 Principles of false twist insertion.

from the bobbin is taken underneath the traveller, passes through the guide eye and is then made to contact the emerging fibre strand at the front roller nip. The axes of the guide eye and spindle lie on the same line. The rotating bobbin pulls the yarn onto it and the yarn drags the traveller.

Due to the friction between the traveller and the ring, the traveller revolves around the package at a slower speed than the rotational speed of the package. The segment of yarn between the traveller and the guide eye, termed the balloon length as will be explained later, is pulled by the traveller and therefore also circulates the ring. On each revolution of the traveller, the balloon length rotates once on its axis to insert one turn of twist. Since the yarn is continuous, twist propagates through the thread guide reaching a point (termed the twisting point) very close to the nip of the front rollers issuing the fibre strand but not actually reaching the nip. The fibre strand from the front roller to the twisting point assumes a triangular configuration. The twist flow is therefore up to the apex of the triangle. The fibres forming the sides of the triangle are more tensioned than those towards the centre, and twist insertion is from the outside to the inside of the fibre strand, i.e. 'twisting-in'. The twist insertion rate is governed by the rotational rate of the traveller. However, for each rotation of the spindle faster than that of the traveller, the yarn is wound once around the bobbin.

The insertion of twist causes a contraction of the fibre strand (normally 2–3%) as it is converted into yarn, i.e. the continuous formation of the balloon

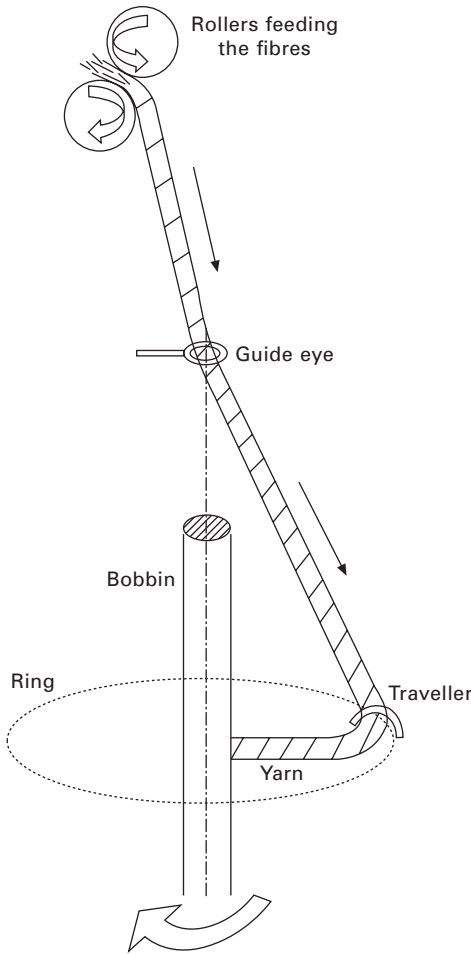

2.3 Yarn formation in ring spinning.

length. Consequently, the winding rate must equal the difference between the delivery rate of the fibre strand ( $V_F$ ) (or linear speed of the front drafting rollers) and the contraction of the strand on twisting. This is achieved by the traveller automatically adjusting its speed of rotation. The rate of winding yarn onto the package is therefore given by:

$$V_y = \mathbf{p}D_B(N_s - N_t) \leq V_F \tag{2.1}$$

where

- $D_B$  is the diameter of the package
- $N_s$  = spindle rotational rate, rpm
- $N_t$  = traveller rotational rate, rpm.

Normally the package diameter varies from 24 to 57 mm. For a delivery rate of the ribbon of fibres of about 25 m/min and a spindle speed of about 25,000 rpm, the difference between spindle and traveller speeds is only 332 rpm at the start of winding onto the empty bobbin and decreases to 140 rpm as a full bobbin is made; this is 1.32% and 0.56% of the spindle speed respectively. Thus, although twist is inserted by the traveller rotations, for practical purposes, the twist per unit length of yarn is expressed as the ratio of spindle rpm to front roller speed (m/min), as a substitute for the ratio of traveller rpm to front roller speed.

### 2.3.1 Spinning triangle and fibre consolidation

The fibre ribbon that emerges from the nip of the front drafting rollers is quite wide (especially when a high front zone draft is used) and converges towards the twist insertion point, forming what is called the spinning triangle; the base of the triangle is the nip line of the front drafting rollers, the apex of the triangle is the twist insertion point, and fibres forming the sides of the triangle are termed edge fibres. If the leading end of an edge fibre has less frictional contact with the other fibres, the frictional forces would not be enough for integrating the fibre into the yarn, leaving the leading end as a protruding hair. An edge fibre whose leading end is integrated into the fibre strand loses its tension when its trailing end is released from the nip of the front rollers. This may result in its trailing end projecting as a hair.

In a Z-twisted yarn, fibres in the right-hand side of the ribbon can fold over freely towards the left at the point of yarn formation. But fibres in the left-hand side are not similarly free to fold under towards the right because of obstruction by the top arc of the bottom-front drafting roller; thus, they are likely to be concentrated on the surface of the yarn (Morton, 1956). In a Z-twisted yarn, twist propagates from the right of the fibre convergence towards the left side of the spinning triangle. Therefore, fibres in the right-hand zone tend to be twist biased, i.e. receiving the greater insertion of twist and consequently offsetting the convergence point (i.e. twist insertion point) to give an asymmetrical spinning triangle. This twist bias reduces the height of the triangle at the right-hand side, but despite the imbalance, fibres in the triangle are well controlled and unlikely to escape the full twist consolidation to become hairs. However, a consequence of the imbalance is that most of the trailing hairs are formed at the left-hand side of the spinning triangle (Wang *et al.*, 1999).

During twisting of the ribbon, the constituent fibres follow helical paths that are longer than the yarn length being formed; those at the periphery of the ribbon follow the longest path, directly proportional to  $\sec^{-1}\alpha$ , where  $\alpha$  is the helix angle of the fibres at the surface of the yarn, i.e. the yarn twist angle. A greater tension will then be induced into these peripheral fibres

as they are twisted with those comprising the bulk of the ribbon to form a new yarn length. This causes them to push their way towards the centre of the fibre strand in order to relieve the stress, displacing the other fibres as they move. The displaced fibres get pushed outwards to become periphery fibres, and now, being more highly tensioned, their tendency is to move back towards the centre, displacing other fibres. This action among the fibres is iterative and results in them migrating from their initial radial position to other radial positions in a cyclic manner along their lengths. The edge fibres in particular move from the yarn surface to the core in a cyclic configuration along their lengths. This fibre motion is unique to ring spinning and is called 'tension migration'. It produces a high degree of interlacement of the fibres in the yarn cross-section, imparting strength to the yarn.

## 2.4 Ring spinning systems

The ring spinning system was initially developed to spin two types of natural fibres, cotton and wool. Cotton fibres are finer and shorter than wool; but both have a wide range of fibre length distribution. Accordingly, their processing requirements prior to ring spinning differ and hence the designs of ring spinning machines for processing these fibres are quite different, though the fundamental principles are the same. These staple fibres are processed through two separate systems: the short-staple or cotton system and the long-staple system.

Natural fibres provide better comfort and are poor in strength, whereas synthetic fibres have excellent durability characteristics and are poor in providing comfort. Blending of natural and synthetic fibres provides a compromise between comfort and durability and hence blended yarns such as cotton/polyester, viscose/polyester, wool/polyester and acrylic/wool are produced. To spin man-made fibres on either the long- or short-staple ring spinning system, their cut lengths have to be matched to the particular system.

## 2.5 Description of the ring spinning process

The current ring spinning machines are designed by default with certain features to perform the following main tasks:

- Attenuation of the feed material, i.e. 'roving', by a double apron roller drafting system, to the required fineness for the yarn (yarn count) to be made
- To consolidate the fibre strand that emerges from the drafting system into the yarn by twisting and thereby also imparting strength to the yarn
- To wind the resulting yarn on to a 'bobbin' in a precise and controlled

manner, termed ‘cop building’, so that the yarn package (cop) is suitable for storage, transportation and further processing.

The basic features of a ring spinning machine are shown in Fig. 2.4. The major functional elements are a creel to house the roving bobbins, a 3/3 double apron roller drafting system to attenuate the fibre strand, the twisting region from the front roller nip to the traveller, and the winding elements, comprising a spindle that holds the bobbin and a ring rail. There are many auxiliary/sub-elements that support or complement the functions of the main elements such as the main shaft, gears, belts and cam. However, only the major elements will be discussed hereafter.

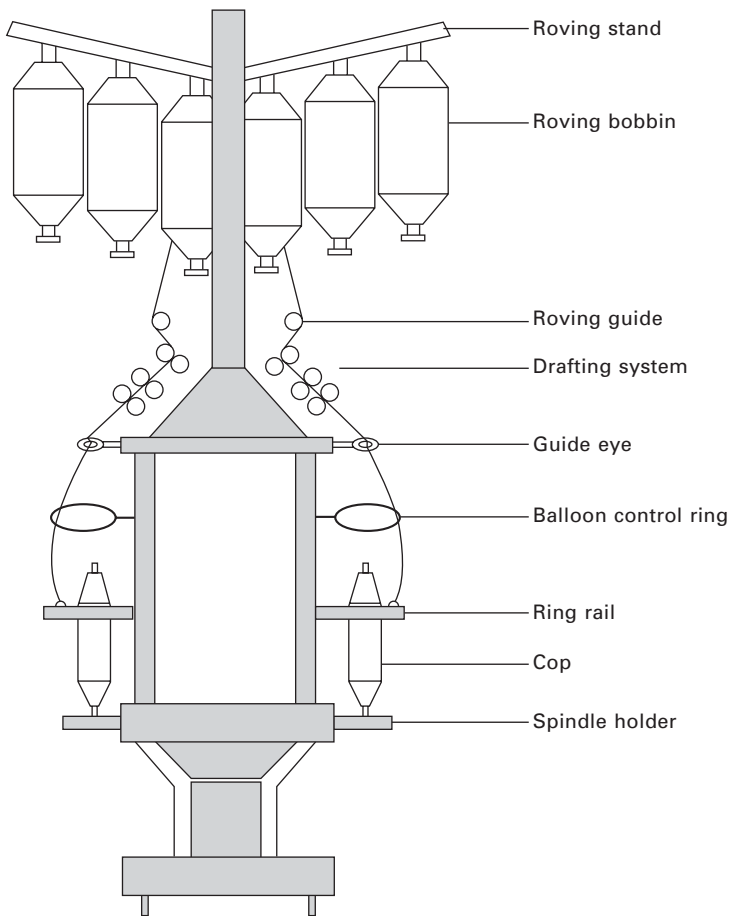

2.4 Ring spinning machine.

### 2.5.1 Roller drafting

A double apron drafting arrangement, comprising 3-over-3 rollers (Fig. 2.5), with long bottom aprons and short top aprons is mostly used for short-staple spinning. The rollers are made of steel and the top rollers are covered with synthetic rubber. The bottom rollers are positively driven whereas the top rollers are run by frictional contacts with the former. The top rollers must be pressed with relatively high force over bottom rollers by springs (mostly), air pressure or magnetically; different machinery manufacturers follow different approaches. The drafting force ( $F$ ) needed to draft the fibre strand comes in effect from the loading of the top rollers ( $N$ ) as  $F = \mu N$ . Selection of top roller force depends on the fibre types and volume of fibres present between the top and bottom rollers. The adjustment of top roller force may be done in steps or continuously, depending on the systems offered by the machine manufacturers. The purpose of having a synthetic rubber surface on the top rollers is to improve the contact between the fibres and top rollers. Top roller forces per roller shaft are within 100 to 300 N.

A force is applied to the top middle roller that presses the fibres to be gripped. As the fibre strand is progressively thinned down, the number of

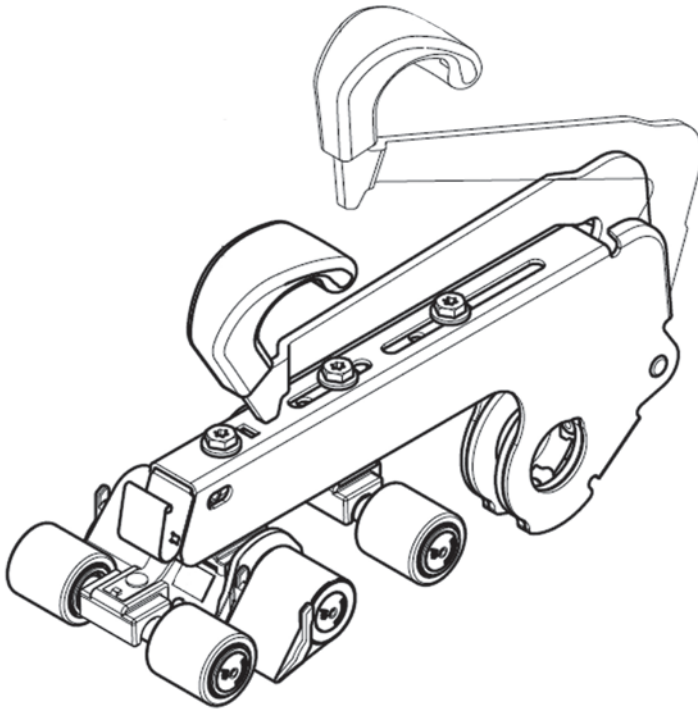

2.5 Double apron drafting system (courtesy of Suessen).

fibres at the nip of the middle roller of the ring spinning machine is very much less than that observed in the drawing machine. Under this condition the frictional forces between the fibres held by the middle rollers drop rapidly towards the front roller. A short fibre whose trailing end is released from the nip of the middle rollers has poor contact with the other fibres held by the middle rollers. This short fibre can be easily pulled out by the fibres held by the front rollers and it accelerates, reaches the front roller earlier than it should do. This leads to uncontrolled movement of short fibres, resulting in poor irregularity to the yarn. In this context, it is essential to extend the grip over the short fibres very close to the front rollers so that they are guided to move at the velocity of the middle rollers till they reach very close to the front rollers. For this, two revolving aprons (made of synthetic materials) kept under tension by cradles/nose bars are driven by the middle rollers to guide the fibre strand in the front drafting zone. In order to exert controlled pressure on the fibres, the top apron is forced by spring pressure against the lower apron and also constrained with an exit opening close to the front rollers. With this arrangement, the forces acting on the fibres due to the external load applied on the middle top roller do not drop rapidly towards the front rollers (Fig. 2.6). Thus, the frictional forces between the fibres held by the middle rollers do not drop rapidly towards the front rollers. This helps in regulating the motion of the short fibres. The exit opening between the aprons is determined by spacers or distance clips of different sizes that must conform precisely to the volume of fibre strand; the ‘rule of thumb’

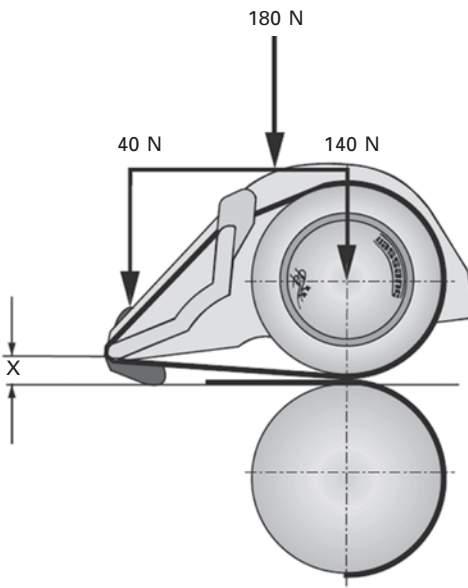

2.6 Change of force on drafting system (courtesy of Suessen).

is smaller sizes correspond to finer yarns, but the correct setting of the gap is established by practice. For a give yarn count, the specific gravity, crimp and rigidity of fibres must also be taken into account as these parameters differ with the type of fibres processed and accordingly suitable spacers must be selected. Spacers are inserted between the nose bar of the lower apron and the cradle edge of the top apron at the exit opening. Fibre guidance length (from the nip of the middle roller to the apron exit) depends on the length of fibres to be processed and is set by selecting cradles of appropriate lengths.

The bottom roller surfaces (except the middle roller) are helically fluted to flex the fibres between the flutes so as to improve their grip over the fibres. The middle bottom roller is knurl fluted to improve the static friction between the apron and the roller so that apron slip is kept under control. Knurled flutes improve the service life of aprons compared to helical or axial flutes.

*Top rollers*

The top rollers are double-boss rollers supported in their centre sections by the forcing arm. Available variants of double-boss rollers are fast boss rollers and loose boss rollers. In the former, two bosses on the left and right form as a single and can be rotated only in unison. In loose boss rollers, two bosses can be rotated independently. The roller bodies are mounted on one or two rows of radial ball-bearings.

The shore hardness of synthetic covering materials used on the top rollers varies in the range 63–83°. The suggested shore hardness values based on the recommendations of Reiter for G-35 ring spinning machines with Ri-Q drafting arrangement are given in Table 2.1.

Hard coverings on the top roller have better wear resistance and reduce

*Table 2.1* Hardness of top roller covering

Fibres	Optimum yarn count (Ne)	Hardness (°shore)
100% cotton	28–160	63 (front)
Blends of cotton and man-made fibres	40–90	} 83 (back) 80 (middle)
100% man-made fibres	50–90	
100% cotton	20–27	70 (front)
Blends of cotton and man-made fibres	30–39	} 83 (back) 80 (middle)
100% man-made fibres	30–49	
100% cotton	10–19	75 (front)
100% man-made fibres and blends of cotton and man-made fibres	18–29	} 83 (back) 80 (middle)
100% cotton	5.5–9	
100% man-made fibres and blends of cotton and man-made fibres	5.5–17	} 83 (front) 75 (back) 80 (middle)

the tendency of the fibres to lap around the rollers. Soft coverings increase the area of contact between the rollers and the fibres but have low wear resistance. When spinning finer yarns, the number of fibres at the front roller nip is less, providing fewer inter-fibre contacts. As a consequence, the fibres at the front roller nip can be easily spread out, forming a spinning triangle with a large base leading to inefficiency in twist insertion, i.e. difficulty in trapping the edge fibres into the yarn. Having low shore hardness on the front top roller encloses the fibre more completely and provides better gripping of fibres while processing finer yarns. For coarser yarns or synthetic fibre yarns, harder coverings are used to reduce roller lapping and wear on the covering. For the back roller, hard coverings are recommended since the roving, with a large number of fibres with a twist that binds them, does not call for additional grip on the fibres.

There is one inherent limitation on the way the bottom apron is currently driven by the bottom roller. This can be explained as follows. Let the tension on the apron under static conditions be  $T_i$ . During operation, the apron experiences a frictional force,  $dF$ , over the arc of the bottom roller and subsequently its tension at the roller nip reaches a maximum,  $T_2 = T_i + dF$ ; the tension just before passing around the roller is  $T_1 = T_i - dF$ . As the apron passes around the roller, it extends by an amount  $e_1$  proportional to  $T_i + dF$ ; this extension is released as excess length of the apron into its working region where it guides the fibres in the front drafting zone, thereby affecting the controlled fibre motion. To alleviate this problem, bottom cradles that guide the apron have a convex design that accommodates the excess length, improving fibre control in the front drafting zone.

#### *Offset of top roller over bottom roller*

In ring spinning the front and back top rollers' central axes are displaced forward and backward respectively by 2–4 mm relative to the corresponding central axes of the bottom rollers. A further advantage of forward offset of the front top roller is the decreased height of the spinning triangle which enables the twist to flow very close to the nip of the front rollers. The back top roller is backward offset in order to obtain the best control of fibre motion, as fibres leaving the nip have to flex in passing over the curved surface of the bottom back roller.

Figure 2.7 illustrates the importance of the top front roller offset. If the offset is, say,  $x$  mm, the angle,  $\theta$ , subtended by the applied force  $F$  of the top roller can be calculated from the following equation:

$$D \sin \theta = x \quad 2.2$$

where  $D$  is the sum of the top and bottom radii. The tangential component of the top roller force  $F_t$  (Fig. 2.7) is given by

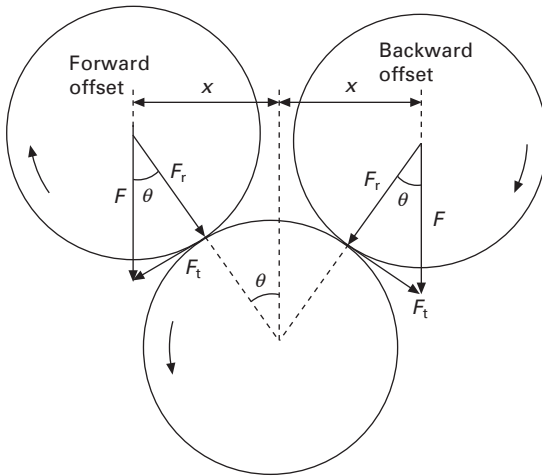

2.7 Tangential components of top roller force.

$$F_t = F \sin \theta \tag{2.3}$$

The tangential component of the top roller force (a small fraction of the applied force,  $F$ ) assists the rotation of the top roller in the intended direction. This benefit would not be available for a backward offset of the top roller; rather the tangential component would counteract the rotation of the top roller, necessitating the application of a higher load on the top roller.

### 2.5.2 Inclination of the drafting arrangement

The drafting system is mostly inclined at an angle  $\alpha = 45^\circ$  with respect to the horizontal plane. Fibres emerging out of the front rollers converge and form the spinning triangle. The angle of inclination is therefore one factor which determines the height of the spinning triangle.

The flow of twist from the yarn balloon is partially blocked due to the friction of the yarn at the guide eye, and a lower level of twist propagates up to the apex of the triangle and no twist passes the apex, hence the fibres in the spinning triangle are twistless. The yarn balloon tension is, however, readily transmitted to the apex of the spinning triangle and into the fibres forming the triangle. Considering the slippage of fibres under tension at the triangle apex, high mean tensions and/or tension fluctuations will cause most yarn breaks to occur at the spinning triangle.

With a low inclination angle of the drafting system, the angle of wrap of the fibre strand over the curvature of the front bottom drafting roller is large, resulting in a long spinning triangle (Fig. 2.8). A large inclination forms a short spinning triangle. The importance of the height of the spinning triangle

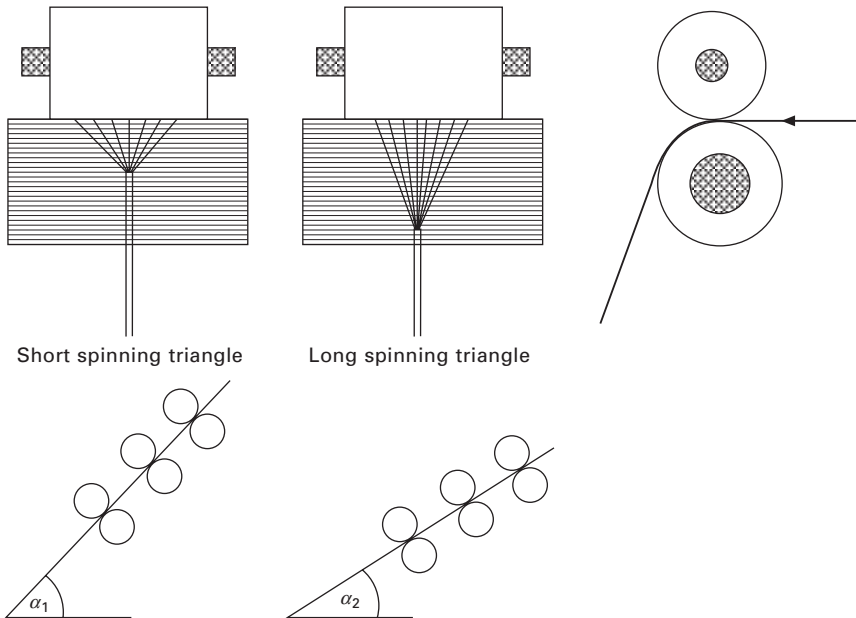

2.8 Inclinations of drafting arrangement and sizes of spinning triangle.

is in respect of the frequency of yarn breaks (i.e. the end breakage rate) during spinning. A short triangle is a small weak point whereas the longer one is a long weak point; hence the longer spinning triangle results in more end breaks. However, a very short spinning triangle will have a large apex angle; the edge fibres would be deflected strongly before their leading ends are bound into the apex of the fibre strand. Few edge fibres may escape as fly; others may get bound-in at their leading ends only, with their trailing ends subsequently projecting from the yarn surface as hairs, and thus a hairy yarn is produced.

### 2.5.3 Ring and traveller

The traveller, supported by the ring and in combination with the rotation of the spindle, circulates the ring to insert twist to the fibre strand and simultaneously enables winding of the continuously spun yarn length onto the bobbin.

In designing the ring–traveller combination, the stability of rotation of traveller and the yarn clearance between traveller and ring (Fig. 2.9) are of importance. Travellers are therefore made with different cross-sections (wire profiles) suitable for different fibres and yarns (Fig. 2.10). The traveller circulates the ring at a very high speed,  $N_s$ , and the centrifugal force generated



2.9 Ring and traveller combinations (courtesy of Bracker).

**f Flat wire**

Good seating on the ring, hence low hairiness results. Suitable for fine cotton yarn and viscose

**dr Semi-round wire**

For blends, cotton and synthetics. Good results with low twisted (knitting) yarn. For high speeds

**udr Ultra semi-round wire**

For cotton, blends and synthetics. This wide profile offers large contact surface and good heat conduction at high speeds

**fr Flat round (combined profiles)**

For acrylics, special synthetics and core yarn. Flat toe, round yarn passage, for higher speed

**r Round wire**

For wool, synthetics and core yarn, for lower speeds. Small area of contact with ring leads to instability

**drh Semi-round high**

Special section, designed for SU travellers

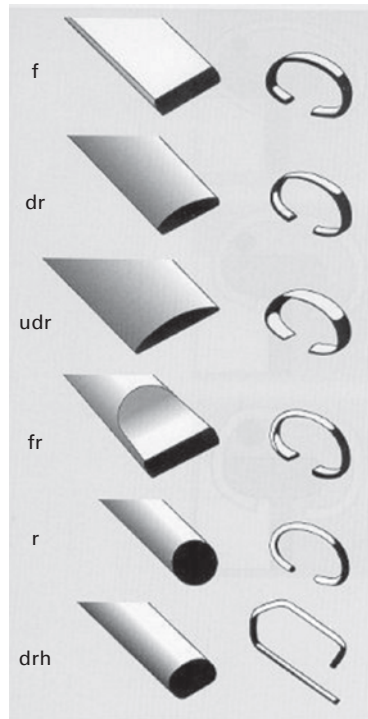

2.10 Cross-section of travellers (courtesy of Bracker).

on it results in a high contact pressure at the traveller–ring interface of the order of  $35 \text{ N/mm}^2$  and this leads to frictional heat and wear. The frictional wear of the traveller is proportional to  $N_s^3$ . The temperature at the interface can reach  $400$  to  $500 \text{ }^\circ\text{C}$  and the traveller undergoes annealing and ‘burns out’. At these high pressures and temperatures, micro-welding of traveller fragments occurs at the interface and the ring gets roughened, leading to instability of the traveller motion. To decrease the temperature build-up on

the traveller and its wear, the contact area between the ring and traveller at the inner side of the ring has been increased over the years. Orbit and SU ring-travellers have a high contact area between them (Bracker, 2008; Vijayakumar, 2003). These designs provide better running stability to the traveller and better heat dissipation. To greatly reduce the wear, both the ring and the traveller are hardened by special treatments. The traveller is nickel plated to reduce the friction on the ring. Rings are made of high-carbon cold-drawn seamless steel tubes that give high strength and durability. The hardness of the traveller is, however, less than that of the ring so that most of the wear occurs on the traveller; traveller replacement is less expensive. A special hardening process is applied to the traveller for better metallurgical grain structure. Often the traveller is treated by chemical diffusion for deeper penetration into the base material of additives to improve the elongation of the traveller for easy insertion onto the ring.

#### 2.5.4 Yarn tensions and balloon geometry in ring spinning

The following notations are used unless otherwise specified:

- $V_F$  = Feed rate of fibres from the delivery rollers
- $V_R$  = Ring rail speed
- $D_B$  = Bobbin diameter
- $\mu_{YL}$  = Coefficient of friction between the yarn and guide eye
- $\mu_{YT}$  = Coefficient of friction between the yarn and traveller
- $\mu_{RT}$  = Coefficient of friction between the ring and traveller
- $\beta_1$  = Angle of wrap of yarn at lappet/guide eye
- $\beta_2$  = Angle of wrap of yarn at traveller
- $m$  = Mass per unit length of yarn
- $R$  = Ring radius
- $\omega$  = Angular velocity of traveller
- $C$  = Centrifugal force on traveller =  $MR\omega^3$
- $F$  = Friction drag on traveller
- $M$  = Traveller mass
- $H$  = Balloon height
- $T_{B1}$  = Yarn balloon tension immediately below the guide eye
- $T_{B2}$  = Yarn balloon tension above the traveller
- $T_W$  = Yarn winding tension
- $C_y$  = Yarn tex
- $D_R$  = Diameter of ring
- $N$  = Reaction force on the traveller from the ring
- $\theta_1$  = Angle of yarn in the balloon with respect to the  $y$ -axis
- $\theta_2$  = Angle of yarn in the balloon with respect to the  $x$ -axis

- $\theta_3$  = Angle of yarn in the balloon with respect to the  $z$ -axis
- $\theta_4$  = Angle of inclination of the traveller with respect to  $y$ -axis
- $R_B$  = Bobbin radius
- $\alpha$  = Angle of lead of the yarn, defined as  $\sin\alpha = R_B/R$
- $f$  = Vibration frequency of a string/yarn
- $\omega$  = Angular velocity of yarn =  $2\pi f$
- $F_D$  = Horizontal component of air drag
- $\rho_A$  = Density of air
- $C_d$  = Air drag coefficient
- $d_y$  = Yarn diameter
- $r_{\max}$  = Maximum radius of the balloon

In ring spinning the yarn length between the traveller and guide eye is made to circulate the spindle axis which passes through the guide eye. This is external to the yarn axis. As the yarn length circulates the spindle axis it adopts an arc shape. The speed of circulation of the arc shape gives it the visual appearance of a balloon shape. The yarn length is consequently called the balloon length, and its circulation balloon rotation. The revolving balloon is similar to a circularly polarised standing wave (Fig. 2.11). The balloon may form one or more nodes depending on the yarn length and its frequency of revolution and the tension on the yarn. Considering the yarn balloon as the circularly polarised transverse vibration of a string, the velocity of propagation of the transverse waves along the yarn is given by:

$$c = \sqrt{\frac{\hat{E} T_{B1}}{m}}^{1/2} \tag{2.4}$$

The length of node,  $l$  ( $= \lambda/2$ ), is related as

$$\frac{l}{2} = \frac{c}{2f} = \frac{1}{2f} \sqrt{\frac{\hat{E} T_{B1}}{m}}^{1/2} \tag{2.5}$$

$$\frac{l}{2} = \pi \sqrt{\frac{\hat{E} T_{B1}}{E w^2 m}}^{1/2} \tag{2.6}$$

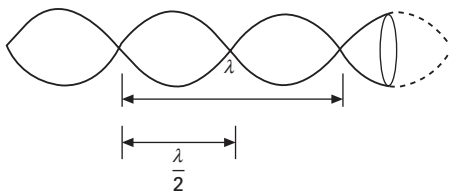

2.11 A circularly polarised standing wave on a rotating string.

when

$$P = \frac{\hat{F} T_{B1} \hat{\omega}^{1/2}}{\hat{m} \mathbf{w}^2} \tag{2.7}$$

the value of  $P$  can be written as

$$P = 2992 \frac{\hat{F} T_{B1} \hat{\omega}^{1/2}}{\hat{C}_y N_t} \text{ (cm)} \tag{2.8}$$

In the absence of air drag force, the yarn balloon lies in the axial plane (the  $x$ - $z$  plane). The height of the balloon when only one node is formed, this being at the apex, is given by  $H = \mathbf{p}P$ . If  $H/P > \mathbf{p}$  then a balloon of multiple nodes will occur. The yarn tension in the yarn and the revolving speed of the traveller influence the dynamics of the balloon. The spinning, balloon and winding tensions are related by the Capstan equation:

$$\frac{T_{B1}}{T_S} = e^{\mathbf{m}_{kL} b_1} \tag{2.9}$$

$$\frac{T_W}{T_{B2}} = e^{\mathbf{m}_{kT} b_2} = \frac{1}{a} \tag{2.10}$$

Further, the balloon tensions are shown to have the relationship:

$$T_{B1} = T_{B2} + \frac{1}{2} mR^2 \mathbf{w}^2 \tag{2.11}$$

The position of the traveller and the various forces acting on it under steady state are shown in Fig. 2.12. While winding the yarn, the traveller mostly contacts the inner side of the flange of the ring. The centrifugal force generated by the high traveller rotational speed acts on the inner side of the flange and is much greater than the horizontal component of the winding tension. The component forces at equilibrium in the horizontal, tangential and vertical planes are:

$$C + T_{B2} \cos\theta_1 = T_W \cos\alpha + N \cos\theta_4 \tag{2.12}$$

$$T_W \sin\alpha = \mu_{RT} N + T_{B2} \cos\theta_2 \tag{2.13}$$

$$T_{B2} \cos\theta_3 = Mg + N \sin\theta_4 \tag{2.14}$$

From the above equations, the yarn balloon tension above the traveller is

$$T_{B2} = \frac{a \mathbf{m}_{RT} MR \mathbf{w}^2}{\sin a \cos q_4 + \mathbf{m}_{RT} \cos a - a(\mathbf{m}_{RT} \cos q_1 + \cos q_4 \cos q_2)} \tag{2.15}$$

$$\sin q_4 = \frac{a \mathbf{m}_{RT} (T_{B2} \cos q_3 - Mg)}{T_{B2} (\sin a - a \cos q_2)} \tag{2.16}$$

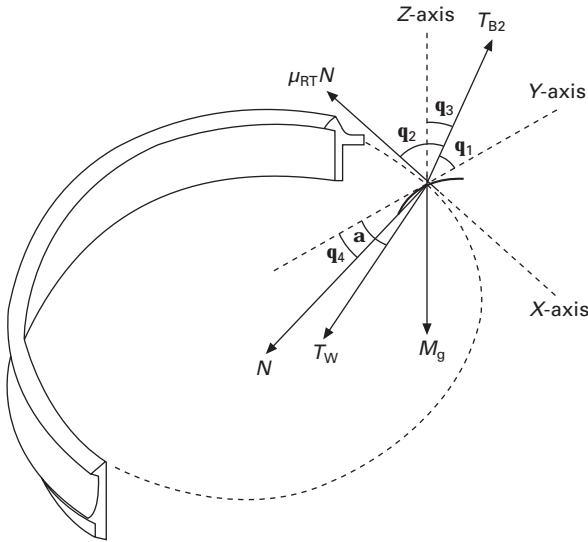

2.12 Forces acting on traveller during spinning.

When  $r_{\max} = R$ ,  $\theta_3 = 0$ , then  $\cos \theta_3 = 1$ . With no air drag,  $\theta_2 = 90^\circ$ ,  $\cos \theta_2 = 0$ ;  $\theta_1 = 90^\circ$ ,  $\cos \theta_1 = 0$ ; and  $\theta_4 = 0^\circ$ ,  $\cos \theta_4 = 1$ .

When the ring-traveller friction is small, further approximation leads to:

$$T_W = \frac{m_{RT}MRw^2}{\sin a} \quad 2.17$$

$$T_{B2} = \frac{am_{RT}MRw^2}{\sin a} \quad 2.18$$

The tensions on the yarn depend on the friction at the ring-traveller interface, the mass of the traveller, the ring radius, the traveller speed and the angle of lead; the last of these depends on the bobbin diameter (full/empty bobbin or the position of the ring rail). To reduce the possibility of high tension at the start of winding the yarn onto the bare bobbin, the ratio of diameter of bobbin to ring diameter is kept at  $\geq 0.5$ .

#### *Air drag on yarn tension*

With the presence of air drag under normal operating conditions, each yarn element of the balloon length deviates from the axial plane slightly more than its predecessor. The balloon length is therefore longer than in the absence of air and it inclines towards the rotational direction of the traveller. In the absence of air drag, there is only a vertical component of tension in the

balloon length. Since the balloon inclines with the air drag, a horizontal component of tension is present, which adds to the frictional drag on the traveller. This additional resisting force  $F_D$  is

$$F_D = T_{B2} \cos \theta_2 \quad 2.19$$

This force has been expressed by De Barr and Catling (1965) as

$$F_D = \frac{\mathbf{r}_A C_d d_y \mathbf{w}^2 H r_{\max}^3}{4R} \quad 2.20$$

With a good degree of approximation by assuming that  $\theta_1 = 90^\circ$ ,  $\cos \theta_1 = 0$ , then  $\theta_3 = 90^\circ - \theta_2$ ,  $\cos \theta_3 = \sin \theta_2$  and neglecting the traveller weight,

$$T_{B2} = \frac{a(\mathbf{m}_{RT} MR \mathbf{w}^2 + F_D \cos \mathbf{q}_4)}{\sin \mathbf{a} \cos \mathbf{q}_4 + \mathbf{m}_{RT} \cos \mathbf{a}}$$

$$\sin \mathbf{q}_4 = \frac{a \mathbf{m}_{RT} \sin \mathbf{q}_2}{\sin \mathbf{a} - a \cos \mathbf{q}_2} \quad 2.21$$

The balloon tension below the guide eye is

$$T_{B1} = \frac{a(\mathbf{m}_{RT} MR \mathbf{w}^2 + F_D \cos \mathbf{q}_4)}{\sin \mathbf{a} \cos \mathbf{q}_4 + \mathbf{m}_{RT} \cos \mathbf{a}} + \frac{1}{2} m R^2 \mathbf{w}^2 \quad 2.22$$

The spinning tension  $T_S$  can be computed as

$$T_S = \frac{\frac{\mathbf{m}_{RT} MR \mathbf{w}^2 + F_D \cos \mathbf{q}_4}{e^{\mathbf{m}_{RT} b_2} (\sin \mathbf{a} \cos \mathbf{q}_4 + \mathbf{m}_{RT} \cos \mathbf{a})} + \frac{1}{2} m R^2 \mathbf{w}^2}{e^{\mathbf{m}_{VL} b_1}} \quad 2.23$$

This expression for spinning tension shows that in addition to the variation of the angle of lead, the angles of wrap of the yarn around the traveller ( $\beta_2$ ) and the guide eye ( $\beta_1$ ) considerably influence the spinning tension. Both  $\beta_1$  and  $\beta_2$  vary from the beginning to the end of the cop build-up. In the case of a C-type traveller,  $a = 1/e^{\mu_{YT}\beta_2}$  and  $a$  varies from 0.55 to 0.62 as  $\sin \mathbf{a}$  varies from 0.5 to 0.95, from the top to the bottom of each chase, i.e. ring rail traverse. The angle between the yarn and the axis of the guide eye at the spinning region,  $\gamma$ , varies from  $15^\circ$  to  $30^\circ$  from the lowest to the topmost position of the guide eye. This alters the wrap angle of the yarn on the guide eye ( $\beta_1$ ). Further, the up-and-down movement of the ring rail affects continuously the wrap angle on the traveller. The values of yarn wrap angle over the guide eye fluctuate from zero to  $50^\circ$ , as the traveller moves towards the operator and moves away (towards the machine side). The parameter  $\beta_1$  can have at least four distinct values for every quarter-revolution of the traveller.

In the presence of air drag, the balloon tension increases and consequently

the value  $P$  increases and hence the possibility of having  $H/P > \mathbf{p}$  forming multiple nodes decreases. In the presence of air drag, the horizontal component of the yarn balloon tension increases from the guide eye to the traveller and the balloon deviates progressively from the axial plane. The work done by the rotating yarn balloon per revolution is the product of the tangential component of balloon tension and the circumference of the radial path of the balloon; as  $(T_{B2} \cos\theta_2)(2\mathbf{p}r) \neq 0$ , neither of them could be zero. With a finite radius for the balloon ( $r > 0$ ), the balloon portion could never be at the axis of the balloon. As a result, the balloon forming the nodes (as seen in Fig. 2.11) is not possible. The balloon can form necks as depicted in Fig. 2.13.

*Balloon collapse*

Balloon collapse is likely to occur when the neck of the balloon contacts the bobbin, resulting in a yarn break. Balloon collapse occurs most likely with the longest balloon at the beginning of the cop build-up. Having a smaller lift (from the ring to the guide eye) and ring radius are useful to avoid balloon collapse. Reducing the spindle speed and increasing the yarn tension by using a heavier traveller improves the value  $P$  and reduces the probability of balloon collapse. However, a compromise has to be made between spinning productivity and increased yarn breakage rate, owing to the increased spinning tension. The ratio of balloon height to ring diameter should therefore be kept  $\leq 5.2$  and a balloon control ring placed above the



2.13 Balloon with neck formation.

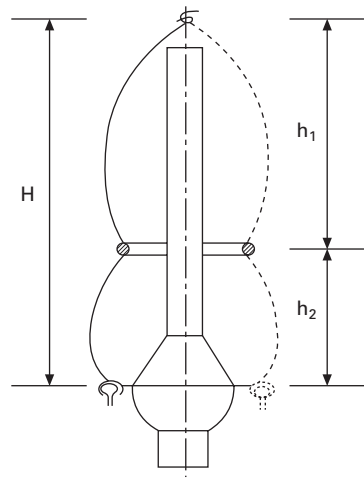

2.14 Balloon control ring dividing a large balloon into two halves.

ring rail, a little below the midpoint between the guide eye and the ring. The balloon control ring divides the balloon into sub-balloons of height  $h_1$  and  $h_2$  such that both  $h_1$  and  $h_2 < H$ , avoiding the likelihood of balloon collapse albeit the overall balloon height could be increased (Fig. 2.14). It restricts the balloon radius, reduces the air drag on the balloon, and lowers the yarn tension and hence the end breaks.

### 2.5.5 Practical spinning tension variation

The study of spinning tension has been the subject of a number of investigations (Stalder, 1991, 1994; Lünenschloß and Bünger, 1984; Sonntag, 1993, 1994; Azarschab, 1995). The amplitude and frequency of the tension fluctuations in the winding zone are higher than those in the spinning zone (Lünenschloß and Bünger, 1984). The spinning tension increases with the increase in traveller speed and ring-traveller frictional force. An eccentric yarn guide does not change the average spinning tension significantly but the tension distribution becomes wider and peak tension increases. A cross-correlation has been found between the spindle vibration and the spinning tension (Sonntag, 1993, 1994). It is reported that the spinning tension is a function of spindle speed, traveller mass, ring diameter, coefficient of friction between ring and traveller, and angle of lead (Stalder, 1991, 1994).

An example of the variation in spinning tension, from the beginning to the end of the cop build, is shown in Fig. 2.15. It can be seen that the average spinning tension is highest at the base of the cop and declines during the course of the cop build. There are two reasons for this. First, when winding the yarn at the base of the cop, the balloon will be at its longest length. The air drag forces acting on this length will therefore induce the highest balloon tension. Secondly, due to the dynamic loading of the yarn during spinning, tension amplitudes from the winding and balloon regions are transmitted to the spinning region and result in a high spinning tension.

The CV% of spinning tensions at different positions of cop build are 18.7%, 23.1% and 24.5% at the bottom, middle and top positions of the cop respectively (Rengasamy *et al.*, 2004). The higher CV% of the spinning

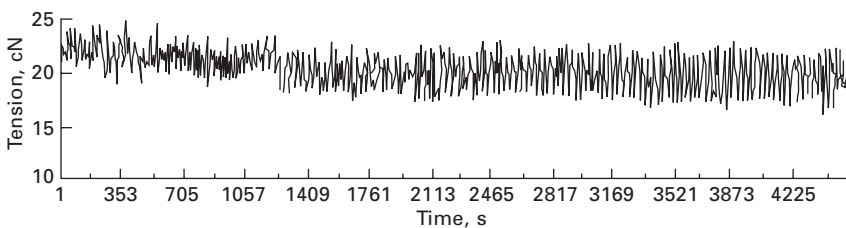

2.15 Spinning tension variation from beginning to end of cop.

tension at the end position of the cop build can be attributed to two factors. A statically balanced spindle (the spindle axis and the principal mass axis coinciding) may develop quasi-static imbalances as the yarn is wound over the bobbin. At any instant while winding the yarn on the bobbin, the mass distribution around the spindle axis is never uniform. This shifts the principal mass axis of the spindle–bobbin unit continuously with the presence of excess mass always at one side of the spindle. When more and more yarn is wound from the base to the top of the bobbin, the mass distribution around the spindle axis becomes more uneven. This leads to more vibration in the rotating spindle, resulting in high fluctuations in the spinning tension. Further, while winding the yarn onto the top of the bobbin, the size of the balloon is small. With this shorter yarn length in the balloon region, the damping of the vibrations transmitted from the winding region is less effective, as the ballooning yarn has less energy of absorption and hence causes transfer of more tension fluctuations to the spinning zone.

The variations in spinning tension for a full traverse of ring rail movement are given in Figs 2.16 (damped) and 2.17. A progressive decrease in spinning tension is observed while the ring rail moves downward. The spinning tension approaches the peak value at the top position of the ring-rail movement. This can be attributed to the progressive decrease in the angle of lead and the transfer of more yarn from the balloon region to be wound onto the bobbin as the ring-rail traverses upwards. The following equations apply to the rail movement. For upward motion of the ring rail,

$$N_s - N_t = \frac{V_F + V_R}{\rho D_B} \tag{2.24}$$

$$N_t = N_s - \frac{V_F + V_R}{\rho D_B} \tag{2.25}$$

For downward motion of the ring rail,

$$N_s - N_t = \frac{V_F - V_R}{\rho D_B} \tag{2.26}$$

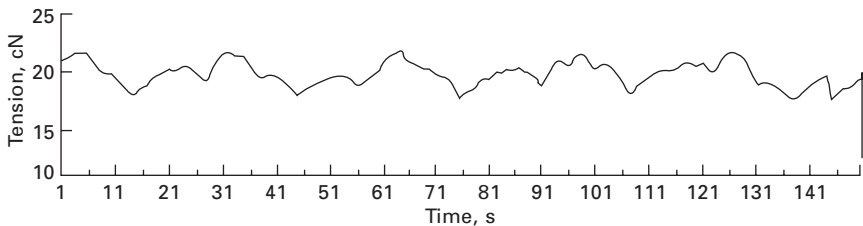

2.16 Spinning tension variation for a traverse of ring rail.

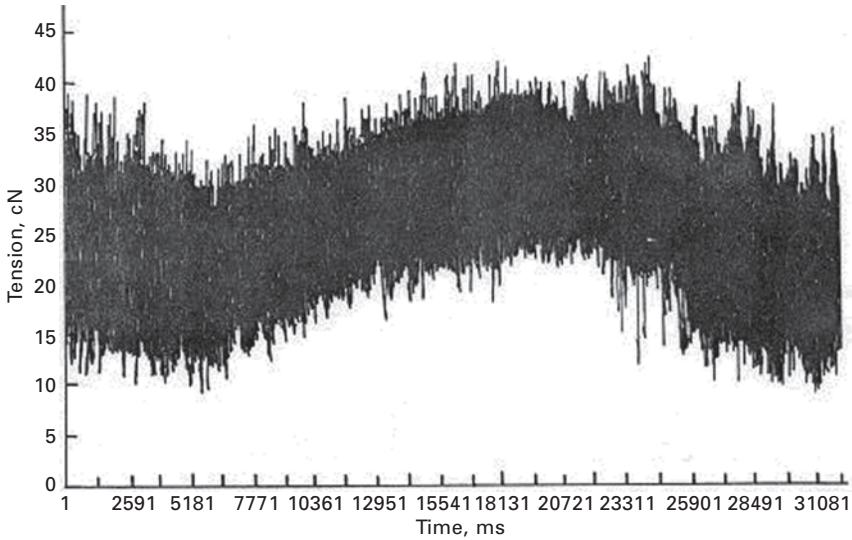

2.17 Spinning tension variation for a traverse of ring rail, damped.

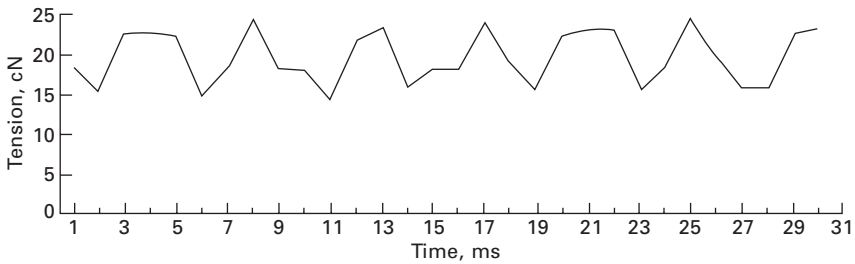

2.18 Spinning tension fluctuations in milliseconds.

Hence during upward motion of the ring rail, the traveller speed decreases, signifying increased frictional drag on the traveller and yarn tension, and the reverse is the case for downward motion of the ring rail.

It is also observed from Figs 2.16 and 2.17 that the time required to obtain the lower minima from the higher maxima of the spinning tension is half of that required to reach the maxima from the minima. This is due to the faster traverse of the ring rail during downward movement than during upward movement.

The spinning tension measured at 1 ms response time is given in Fig. 2.18 with a spindle speed of 16,500 rpm corresponding to a time of 3.6 ms for one revolution of the traveller. It is observed that, on average, for every 4 ms one peak is generated, which implies that each revolution of the traveller produces at least one peak value of the spinning tension. In fact, in each rotation of the traveller, there are five peak tensions (De Barr and

Catling, 1965). The observation of only one tension peak in each rotation of the traveller is due to the limitation of response time of the measuring system. For each revolution of the traveller the angle of wrap of the yarn over the guide eye ( $\beta_1$ ) changes periodically (Fig. 2.19).

The angle of contact is low while the traveller moves away from the machine (towards the operator) and it is high when the traveller moves towards the machine. The periodic change of this angle influences the transfer of tension amplitudes from the winding zone to the spinning zone, resulting in fluctuations in the spinning tension.

### 2.5.6 End breaks in ring spinning and spinning tension variation

The end breakage rate is an important parameter which determines the productivity and yarn quality. The weakest part of a forming yarn is the spinning triangle below the front drafting rollers. Most end breakages occur there. The end breakage phenomenon in this region is based on fibre slippage;

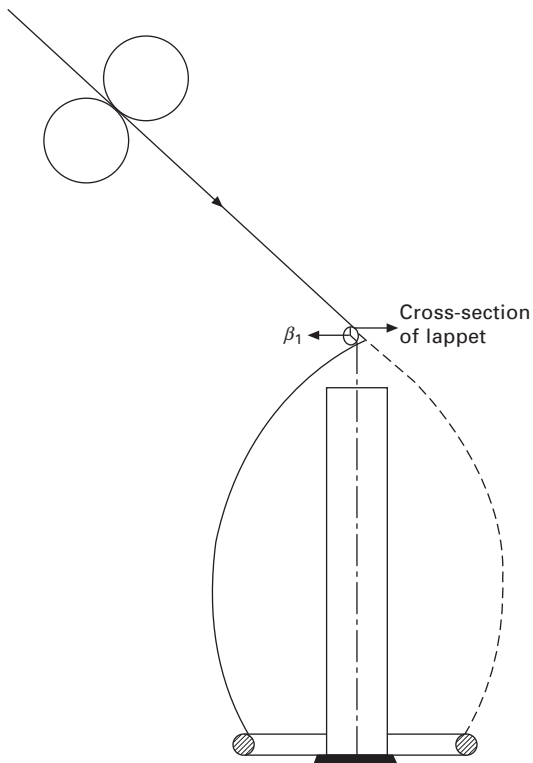

2.19 Angle of wrap of yarn over the lappet.

there is no evidence of fibre breakage. At the spinning triangle the fibre ribbon is in a partially twisted state. The force required to break the forming yarn in this partially twisted state is actually the force required to pull out the twist insertion point away from the front rollers; this is somewhat greater than about one-third of the single thread strength (De Barr and Catling, 1965). Three important factors therefore govern the end breakage rate: (1) the number of fibres in the triangle and the variation of this number as subsequently new ribbon length forms the spinning triangle, (2) the ease of twist propagation to the apex of the triangle, and (3) the mean yarn tension and tension fluctuation.

### *Mechanism of end breakage in ring spinning*

It may be assumed that the yarn is composed of a series of successively linked fibre bundles. The length of any given link is poorly defined, because the elements of the fibre bundle are not separate entities but each gradually merges into its neighbour at either end. The links may therefore be taken as the mean overlap of fibre ends. Therefore an average element length may be considered to exist. For carded cotton yarns the average length of the link is approximately 3 mm (Lord, 1961). The yarn breaks are governed by the weakest link, which is about one-third of the yarn strength (Peirce, 1926). The strengths of the links of the fibre bundle just issuing from the front rollers are independent variables and follow a normal distribution, i.e., a link of maximum strength may follow immediately one of minimum strength. The strength is constant within a link but varies from link to link. The strength of this link is proportional to the number of fibres forming the link. The coefficient of variation of the strength of this link is equal to the coefficient of variation of mass per unit length of the yarn (Ghosh *et al.*, 2004). The total number of links moving from the nip of the front rollers per revolution of the traveller,  $n$ , is given by

$$n = \frac{V_F}{\bar{l}_h N_t} \times 10^3 \quad 2.27$$

where  $V_F$  = front roller delivery speed in m/min, and  $\bar{l}_h$  = average length of the links of fibre bundles, i.e. 3 mm.

Assuming that  $P$  is the probability of the number of weak links just emerging from the nip of the front rollers causing an end to break, then the number of end breaks per spindle rotation ( $B$ ) is given by the following equation:

$$B = nP \quad 2.28$$

Now, the strengths ( $x$ ) of the links of fibre bundle issuing from the front

rollers follow a normal distribution  $N(\mu, \sigma^2)$  with mean  $\mu$  and variance  $\sigma^2$  (Fig. 2.20). The standard deviation  $\sigma$  is then

$$s = \frac{Vm}{100} \tag{2.29}$$

where  $V$  = the coefficient of variation of mass per unit length of yarn.

The variations of spinning tension in ring spinning are mainly caused by the instability in the rotation of the the traveller. It is an established fact that in each rotation of the traveller there are five peak spinning tensions. For an end to break, the peak of spinning tensions is a more decisive factor than the average value. Let the mean of the peak values of spinning tensions be  $T$ . The average time taken in milliseconds to pass a link through the nip of the front rollers can be calculated as

$$t_1 = \frac{\bar{l}_h}{V_F} \times 60 \tag{2.30}$$

During spinning, the average time taken for a rotation of the traveller is  $t_2 < t_1$ . Thus each link experiences at least several peak spinning tensions. A yarn break will occur when  $T$  is greater than the strength of a link just passing from the front roller. Therefore, the strength of the links, which are lower than  $T$ , would lie at a distance of  $Z\sigma$  from the left side of  $\mu$  in the normal distribution curve, where,  $Z$  is the standard normal variate.

A linear transformation of the normal distribution  $N(\mu, \sigma^2)$  into the standard normal distribution  $N(0,1)$  is obtained by (Ghosh *et al.*, 2004)

$$z = \frac{x - m}{s} \tag{2.31}$$

The probability, when  $T$  is greater than the strength of the links just passing from the nip of the front rollers, can be found by the relationship

$$P = 1 - \Phi(Z) \tag{2.32}$$

where  $\Phi(Z)$  can be expressed as

$$F(Z) = \int_z^\infty e^{-z^2/2} dz \tag{2.33}$$

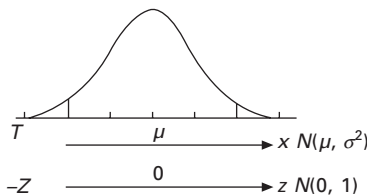

2.20 Distribution of strength of fibre bundles.

To test the validity of the above mechanism, 30 tex carded cotton yarns were produced at a spindle speed of 16,500 rpm and a yarn delivery speed of 20 m/min (Ghosh *et al.*, 2004). The spinning tension was measured using a Rothschild tensiometer-2000 with a frequency of 1000 Hz (the response time is 1 ms). Thus it was possible to observe only one peak of the spinning tension in one revolution of the traveller instead of the four or more peaks that usually occur. The time scales are  $t_1 = 9$  ms and  $t_2 = 3.6$  ms. The measured strength of the yarn is 375 cN, which indicates that the mean breaking force of the link is 125 cN. The measured peak spinning tension is  $> 40$  cN. When the strengths of the links follow a normal distribution the standard deviation value,  $\sigma$ , with measured  $V = 13.1\%$ , would be 16.34 cN. For a break to occur (i.e. the strength of the links being lower than the value of the peak spinning tension), the standard normal variate ( $Z$ ) would equal 5.2. Therefore, to fulfil the condition of end breaks, the strength of the links  $x$  that are lower than the value of the peak spinning tension would lie at a distance of  $5.2\sigma$  from the left side of the mean ( $\mu$ ) in the normal distribution curve, i.e.  $x = 125 - 85 = 40$  cN. Thus using Equations 2.32 and 2.33 the probability ( $P$ ) of the strength of the links being lower than the mean value of the peak tension is  $1 \times 10^{-7}$ , which means that one link out of  $10^7$  links is the weakest one that causes an end to break within a particular spindle.

It is logical to assume that thin places emerging out of the front drafting rollers are the potential sources of end breaks. Thin places undergo overtwisting due to their lower rigidity, and hence are the weakest. The strength of fibre links also depends on the grip exercised by the top front roller over the lower roller, since poor gripping leads to slippage of the fibre link itself, and consequently to end break. A higher force on the top roller and the use of softer top front roller coverings enhance the grip of the fibres. A reduction in friction between the ring and the traveller reduces the mean spinning tension. The sources of peak tensions are the vibration of the machine elements – main shaft, pulleys, spindle and traveller instability – which are superimposed on the basic tension. Of these, the spindle and traveller contribute more to the vibrations. The spindle is one of the most unbalanced rotating parts where it is supported at its bottom and hip, leaving its tip to oscillate. The spindle always experiences dynamic imbalance due to the variation of yarn mass on the bobbin in the radial and axial directions (with tapered cop build-up). This is converted into traveller speed variations. Further, the up-and-down ring rail movement and its association with the change of yarn length to be wound and balloon size result in variation of the tilt and friction drag on the traveller; hence the traveller continuously experiences acceleration and deceleration. All these lead to high-frequency tension fluctuation with variable amplitude to the winding tension that are transferred to the spinning region, causing end breaks. There is no design solution in sight to alleviate this. Typical end break rates for a cop build-up are shown in Fig. 2.21. The

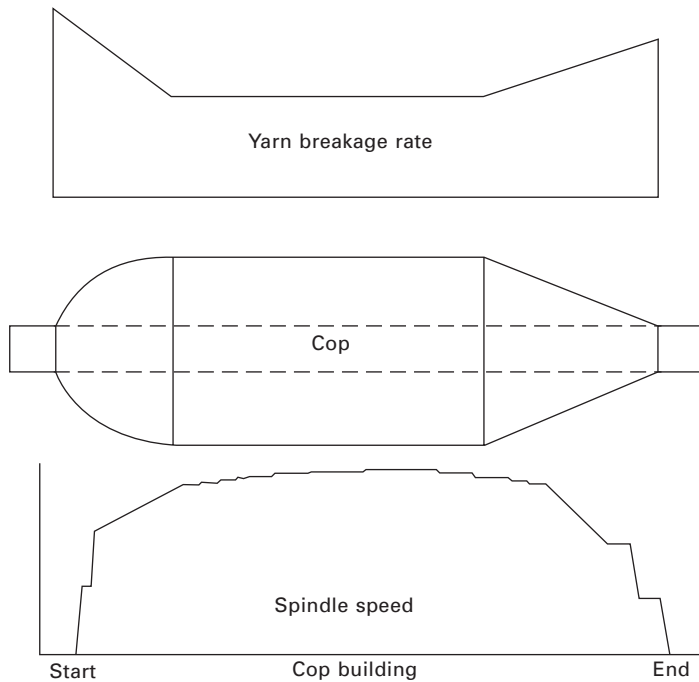

2.21 Yarn breakage rate and control of spinning speed.

practical approach to reducing end breaks is to control the spindle speed from the start to the end of the cop build, so that the spinning tensions and peak tensions on the yarn are kept as low as possible. Reducing the traveller weight also helps to some extent to control end breaks, provided it does not lead to balloon instability.

### 2.5.7 Package formation and sizes

The winding of yarn in ring spinning is complex. The yarn is wound in layers along the length of a tapered plastic bobbin, mounted on the spindle, the action of which is termed 'cop building'. This layering of the yarn enables it to be easily unwound without slough-off and with undue tension variations during high-speed yarn rewinding. The point of lay of yarn on the bobbin is periodically moved up and down by the motion of the ring rail, and after each cycle (one chase), the bottom-most point of yarn lay is shifted upwards a little by means of a step in height of the start position of the ring rail's periodic motion. The wound bobbin or 'cop' has three distinct parts: a lower curved base, a cylinder in the middle, and a conical tip. While forming the base of the cop, the upward shift of the ring rail at the bottom of the chase is kept low, giving a shorter traverse. Since the length of yarn delivered during

each traverse stroke is the same, the volume per layer is increased, thereby generating the curvature (Fig. 2.21). The average speed of traverse of the ring rail is slower during its upward stroke than during its downward stroke. The slow traverse of the rail during its upward stroke helps in laying more coils of yarn, i.e. with short pitch. These coils are called 'winding coils'. Since the bobbin is tapered with its diameter reducing from the bottom to the top, the winding rpm must increase from the bottom to the top. This leads to a progressive decrease in the pitch of the coils or an increasing package density from the bottom to the top. In order to maintain a constant package density, the ring rail is accelerated during its upward motion. For the same reason, the ring rail decelerates during its downward stroke. The yarn coils laid during the downward stroke are 'binding coils' with long pitch.

The winding and binding coils are considered to be screws of opposite hands. This method of layering the coils provides poor frictional contacts between these two types of coils yet higher frictional contacts within winding coils. As a result, during unwinding the cop, the likelihood of yarn slough-off is reduced.

The cop size in ring spinning is very much limited both by the size of the ring and by the permissible balloon height. The ring diameter varies from 41 to 51 mm and the lift (length of the bobbin over which yarn is wound or ring rail traverses) from 175 to 205 mm. The ratio of lift to ring diameter is around 4 to 4.7. Since the yarn tension is inversely proportional to  $\sin\alpha$ , i.e.  $R_B/R$ , reducing the bobbin diameter below the ring radius leads to excessive tension on the yarn and end breaks. The maximum yarn content in the cop is around 60 to 110 g, which necessitates frequent stops of the machine for doffing the package. Increases in package height and diameter above the values indicated would result in uncontrollable yarn tensions and excessive power consumption, as the power to rotate the package is proportional to the ring diameter to the power 2.75.

## 2.6 Post-spinning

Ring spun yarns wound on the bobbins are not suitable to be employed directly in weaving and knitting as these processes require large-sized packages. Yarns should be rewound onto a large package in a separate post-spinning operation and any faults in the yarn removed and the cut ends joined by splicing (Lawrence, 2003; Lord, 2003). The production of yarns for heavy-duty applications such as sewing threads, cords, cables and ropes requires assembling two or more to produce the required linear density yarns. This is achieved by twisting two or more yarns together. To reduce warp breakages in the weaving of worsted fabrics, two yarns of the same count are twisted together. This process is called doubling or plying and the resulting plied or doubled yarn has sufficient abrasion resistance to withstand the weaving

process and so dispenses with the need for applying a size coating to the individual, constituent yarns, i.e. the singles yarn. Yarn rewinding together with fault clearing and doubling/ply-twisting are the operations that constitute post-spinning operations on spun yarns.

### 2.6.1 Yarn rewinding and fault clearing

The low yarn content of the ring cop requires combining several of them to make a larger package of around 2 kg in the yarn rewinding operation, suitable for high-speed warping. Further, yarn faults must be removed in the yarn winding operation so the yarn can withstand the stresses that are imposed during warping, weaving and knitting processes. With high-speed winding at up to 1200 m/min and the use of electronic yarn clearers, the machine efficiency in winding is not affected much by the sizes of current ring cops.

### 2.6.2 Ply-twisting

Ply-twisting is the process of combining two or more yarns by twisting them together. Twisting of two or three or more yarns (2-ply, 3-ply, etc.) in an assembled form is performed either on a down-twister/ring-twister or on a two-for-one twisting machine. The ring twisting machine consists of feed rollers, thread guide eye, ring, traveller, traversing ring rail and spindle with bobbin similar to those found on a ring spinning machine (Fig. 2.22). The supply yarns from individual packages are withdrawn by feed rollers and pass through the guide eye, then underneath the traveller and finally to the bobbin. The principle of twist insertion is identical to that in ring spinning. The tension in all the single yarns should be the same to avoid the low-tension yarn spirally wrapping the high-tension component. Yarns to be plied can also be wound together under controlled conditions into a large-sized package in a separate operation. This large package becomes the feed material to the ring twisting machine or the two-for-one twisting machine.

The single yarns are mostly spun with Z-twist and during plying S-twists are inserted (the exception is sewing threads which have an S-Z combination). The single yarns undergo untwisting and are twisted together with respect to the ply yarn axis. The ratio of ply to single twist is usually kept at 0.6–0.67. The surface fibres on the single yarn become straightened whereas the fibres at their axes become more oblique. The surface fibres protruding as hairs are entrapped during plying and contribute to strength of the plied yarn. Further, the evenness of plied yarn is better than that of a single yarn of the same count, due to statistical phenomena and the frictional support provided by one yarn to thin places on the other.

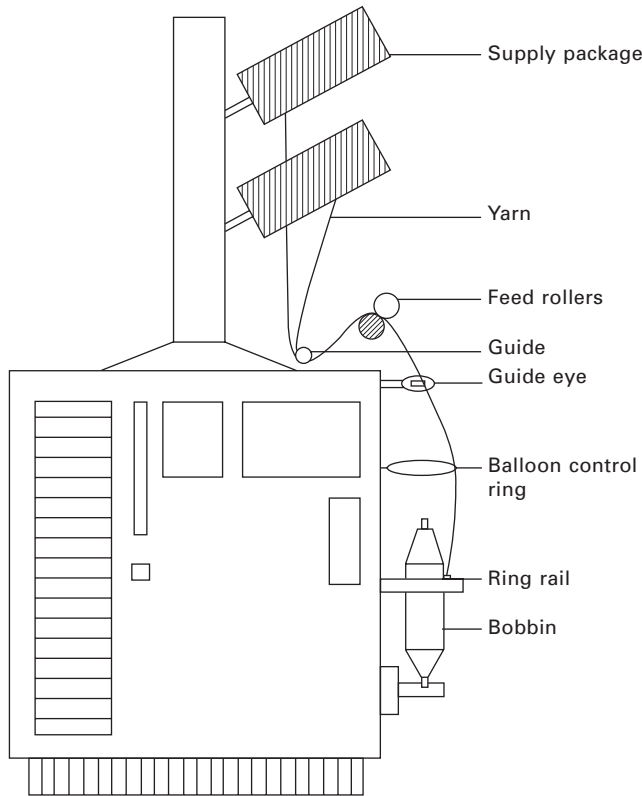

2.22 Ring twisting machine.

### *Two-for-one twister*

The assembled yarn package having the required number of single yarns is kept stationary on a rotating spindle. Yarn from the package passes through a yarn guide mounted on freely rotating arms and through the axis of a hollow rotating spindle, at the base of which it passes through an eyelet and on to the winding head (Fig. 2.23). Each rotation of the spindle simultaneously inserts two turns of twist to the yarn: one turn of twist in the length of yarn inside the spindle, and another turn of twist in the length of yarn between the eyelet and the take-up rollers by forming a revolving yarn balloon.

## 2.7 Applications of ring spinning

Classical ring spinning is widely used to convert a wide range of short-staple fibres and long-staple fibres into yarns (Table 2.2). Ring spinning of bio-synthetic fibres such as PLA fibres is also of growing interest (Ingeo Technical Bulletin, 2005). Many derivatives of ring spinning systems produce

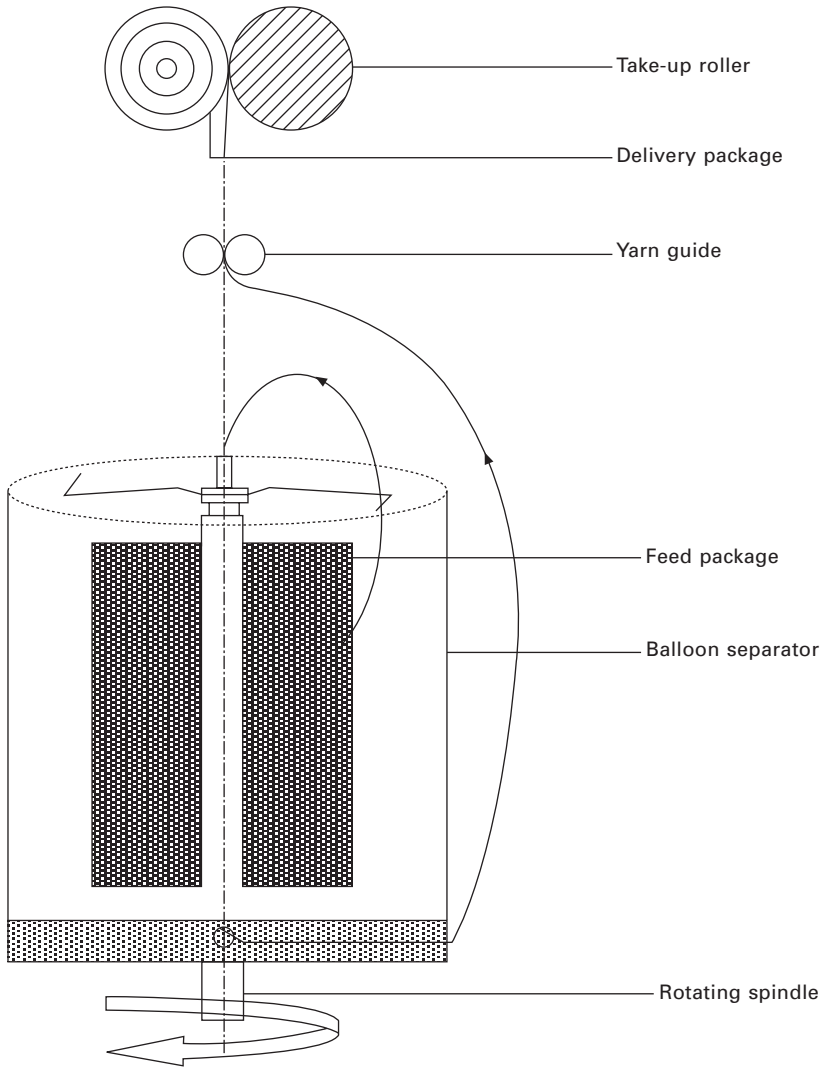

2.23 Mechanism of two-for-one twisting.

distinct yarns to cater for different applications (Table 2.2). In the case of the long-staple sector, the spun-plied spinning systems produce wool-based plied yarns with low hairiness requiring no doubling and plying operations.

The single yarns intended for core-spun sewing threads such as polyester/cotton and polyester/polyester are produced using ring spinning by having an attachment on the creel of the ring spinning machine that feeds high tenacity polyester filaments into the nip of the front rollers. Stretch-to-fit garments require yarns of high stretch with elastic recovery. Feeding of elastic

Table 2.2 Applications of ring spinning

Range of fibres		
Short staple	Long staple	Derivatives of ring spinning
Cotton, regenerated, polyester and blends	Wool, polyester, acrylic, Nomex, Kevlar and blends	Core spinning (hard and elastic core), spun-plied spinning (double rove spinning, solo spinning), compact spinning systems

filaments directly into the nip of the front roller under controlled stretch is achieved by retrofitting an elastic core attachment to the creel of the ring spinning machine. Commercialisation of compaction fibre strand has opened new avenues to produce less hairy cotton yarns with moderately improved strength and evenness. The compact yarns pick up less size and encounter fewer breaks during rewinding, leading to cost savings. Fabrics made from these yarns exhibit enhanced print clarity.

## 2.8 Future trends

Classical ring spinning has so far been able to withstand the competition from other spinning systems largely because of its inherent advantage of producing yarns with high strength and a wide range of yarn counts from a wide range of fibre types. Its production speed is currently limited to 25 m/min, in spite of developments in designing new ring and traveller combinations. Improving productivity beyond this level requires crossing three hurdles. The first is traveller burn. With the sliding traveller motion, the limiting traveller speed is less than 50 m/s. A major technological breakthrough to operate travellers at higher speeds would be possible only if the mode of friction could be changed to rolling friction. A rolling traveller might solve this problem with less frictional drag.

A review of the research activities on the metallurgical and design aspects of rings and travellers and their pace of outcome does not indicate any foreseeable future innovations that will produce a quantum jump in traveller speed. Rotating rings based on magnetic fields are unlikely to be commercialised owing to their high cost, requirement for a large spindle gauge, high noise level, the need for regulating the start-up and shut-down speeds, and the requirement of a special roving brake device to prevent material waste during yarn breaks and piecing up. If the ring spinning system could be developed to overcome the first obstacle, it would need a spindle that could operate beyond 30,000 rpm. The ring spindle is one of the least dynamically balanced rotating devices. To operate at high speeds above 30,000 rpm with negligible vibrations requires advanced engineering. The problem does not end with the development of high speed spindles. The difficulty arises due

to the fact that twisting and a complex yarn winding method are combined in one action that has to be accomplished by the traveller. The traveller has also to perform a delicate balancing task between maintaining the balloon stability and reduced yarn tension. There is a minimum traveller mass needed to maintain balloon stability which also generates the yarn tension and consequently the potential for yarn breaks and loss of productivity. With increasing spindle speed the yarn tension increases rapidly and the control of yarn breaks becomes a very difficult task.

Notwithstanding these obstacles that stand in the way of improving the productivity of ring spinning, classical ring spinning will continue to dominate the spun yarn market at least in the near future, as there are no foreseeable developments in other spinning technologies that can provide the production of high strength yarns over a wide count range from a wide range of fibre types. It is reasonable, however, to forecast possible developments of new variants of the ring spinning system, since a number of them already have been successful, namely core spinning, compact spinning and spun plied spinning.

## 2.9 References and bibliography

- Azarschab, M. (1995) *Melliand Textilber.*, 76, E240.
- Bracker (2008) [www.Bracker.com](http://www.Bracker.com), Short staple spinning manual, April 2008.
- Broughton, M., Mogahzy, Y. E. and Hall, D. M. (1992) 'Mechanism of yarn failure', *Text. Res. J.*, 62, 131–134.
- De Barr, A. E. and Catling, H. (1965) *The Principles and Theory of Ring Spinning*, The Textile Institute, Manchester, and Butterworths, London.
- Ghosh, A., Ishtiaque, S., Rengasamy, S. and Patnaik, A. (2004) 'The mechanism of end breakage in ring spinning: a statistical model to predict the end break in ring spinning', *AUTEX Res. J.*, 4(1), 19–24.
- Hori, Y. (1955) 'A statistical analysis of yarn breakage rates on a spinning frame', *J. Textile Mach. Soc. Jpn.*, 8(2), 54–59.
- Huang, X. C. and Oxenham, W. (1994) Predicting end breakage rates in worsted spinning, Part I: Measuring dynamic yarn strength and tension', *Text. Res. J.*, 64(11), 619–626.
- Huang, X. C., Oxenham, W. and Grosberg, P. (1994) 'Predicting end breakage rates in worsted spinning, Part II: A new model for end break prediction', *Text. Res. J.*, 64(12), 717–722.
- Ingeo Technical Bulletin, 341104, [www.natureworkslc.com/p](http://www.natureworkslc.com/p) (2005).
- Kawakami, J. and Hasimoto, M. (1955) 'Theoretical estimation of end breakage rate in spinning', *J. Textile Mach. Soc. Jpn.*, 27(1), 1–7.
- Klein, W. (1993) *Manual of Textile Technology: The Technology of Short-staple Spinning*, Short-staple Spinning Series, edited by H. Stalder, Vols 1 to 5, The Textile Institute, Manchester.
- Lawrence, C. A. (2003) *Fundamentals of Spun Yarn Technology*, CRC Press, New York.
- Lord, E. (1961) 'The characteristics of raw cotton', in *Manual of Cotton Spinning*, Volume II, Part I, p. 232, The Textile Institute, Manchester.

- Lord, P. R. (2003) *Hand Book of Yarn Production: Technology, Science and Economics*, The Textile Institute, Manchester, p. 235.
- Lünenschlob, J. and Bünger, C. M. (1984) *Melliand Textilber.*, 65, 297, E277.
- Morton, W. E. (1956) 'The arrangement of fibres in single yarns', *Text. Res. J.*, 26(5), 325–331.
- Peirce, F. T. (1926) 'Tensile tests for cotton yarns, Part V: The weakest link theorems on the strength of long and composite specimens', *J. Text. Inst.*, 17, T355–T368.
- Rengasamy, R. S., Ishtiaque, S. M., Ghosh, A., Patnaik, A. and Bharati, M. (2004) 'An analysis of spinning tension in ring spinning', *Indian J. Fibre Text. Res.*, 29, 440–442.
- Salhotra, K. R. (2002) 'Mechanism of end breakage in ring spinning', in *Advances in Technology of Yarn Production*, edited by R. Chattopadhyay, NCUTE, IIT Delhi.
- Sonntag, E. (1993) *Melliand Textilber.*, 74, E402.
- Sonntag, E. (1994) *Melliand Textilber.*, 75, 350, E87.
- Stalder, H. (1991) *Melliand Textilber.*, 72, E245.
- Stalder, H. (1994) *Melliand Textilber.*, 75, 570, E140.
- Vijaya kumar (2003) [www.geocities.com/vijayakumar\\_777/processparspinning.html](http://www.geocities.com/vijayakumar_777/processparspinning.html) (2003).
- Wang, X., Huang, W. and Huang, X. B. (1999) 'A study on the formation of yarn hairiness', *J. Text. Inst.*, 90(4), 555–569.

## Fundamental principles of open end yarn spinning

A. DAS and R. ALAGIRUSAMY, IIT Delhi, India

**Abstract:** Open end spinning has several advantages over ring spinning, such as increased production rate, separation of twisting and winding, possibilities of full automation of yarn spinning, and elimination of speed frame and winding. Rotor spinning, friction spinning and vortex spinning systems are three major methods of yarn manufacture developed on the principle of open end spinning. Rotor spun yarns have a different structure: a densely packed core of fibres substantially aligned with the yarn axis; loosely packed fibres twisted around the core at a considerable angle to the axis; and wrapper fibres on the outside. Due to this type of structure, open end (OE) spun yarns are successful in the commercial manufacture of coarser yarns. The structure of friction spun yarn is determined by the way fibres are assembled into the yarn. The structures of OE-friction spun yarn and core-type friction spun yarns are different. The internal structure of open end friction spun yarn is characterized by the inferior fibre orientation, buckled and folded fibre configurations and loose packing of fibres associated with low tensions during yarn formation. Vortex yarn has a fasciated yarn structure. The yarn has a two-part structure: core and wrapper fibres. The parallel core fibres are wrapped by the surface fibres to impart strength. The principle and methods of manufacturing of these open end spun yarns, their properties and end uses are discussed in detail.

**Key words:** air jet, fibre, fibre transport, friction spinning, friction drum, nozzle, opening roller, rotor spinning, vortex spinning, wrapper fibre, yarn, yarn structure.

### 3.1 Introduction

The industrial revolution which began in the eighteenth century produced many important innovations in the textile industry. Those related to the spinning of fibres are listed below [1]:

- 1764: James Hargreaves invented the ‘spinning jenny’.
- 1769: Richard Arkwright invented the water-powered spinning frame.
- 1779: Samuel Crompton combined the two systems in his ‘spinning mule’.
- 1828: Thorpe, Jenk and Mason created the prototype ‘ring frame’.

The twist insertion mechanism which requires one full rotation of the yarn bobbin to introduce one turn of twist into the yarn is one of the main reasons

for limiting the productivity of ring spinning. Increasing the spindle speed, and thereby the bobbin speed, increases productivity but the increase in spindle speed is itself limited owing to the heat transfer and wear problems of the traveller situated on the ring. The upper limit of the traveller speed in mill conditions is 35 m/s. Open end spinning methods overcome these problems of ring spinning by separating twisting and winding. Open end spinning enables substantial increases in productivity and the possibility of full automation of the spinning process.

Open end spinning is also known as break spinning or free fibre spinning. In this process the fibrous material is highly drafted to separate out the individual fibres. The individual fibres are subsequently collected onto the open end of the yarn. This is rotated to twist the fibre into the yarn structure to form a continuous strand of yarn. This is wound onto a bobbin to form the yarn package. The twisting action occurs simultaneously with but separately from the winding action, unlike ring spinning where twisting and winding actions occur together. Figure 3.1 shows a flowchart of the open end spinning method.

To produce an open end yarn, it is necessary to use a very high draft so that the fibre flow is reduced to just a few fibres in the cross-section. This prevents twist from running back into the fibre to produce a false twist. A sliver might have about 20,000 fibres in the cross-section. If the fibre flux just before the open end is 2, the initial draft is 10,000:1 [2]. It is not possible to use conventional roller drafting to produce such very high drafts. It is more normal to use a toothed roller, which acts in much the same way as the licker-in of a carding machine. This high drafting of slivers by a saw-tooth covered roller is called opening, and the roller is termed an opening roller. During opening, slivers are also cleaned by freeing and removing foreign particles.

The essential features of the open end spinning process are thus drafting, fibre transport, fibre alignment, cleaning (if necessary), fibre condensation, twisting, yarn removal and winding [3]. An open end spinning system comprises a device for drafting the fibrous mass into individual fibres, a means of transporting the fibres to the yarn end, a device for collecting the separated fibres onto the yarn end in a manner that enables the correct yarn

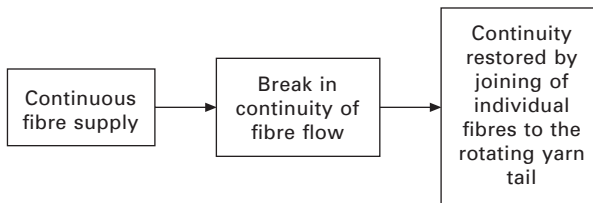

3.1 Block diagram of process flow in open end spinning.

count to be obtained, a device for rotating the yarn end to insert twist into the collected fibres, and a means of winding the yarn onto the package [4].

Open end spinning has the following advantages:

- Lower power consumption per unit quantity of yarn produced
- Higher speed of twist insertion resulting in very high yarn delivery speed
- A significant resulting increase in productivity
- Larger delivered package size
- Elimination of some processes such as roving and winding
- More uniform yarns.

Since fibres have some freedom of movement during twist insertion, the outer fibres tend to slip more than the core fibres. Consequently, unlike ring spun yarns, open end yarns consist of a three-part structure: a densely packed core consisting of about 80% of the fibres substantially aligned with the yarn axis; loosely packed fibres twisted around the core at an angle to the axis; and wrapper fibres on the outside. In a ring spun yarn, nearly all the fibres migrate. The lower incidence of fibre migration in open end yarns along with the reduced fibre extent contributes to lower yarn strength but greater uniformity in appearance and a more even surface [5].

Open end yarns produce different characteristics in the end product. These yarns may be used to advantage in fabrics where uniformity and a smoother surface are of prime importance. Open end yarns are used in pile fabrics, apparel, household, industrial and technical applications [1, 6]. Uses include heavyweight satin and poplins, corduroy, velveteen, rainwear, denims, drills, sheets, pillow cases, bed spreads, printed fabrics, curtains, window blinds, upholstery, cleaning cloths, dress goods, underwear, rugs, carpets, blankets, terry towels and diapers.

### **3.2 Commercial open end spinning systems: rotor spinning**

Three open end spinning systems have been developed: rotor spinning, friction spinning and vortex spinning. Rotor and friction spinning have achieved commercial success whilst the vortex system has the promise to become commercially successful in the near future [7].

The general principle of open end rotor spinning is shown in Fig. 3.2. The input sliver is first opened and drafted by the opening roller. The fibres are transported via a tube to the rotor where the fibre strand is subjected to twist insertion. After twisting, the output yarn is then wound into 'cheese' or 'cone' packages of the required size.

The input sliver can be a carded or drawn sliver. Generally a drawn sliver is used. The sliver is pulled through a condenser by a feed roller, operating

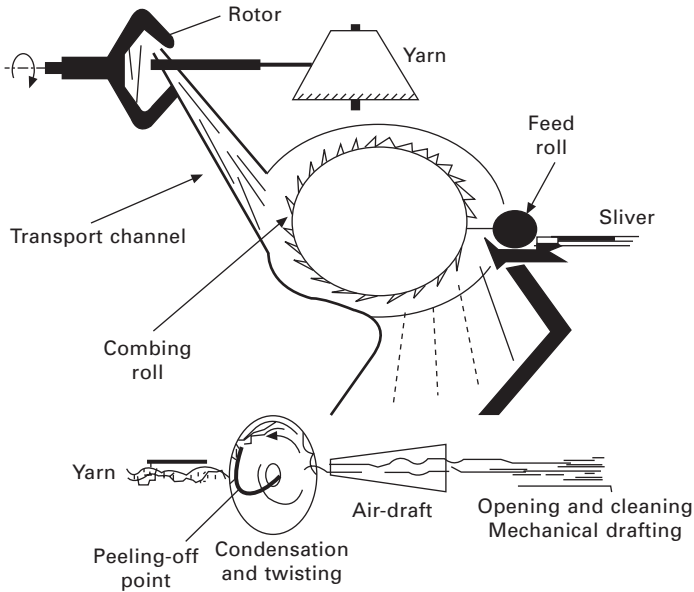

3.2 Principle of open end rotor spinning.

in conjunction with a spring-loaded feed pedal. The nip point between feed roller and feed pedal determines the position of fibre bundles moving into the opening roller.

A sliver may have more than 20,000 fibres in its cross-section. This means that a yarn of 100 fibres in a cross-section will require a total draft of 200. This amount of draft is substantially higher than that in ring spinning. Drafting in rotor spinning is accomplished first using an opening roller (mechanical draft) which opens the input sliver, followed by an air stream (air draft). The rapidly rotating opening roller combs out the leading ends of fibres. The separated trash is collected in a central chamber from where it can be removed. The fibre from the opening roller is sucked through a transport tube and deposited into the inner grooved surface of the rotor. The transport tube is tapered so as to create an accelerating air stream, which straightens the fibres. These two operations produce an amount of draft that is high enough to reduce the 20,000 fibres entering the opening roll down to few fibres (2–10 fibres) at the exit of the transport tube.

On landing in the rotor, centrifugal forces compress the fibres onto the collecting surface of the rotor. The fibres are accumulated in layers, forming a fibrous ring inside the rotor until the number in the cross-section reaches that for the desired yarn count. The ring of fibres is 'back-doubled' in the rotor groove and then consolidated by twist insertion. The number of doublings can be estimated by the ratio  $N/n$ , where  $N$  is the number of fibres in the yarn cross-section and  $n$  is the number of fibres in the air duct exit. The

total draft in rotor spinning is, therefore, a combination of true draft from the feed roll to the rotor (in the order of thousands) and a ‘back doubling’ to accumulate the fibre groups within the fibre ring inside the rotor. The total mechanical draft is the ratio between the delivery or the take-up speed and the feed roll speed. This should approximate to the ratio between the number of fibres in the sliver cross-section and the number of fibres in the yarn cross-section.

Consolidation in rotor spinning is achieved by mechanical twisting. The torque generating the twist in the yarn is applied by the rotation of the rotor. The amount of twist (turns per metre) is determined by the ratio between the rotor speed (rpm) and the take-up speed (metres/min). Every turn of the rotor produces a turn of twist. The winding operation in the rotor spinning is completely separate from the drafting and the twisting operations.

### 3.2.1 Fibre processing in rotor spinning

The extent of the opening action imposed by the combing roll will depend on the fibre length. As the fibre length increases, the force acting on the fibre beard increases significantly. This can result in fibre damage and wastage. Careful control of fibre length is therefore required for rotor spinning.

As the fibre flows around the combing roll, friction between the fibres and the metal chamber results in a lower fibre speed than the surface speed of the opening roll. This means that fibre attributes such as strength, friction, crimp, stickiness and surface finish are of particular importance to minimize friction and maintain speed of operation. Although the primary role of the opening roll is to open the fibres, it can also act as a cleaning unit by separating trash particles from the fibre. This additional function can easily overstress the opening roll, making it wear rapidly. In addition, the fine trash and dust content can accumulate in the rotor groove, leading to yarn defects and end breakages. It is important, therefore, that the input sliver should have a very high level of cleanliness. A maximum trash level of 0.1% is typically recommended by the machine maker.

As explained earlier, fibres leaving the opening roller become airborne and move through an air duct. This part of the drafting process is of special significance because of its impact on fibre orientation. Fibres can potentially be affected by turbulence as they flow through the air duct, causing poor orientation. Long fibres are more vulnerable to airstream disturbance than medium and short fibres. In order to minimize fibre disorientation, the airflow in the air duct should have a velocity exceeding that of the surface speed of the opening roller. Speed ratios ranging from 1.5 to 4.0 have been suggested. To obtain such a fast airflow, the inside of the rotor is run under reduced atmospheric pressure (i.e. a partial vacuum) which may be achieved by designing the rotor with radial holes to allow the rotor to generate its own

vacuum (self-pumping effect). Alternatively, an external pump can be used as is the case for most modern machines. Another approach to minimize fibre disorientation in the air duct is by designing it in a shape that is tapered towards the rotor to allow acceleration of the fibres as they approach the rotor inside surface. This action may also straighten the trailing fibre hooks.

As successive layers of fibres are laid into the inside surface of the rotor, a doubling action occurs. This action tends to even out minor irregularities in the yarn. This doubling action contributes significantly to the low irregularity and greater uniformity of rotor spun yarn. The elimination of the roving process also contributes greatly to the uniform quality of rotor yarn. If one observes a rotor spun yarn under a microscope, one will notice that along the yarn axis there are many fibres that are not completely tied into the yarn. These fibres have a free end that wraps itself around the yarn periphery. This is a characteristic that is peculiar to rotor spun yarns. These fibres are commonly called 'fibre belts' or 'wrapper fibres' [8]. Although wrapper fibres are technically a defect, their presence can enhance some fibre attributes. They form a tight belt round the yarn that can give it greater strength and a smoother surface. The proportion of wrapper fibres is often estimated using the ratio between the staple fibre length and the rotor circumference. Other fibre attributes that may contribute to wrapper fibres within a yarn include fibre stiffness and fineness. Stiffer and coarser fibres are more likely to become wrapper fibres.

One important feature that separates rotor spinning from ring spinning is tighter fibre control due to the higher spinning tension. As a result, less fibre migration occurs in rotor spinning, resulting in a more uniform fibre orientation in the yarn structure which produces smoother, more uniform yarns but with lower relative yarn strength. The impact of fibre friction in the rotor groove also results in some fibres that are only partially twisted, which also contributes to inferior yarn strength. These deficiencies can only be compensated for by high initial fibre strength and optimum fibre fineness.

Rotor spinning is more cost-effective than ring spinning in the manufacture of yarns with coarse to medium counts. In recent years, there have been many attempts to develop rotor spinning further into the area of fine counts, i.e. yarn counts finer than 40s cotton count [6].

### **3.3 Friction spinning**

The main operations in friction spinning are sliver feed, fibre opening, fibre transportation, fibre accumulation, twisting and winding. Friction spinning technology works on the principle of friction twisting [9–13] (Fig. 3.3). In this system, the pre-opened fibres are fed onto a moving, perforated collecting drum underneath which there is a suction device. The fibres are fed between this and a second rotating drum. Twisting occurs due to the frictional forces

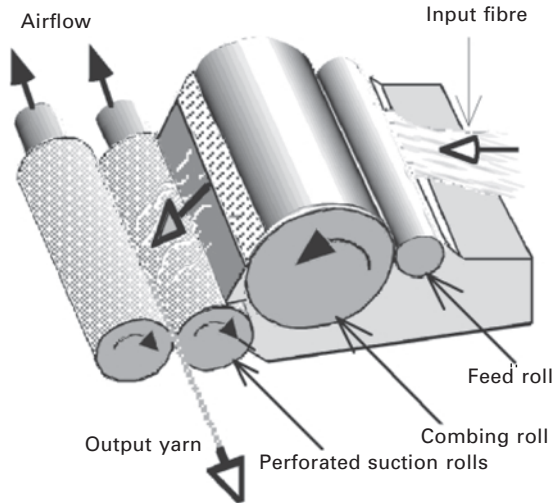

3.3 Friction spinning (courtesy of [3]).

between the drums and the fibre assembly. The process is also known as mechanical–aerodynamic spinning due to the fact that the spinning effect is produced by the movement of two spinning bodies (friction drums) assisted by air suction [10, 11]. Due to its versatility and high output speed of up to 300 m/min, the friction spinning system is considered suitable for producing yarns in the coarse count range, i.e. greater than  $20^s$  Ne.

Friction spinning was first developed when Fehrer produced the DREF friction spinning system in 1973. In this machine, the pre-opened fibres were made to fall onto a perforated cylindrical drum, the rotation of which imparted twist to the fibre assembly [14–16]. Due to problems in controlling the flow, slippage occurred between the fibre assembly and the perforated roller, which reduced the twist efficiency. Later the DREF-II friction spinning machine was developed to overcome this problem [11, 17–23]. This machine incorporates a specially designed inlet system which provides the required draft. These drafted slivers are opened into individual fibres by a rotating carding drum (opening roller) covered with saw-tooth wires. The individual fibres are stripped from the carding drum by centrifugal force supported by an air stream from a blower. The fibres are then transported by additional rollers to two perforated friction drums. The mechanical friction on the surface of the drums twists the fibres [14, 15, 18–20, 24]. Suction through the perforation of the drum assists the twisting process and helps in the removal of dust and dirt.

Feil [25] reported that Platt Saco Lowell's (PSL) Masterspinner is also a true open-end friction spinning system. It differs from the DREF-II in respect of fibre feed and the construction of the friction drums. The sliver

from the can enters the unit through a pedal system. The fibres are opened and cleaned by a pinned beater which also removes trash from the fibres. The opened fibres pass into a transfer duct located between the beater and the friction rollers and are drawn to the yarn formation zone at a 25–28° feeding angle by means of suction through the perforated roller. Smally [26, 27] has suggested that a secondary suction duct at the end of the transfer duct helps to give fibre orientation, and therefore to keep the fibres parallel to the yarn axis, resulting in improved fibre orientation and fibre extent in the final yarn. In the twisting assembly, one friction drum is perforated and includes a suction slot while the other is a solid roller which provides effective friction transfer. Smally [26–27] reported that, unlike in the DREF system, the spinning assembly is enclosed and so makes more efficient use of the air flow generated.

The DREF-III friction spinning machine was introduced into the market in 1981. This machine was developed to improve yarn quality, extend the yarn count up to 18<sup>s</sup> Ne and produce multi-component yarns. Balasubramanian [28] and Fehrer [29] reported that the DREF-III uses a core–sheath type friction arrangement as shown in Fig. 3.4. In this machine an attempt is made to improve the quality of yarn by aligning the majority of fibres in the direction of the yarn axis. The remaining fibres are wrapped round the core fibres to form a sheath. The sheath fibres are wrapped round the core fibres by the false twist generated by the rotating action of the drums. Two drafting units are used in this system, one for the core fibres and the other for the sheath fibres. This system produces a variety of core–sheath type structures and multi-component yarns using different core and sheath fibres in the count range of 1–18<sup>s</sup> Ne with delivery speeds as high as 300 m/min.

More recently Fehrer [30] reported the development of the DREF-5 friction-spinning machine in coordination with Schlafhorst and Suessen. Here the individualized fibres from a single sliver are fed through a fibre duct into the spinning system at an acute angle to the yarn axis so that they

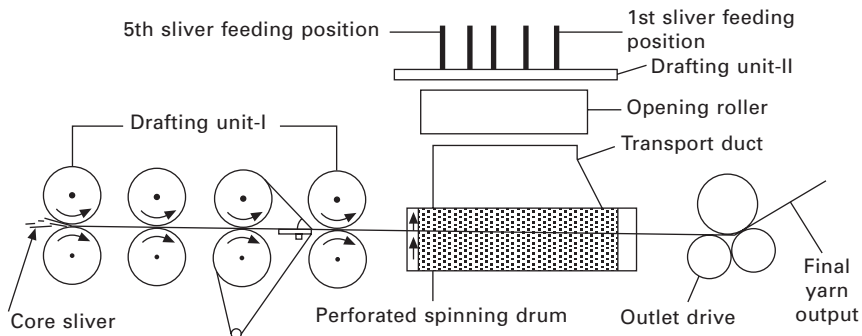

3.4 DREF-III friction spinning system.

are stretched as tightly as possible. It is possible to produce good quality yarn in the count range of 16–40<sup>s</sup> Ne at delivery speeds up to 200 m/min.

Ishtiaque [31] and Cheng [32] reported that the DREF-2000 employs a rotating carding drum which opens the slivers into single fibres. The fibres are stripped from the carding drum by centrifugal force and carried to two perforated spinning drums. As with previous designs, the fibres are subsequently twisted by mechanical friction on the surface of the drums which rotate in the same direction. The process is assisted by air suction through the drum perforations. The machine can produce ‘S’ and ‘Z’ twist yarn without having to be reconfigured.

According to Salhotra [75] the main advantage of the friction spinning system lies in its ability to generate a number of turns per unit length of yarn with one revolution of the twisting element. It is possible to spin yarn at a very high production rate of up to 300 m/min due to the low spinning tension required. This system can process a wide range of fibres. It is possible to produce a large package, therefore no rewinding is required. It is also possible to spin core-spun yarns and multi-component yarns on a DREF-III machine.

Friction spinning systems have a number of limitations which restrict their acceptance as a viable system for producing general-purpose yarns. The main drawback is lower yarn strength. Poor fibre orientation renders friction spun yarns relatively weak. The extent of disorientation and buckling is greater with longer and finer fibres. The twist variation from surface to core is quite high. This is another reason for the low strength of friction spun yarns. The count range is limited and it is not possible to produce fine yarn. Friction spun yarns have a higher tendency to snarl. Yarn unevenness and imperfections also increase as production speed increases.

### 3.3.1 Fibre processing in friction spinning

The opening roller assembly plays an important role in creating a stream of individualized fibres and is similar to that used in rotor spinning. Brockmanns [33] has recommended the use of garnet wire or needle pin-clothed opening rollers to cope with the high throughput. The feeding of slivers varies with the type of friction spinning machine. In case of the PSL Masterspinner and the DREF-5 friction spinning machine, a single sliver enters the unit through a fibre duct. Klein [13] reports that in the case of other DREF friction spinning machines a group of slivers arranged parallel to each other are fed through together. In comparing the two types of feeding system, Brockmanns and Johnson [34] found that the multiple-sliver feed system produces a higher rate and reliability of feed.

In the case of the DREF-II friction spinning machine, for example, slivers with a feed weight of 10–15 ktex can be fed. Lunenschloss and Brockmanns

[15] reported that the drafting unit for the DREF-II spinning system consists of a specially designed drafting unit. The drafting unit of two pairs of inlet rollers retains the slivers (normally five) and provides the required drafting. The drafted slivers are opened and separated into individual fibres by a rotating carding drum. The fibres are subsequently stripped off by air currents and deposited in the nip of the spinning drums.

As has been noted, the DREF-III spinning system uses two sliver feed units. A drafted single sliver of 2.5–3.5 ktex is fed into the drafting unit, forming the yarn core. A second drafting unit feeds five slivers which form the yarn sheath [35]. According to Fehrer [24], the first drafting unit consists of three drafting zones (with four pairs of rollers) which drafts the core sliver. The inlet speed varies from 0.85 to 8.5 m/min. There is also scope to feed a filament or a wire as the core component in a multi-component yarn. The core constitutes up to 80% of the yarn density. The second drafting unit consists of two pairs of inlet rollers which draft the sheath slivers. The inlet speed ranges between 0.12 and 1.2 m/min. The opening rollers rotate at 12,000 rpm and have a saw-tooth wire covering. The angle of the teeth can be varied, e.g. 10° for synthetic and 20° for cotton fibres.

A number of researchers such as Brockmanns [33], Brockmanns and Lunenschloss [36, 37], Brockmanns and Phoa [38], Fehrer [39], Lunenschloss and Brockmanns [21] and Stalder [40] have reported that the individualized fibres are transported by air currents through the feed duct and deposited in the nip of the spinning drums. These fibres are in free flight under the influence of the air current through the duct. It is essential to maintain a homogeneous fibre flow with proper alignment and orientation of fibres. Figure 3.5 shows the fibre opening and feeding device of the DREF-III friction spinner.

Johnson and Lord [41] reported that there is a practical problem of assembling fibres in the yarn with good orientation because of the varying amount of turbulence in the transport duct. The fibres move at very high speed through the duct but slow down on leaving the duct and arriving at the nip of the friction drum. This disrupts not only the fibre orientation but also the density of the fibre stream. As a result fibres are buckled, hooked and looped. This problem has also been discussed by Konda *et al.* [42], Lunenschloss and Brockmanns [14, 15], Klein [13] and Brockmanns and Phoa [38].

Several attempts have been made to find ways to deposit the fibres in as straight a condition as possible on the spinning drum to improve fibre orientation in the yarn. One device is the ‘Parallelisator’ or ‘Paradisc’ developed by Fehrer. This consists of a fan-like disc located in the flow-line of the opened fibres as they descend onto the spinning drum. The disc deflects the fibres down vertically in the direction of the yarn axis, maintaining the speed of the fibres as they move onto the drum. However, Brockmanns [33] has observed that this device is only effective with the use of longer fibres.

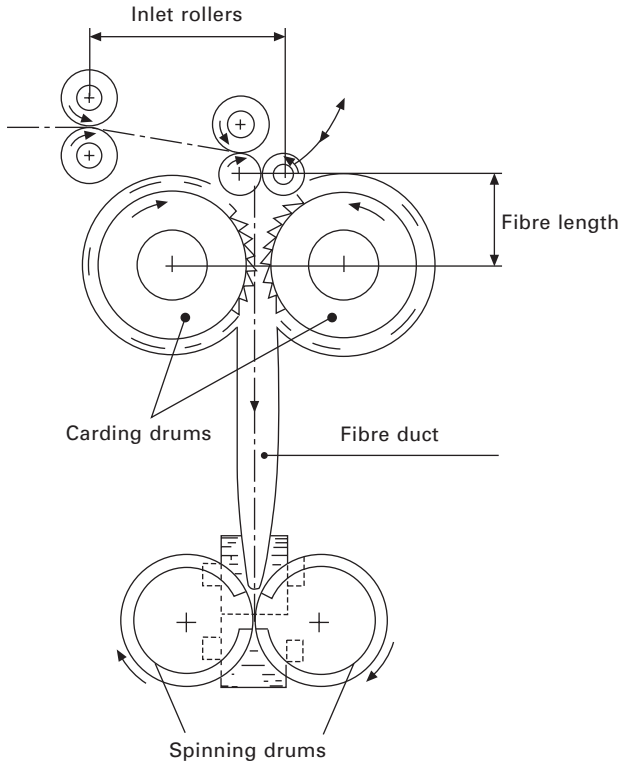

3.5 Fibre opening and feeding device of DREF-III friction spinner.

Lunenschloss and Brockmanns [21] have reported that the use of compressed air injection in the fibre feeding channel leads to improved fibre alignment in the feed duct.

There are two methods of fibre feed, namely vertical feed as used in DREF-II, DREF-III and DREF-2000 friction spinning machines, and inclined fibre feed as used in the PSL Masterspinner and DREF-5 spinning machine. In the DREF-II and DREF-III spinning system, multiple slivers are fed vertically. This method has been found to be suitable only for production of coarser yarns. According to Brockmanns and Phoa [38], feeding the fibre stream at an oblique angle onto the drum is the best solution for production of finer yarns. Lunenschloss and Brockmanns [21] have also suggested that inclined fibre feed offers advantages such as better fibre length utilization as well as spinning of finer yarns.

The process of twist insertion in friction spinning is considerably more complex than in ring and rotor spinning systems. Krause *et al.* [43], Lord *et al.* [44] and Lord and Rust [45, 46] have described fibre behaviour as fibres arrive in the accumulation zone. According to Brockmanns [33] and

Johnson and Lord [41], the yarn mass is made of discrete rotating fibres wrapped around a stationary core. However, Krause *et al.* [43] and Stalder and Soliman [47] argue that the fibres form an annular mass to which fibres are added externally and that some then migrate to the core, suggesting a more complex picture of fibre behaviour.

The fibre aggregate is assembled at the nip of the friction drums, held against the drum surfaces by suction and rolled by mechanical (frictional) forces caused by the rotation of the drums. The rotation creates a torque which twists the fibre assembly to create the yarn. The frictional forces are calculated according to Coulomb’s law of friction, taking into account the friction coefficients of the two spinning drums. According to Lord and Rust [45, 46], the two moving drum surfaces create a shear field which generates torque in the fibre assembly as given by the equation:

$$\text{Torque} = (\mu R_1 + \mu R_2) (d_y/2)$$

where  $\mu$  is the dynamic coefficient of friction between the fibre assembly and drum surface,  $R_1$  and  $R_2$  are the reaction components to the applied force ( $F$ ) on the fibre assembly, and  $d_y$  is the effective diameter of the fibre assembly at which the reaction forces act. The values of  $R_1$  and  $R_2$  can be calculated from the vector diagram shown in Fig. 3.6 or its equivalent mathematical form.

According to Lord [48], the geometry of the system greatly affects the ratios  $R_1/F$  and  $R_2/F$ . For that reason, the separation of the torque rollers and the yarn diameter are critical factors. The applied force  $F$  is caused by air flow from perforations in the drums. The spinning torque is a function of  $F$ . The movement of the yarn at different points means that the reaction forces ( $R_1$  and  $R_2$ ) vary in magnitude along the length of the yarn formation zone with the result that the torque distribution changes as shown in Fig. 3.7.

Rust and Lord [49] have shown that, during spinning, some fibres become loosely wrapped around the yarn tail while others are more tightly wrapped

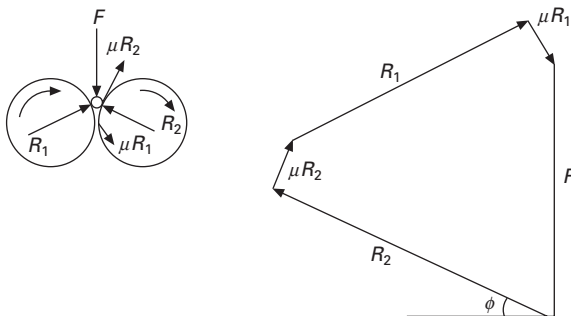

3.6 Vector diagram of forces acting on the yarn cross-section (courtesy of [48]).

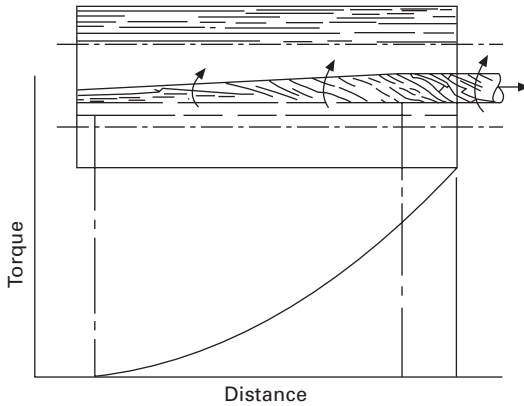

3.7 Theoretical torque distribution along the length of the fibre assembly zone in open end friction spinning.

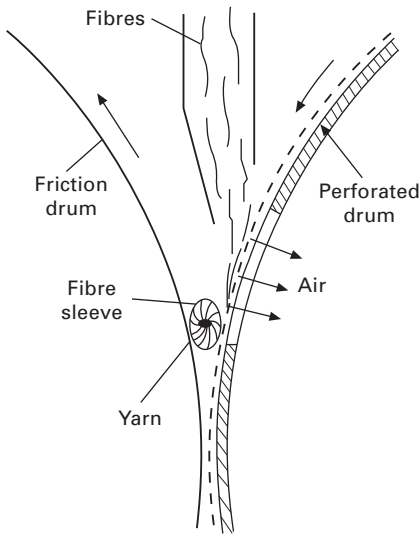

3.8 Fibre sleeve and mode of yarn formation.

around it. Stalder and Soliman [47] have shown that the yarn tail runs out in a cone shape and is surrounded by a more or less cylindrical sleeve of fibres as shown in Fig. 3.8. The twist is imparted to the yarn by the rotation of the fibre sleeve. They have proposed that the yarn twist ( $T$ ) is a function of fibre sleeve diameter ( $d_R$ ), the ratio of the perforated drum speed to yarn speed ( $Y$ ) and the diameter of the yarn tail ( $d$ ) and is expressed as:

$$T = f(d_R, Y, d_y)$$

Merati *et al.* [50] have also carried out a theoretical analysis of twisting, assuming a conical shape of the yarn tail in the yarn formation zone.

### 3.3.2 The structure of friction yarns compared to other types of yarn

Different researchers [51–55] have studied the fibre extent and orientation of open end friction spun yarn. Compared to other open end spinning systems, the internal structure of open end friction spun yarn is characterized by more inferior fibre orientation, buckled and folded fibre configurations and loose packing of fibres associated with lower tensions during yarn formation. The degree of fibre orientation and extension is so low that folded fibres of 40 mm length can be found in 10 mm long sections. These studies have reported approximately 50% fibre extent in yarns spun on a friction-spinning machine as against 80–85% in corresponding ring spun and 70–80% in rotor spun yarns.

Hearle *et al.* [56] have proposed that four parameters are required to characterize migration of a fibre in a yarn: mean fibre position, amplitude of migration, mean migration intensity and migration frequency. Rust and Lord [49] are of the view that this migration theory is not suitable for friction spun yarn. They have shown that the fibres in the friction spinning process move inward radially towards the apex of the ‘cone’ as they are assembled into the yarn. When a fibre is being wrapped about the cone with constant yarn axial velocity and constant rotational speed, the fibre helix angle ( $\alpha$ ) tends to decrease as a function of radial position [57].

There have been a number of studies comparing yarns produced by different spinning technologies [28, 58, 59]. However, these studies differ in terms of raw material, spinning conditions and machines used. In general, the count range for friction spinning is narrow and limited to 1–40<sup>s</sup> Ne. However, in practice for many machines only coarser yarns up to 14<sup>s</sup> Ne spin satisfactorily. Klein [13] and Parker [60] reported that, for coarse counts, the friction spinning system shows minimum yarn manufacturing cost as compared to other spinning systems. Krause [61] reported that it is possible to manufacture coarse yarns at a production speed of up to 300 m/min. Balasubramanian [28], Krause [61] and Oxenham *et al.* [62] have shown that the forces acting on the fibre assembly in friction spinning are relatively low. This results in lower tension which contributes to a high production rate and low levels of breakage but leads to inferior yarn strength as compared to that of ring and rotor spun yarns. This system is particularly suitable in producing multi-component yarns.

A number of studies [63–71] show that friction spun yarns are usually weaker than other yarns. Brockmanns and Lunenschloss [36, 37] showed that the imperfections in friction spun yarns are comparatively higher than

those in ring and air-jet yarns. Friction spun yarns are also more hairy than yarns from other spinning systems and are more susceptible to stripback and thus abrade easily. Manich *et al.* [70] reported that DREF-III yarns are more irregular in terms of twist, fibre density and evenness. Thierron [72] also reported that DREF-III yarns are more rigid and show a smaller resistance to abrasion than ring and rotor spun yarns. The values of flexural rigidity are about three to four times those of ring spun yarns [73]. Behera *et al.* [74] also compared the tactile and comfort properties of fabric woven from ring, rotor and friction spun yarns. They observed that, though fabrics woven from ring spun yarns are more tactile, fabrics from friction spun yarns are better for thermal comfort, but that these fabrics tend to sag during use.

### 3.4 Vortex spinning

Vortex spinning technology was introduced by Murata Machinery Ltd in Japan in 1997. This technology is best explained as a development of air-jet spinning, making use of air jets for yarn twisting. The main feature of Murata vortex spinning (MVS) is its ability to produce yarn at 400 m/min, which is almost 20 times greater than ring spinning frame production [76, 77, 78]. Other advantages include low maintenance costs, a fully automated piecing system and elimination of roving frame [79]. The yarn and the fabric properties of MVS yarn are claimed by the manufacturer to be comparable to those of ring spun yarn.

The basic principle of operation is shown in Figs 3.9 and 3.10. The sliver is fed to a *4-over-4* (or a *four-pair*) drafting unit. As the fibres come out of the front rollers, they are sucked into the spiral-shaped opening of the air jet nozzle. The nozzle provides a swirling air current which twists the fibres [79]. A guide needle within the nozzle controls the movement of the fibres towards a hollow spindle. After the fibres have passed through the nozzle, they twine over the hollow spindle. The leading ends of the fibre bundle are drawn into the hollow spindle by the fibres of the preceding portion of the fibre bundle being twisted into a spun yarn. The finished yarn is then wound onto a package.

#### 3.4.1 The structure of vortex yarn compared to other yarns

Vortex yarn has a two-part structure: a core surrounded by wrapper fibres. The number of wrapper fibres compared to the fibre core is higher than in air jet spinning. During yarn formation, the leading ends of the fibres are directed towards the yarn core and the trailing ends wrap around the core fibres. Such a structure provides the necessary fibre orientation and, at the same time, the required yarn strength.

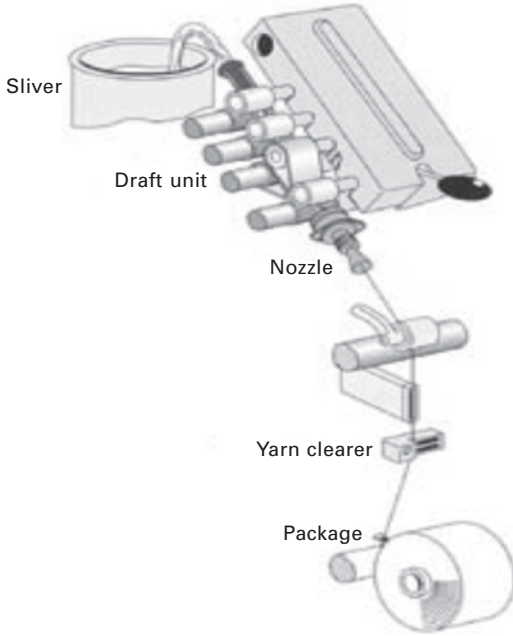

3.9 Feed material passage.

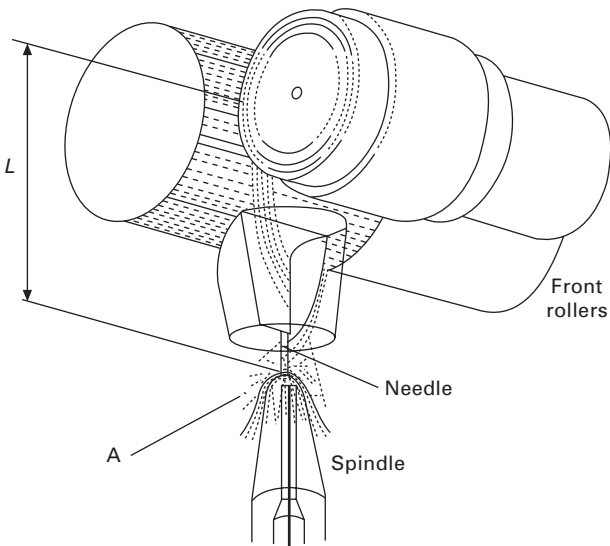

3.10 Expansion of fibre edges due to whirling force of the jet air stream.

One problem with the vortex system is significant fibre loss during yarn formation. This is related to the problem of variations in yarn quality which are not detectable by conventional evenness testers and sometimes only identified by weak points in the finished fabric. The paths followed by the fibres in the currents created by the air jets play a crucial role in yarn quality. Most structural defects are caused by the deflection of fibres in the air jet from their ideal path.

A study conducted by Ortlek and Ulku [80] shows the influence of different parameters on yarn properties. The study reveals that both delivery speed and yarn count are significant factors for yarn evenness and imperfections. An increase in delivery speed results in deterioration of yarn evenness. This is the result of decreasing efficiency of the air jet stream at higher delivery speeds because there is less time for the wrapper fibres to wrap around the parallel core properly. This particularly affects finer yarns and means that vortex spinning is best suited for coarser grades of yarn fibre. Nozzle pressure also has a significant effect on yarn properties. A higher pressure can improve strength because wrapper fibres wrap more tightly around the core. However, it can also lead to more lost fibres. This creates potential weak points and increases unevenness in the yarn. A low pressure leads to improved evenness, though strength is reduced. The distance between the front roller nip point and the tip of the spindle (indicated by  $L$  in Fig. 3.10) also affects yarn structure. The greater the distance, the higher the level of fibre wastage and yarn unevenness.

Soe *et al.* [81] compared vortex yarns with ring spun and rotor spun yarns. In vortex yarns, the centre of the yarn is not twisted. Twisting occurs at the outer sides of the yarn, as shown in Figs 3.11 and 3.12. Fibres at the centre of the yarn remain loose while those at the outer side are fully twisted [82]. In ring spun yarn, twist is given to the entire yarn from the centre to the surface of the yarn (Figs 3.13 and 3.14). The yarn thickness in vortex yarns

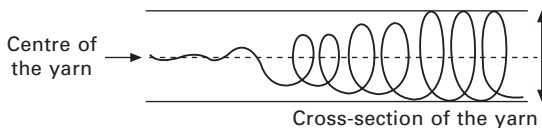

3.11 Vortex yarn cross-section.

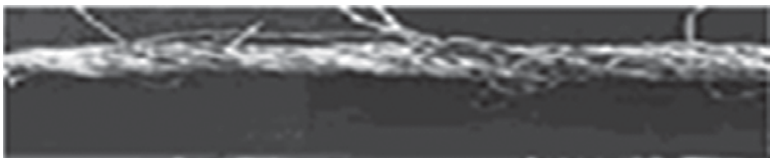

3.12 Micrograph of vortex yarn structure.

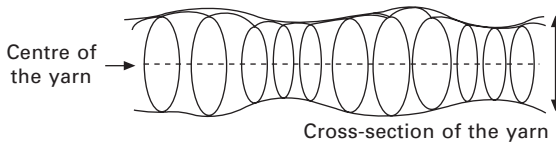

3.13 Cross-section of the ring yarn.

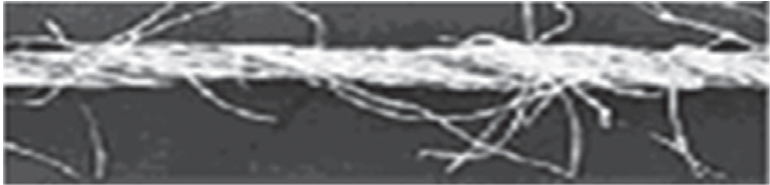

3.14 Micrograph of ring yarn structure.

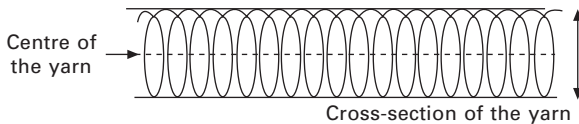

3.15 Cross-section of the rotor yarn.



3.16 Micrograph of rotor yarn structure.

is uneven. Twisting is concentrated at the thinner sections, while twisting is loose at the thicker section, leading to greater yarn hairiness. In the case of rotor spun yarn all the fibres are twisted from the centre to the outer side (Figs 3.15 and 3.16). Twisting is more uneven for fibres near the surface of the yarn. Table 3.1 compares the three types of yarns.

Figure 3.17 [81] compares twist in vortex, rotor and ring spun yarns. It shows that at the centre of vortex yarn there is zero twist in the fibres, i.e. they form a parallel alignment at the very centre. Twist increases towards the outer part of the yarn and is greatest in the outer wrapper fibres. Rotor spun yarns have a high twist at the centre of the yarn, which decreases towards the surface of the yarn. Ring spun yarns have a relatively consistent twisted structure from the centre to the surface of the yarn body.

The overall advantages of vortex yarn over ring spun and rotor spun yarns are:

Table 3.1 Comparison of yarn characteristics

Property	Ring yarn	Rotor yarn	Vortex yarn
Parallelization and fibre orientation	Max	Min	
Hairiness	Max		Min
Pilling	Max		Min
Strength	Max		Min
Unevenness	Max		Min
Surface smoothness	Max	Min	
Core fibres	Max		Min
Neps and thick places	Min		Max
Bulkiness		Min	Max

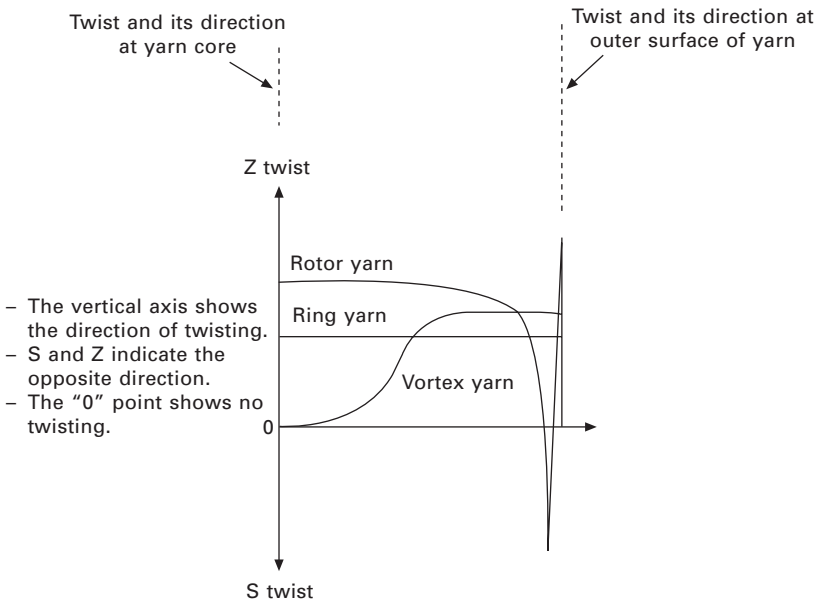

3.17 Difference in twist distribution between vortex, rotor and ring yarns.

- Better resistance to pilling and abrasion: this gives longer-lasting fabric performance through a greater number of washing cycles.
- Less hairiness: this reduces potential problems in fabric production and gives a smooth appearance to the fabric.
- Less shrinkage: unlike in ring spun yarn, the structure of vortex yarns means they are less prone to shrink.
- Moisture absorption and drying: the looser structure of fibres at the centre of vortex yarns means that they absorb moisture and dry quickly.

### 3.5 Conclusions

In this chapter, the fundamental principle of open end spinning is explained in detail. The advantages of open end spinning in comparison to ring spinning are explained. The structure of yarns produced with open end spinning is analysed and the end-uses for these yarns are provided. Rotor spinning, friction spinning and vortex spinning systems are three major methods of yarn manufacture developed on the principle of open end spinning. The working principles of these three systems based on open end spinning are explained in detail with their specific features. The structure and properties of the yarns produced with these three methods of open end spinning are compared with each other. The major limitation of the open end spinning technologies is that they are suitable for spinning coarser yarns and also that yarn strength is poor compared to that of ring spun yarns due to the relatively random alignment of fibres, although these methods of yarn production have very high production rates and yield more uniform yarns compared to ring spinning technology.

### 3.6 References

1. Haranhalli, A.S., 1990. *Practical Open End Spinning*, Mahajan Book Distributors, Ahmedabad, India.
2. Oxtoby E., 1987. *Spun Yarn Technology*, Butterworth-Heinemann, Oxford, pp. 138–212.
3. Lord, R.P., 2003. *Hand Book of Yarn Production*, The Textile Institute, Manchester, pp. 185–211.
4. Lawrence, C.A., 2003. *Fundamentals of Spun Yarn Technology*, CRC Press, Boca Raton, FL, pp. 281–342.
5. El Mogahzy, Y. and Gowayed, Y., 1995. Theory and practice of cotton fibre selection. Part I: Fibre selection techniques and algorithms. *Text. Res. J.*, **65**, 32–40.
6. <http://www.Cottoncinc.com>
7. Lord, P., 1981. *The Economics, Science and Technology of Yarn*, NCSU, Raleigh, NC.
8. Hunter, L., 1978. *The Production and Properties of Staple-Fibre Yarns Made by Recently Developed Techniques*. Textile Progress series (The Textile Institute), Volume 10, No. 1/2.
9. Derichs, J., 1983. Friction spinning and wrapping pose the main challenge. *Text. Month.*, **7**, 28–32.
10. Fuchs, H., 1979. Mechanical–aerodynamic friction spinning processes. *Melliand Textilber.*, (Eng. Ed.), **8**, 4, 275–277.
11. Fuchs, H., 1979. Mechanical–aerodynamic friction spinning processes. *Melliand Textilber.*, **60**, 4, 289–291.
12. Kimmel, L.B. and Sawhney, A.P.S., 1990. Comparison of Dref-3 cotton yarns produced by varying yarn core ratios and feed rates. *Text. Res. J.*, **60**, 12, 714–718.
13. Klein, W., 1993. New spinning systems, in *Manual of Textile Technology, Short Staple Spinning Series, Volume 5*, The Textile Institute, Manchester.

14. Lunenschloss, J. and Brockmanns, K.J., 1982. Review of open-end friction spinning. *Melliand Textilber.* (Eng. Ed.), **11**, 3, 174–181.
15. Lunenschloss, J. and Brockmanns, K.J., 1982. Review of open-end friction spinning. *Melliand Textilber.* (Eng. Ed.), **11**, 4, 258–259.
16. Gsteu, M., 1986. DREF: Progress with products, Part I. *Text. Horizons*, **6**, 10, 34–38.
17. Brockmanns, K.J. and Lunenschloss, J., 1984. Friction spinning analysed. *Int. Text. Bull., Yarn Forming*, **30**, 2, 5–23.
18. Gsteu, M., 1982. A spinning process makes the grade. *Int. Text. Bull., Spinning*, **28**, 1, 65–82.
19. Gsteu, M., 1982. New products with the DREF-2 spinning system. *Melliand Textilber.* (Eng. Ed.), **11**, 5, 319–322.
20. Gsteu, M., 1982. New products with the DREF-2 spinning system. *Melliand Textilber.* **63**, 5, 325–328.
21. Lunenschloss, J. and Brockmanns, K.J., 1985. Mechanism of OE friction spinning. *Int. Text. Bull., Yarn Forming*, **31**, 3, 29–59.
22. Lunenschloss, J. and Brockmanns, K.J., 1985. Whether OE spinning enhanced by friction twisting produces an alternative. *Text. Praxis Int.*, **40**, 2, 124–135, XV–XIX.
23. Fehrer, E., 1987. Friction spinning: the state of the art. *Text. Month.*, **9**, 115–116.
24. Textilmaschinenfabrik Dr Ernst Fehrer AG, 1983. The Dref-3 Friction Spinning System: Operating Instructions for DREF-3 Friction Spinning Machine. Linz, Austria.
25. Feil, R., 1984. Fine count friction spinning: how it works. *Text. World*, **134**, 1, 57.
26. Smally, E.G., 1985. Friction spinning. *Textile Asia*, June, 75–81.
27. Smally, E.G., 1985. Friction spinning – a new spinning technology. *Man Made Text. India*, July, 228–232.
28. Balasubramanian, N., 1992. Friction spinning – a critical review. *Indian J. Fibre Text. Res.*, **17**, 4, 246–251.
29. Fehrer, E., 1986. Friction spinning: the inventor's analysis. *Text. Month.*, **12**, 31–34.
30. Fehrer, E., 1987. Contribution on the state of development and the patent situation with regard to friction spinning machines. *Chemiefasern/Textilindustrie*, 37/89, April, E49–50.
31. Ishtiaque, S.M., 1999. Spinner's attraction at ITMA'99. *Asian Text. J.*, October, 27–32.
32. Cheng, K.P.S., 1999. ITMA 99 Survey 7: Unconventional spinning. *Textile Asia*, **9**, 15–26.
33. Brockmanns, K.J., 1984. Possibilities of OE-friction spinning. *Text. Month.*, **12**, 10–16.
34. Brockmanns, K.J. and Johnson, N., 1986. The influence of fibre feeding arrangements on the properties of friction spun yarn. *Int. Text. Bull., Yarn Forming*, **32**, 3, 27–34.
35. Gsteu, M., 1982. Industrial yarns manufactured with DREF technology. *Chemiefasern/Textilindustrie*, 30/8, July–August, E51.
36. Brockmanns, K.J. and Lunenschloss, J., 1984. Friction spinning analysed. *Int. Text. Bull., Yarn Forming*, **30**, 2, 5–23.
37. Brockmanns, K.J. and Lunenschloss, J., 1984. Friction spinning analysed. *Int. Text. Bull., Yarn Forming*, **30**, 3, 15–32.

38. Brockmanns, K.J. and Phoa, T.T., 1987. Theoretical and practical description of fibre moving and twist insertion during OE-friction spinning. *Int. Text. Bull., Yarn Forming*, **33**, 1, 55–67.
39. Fehrer, E., 1987. Friction spinning: the state of the art. *Text. Month.*, 9, 115–116.
40. Stalder, H., 1990. Spinning in the 90's. *Textile Asia*, February, 59–64.
41. Johnson, N.A.G. and Lord, P.R., 1988. Fluid flow phenomena in friction spinning. *J. Text. Inst.*, **79**, 4, 526–548.
42. Konda, F., Okamura, M., Merati, A.A. and Yokoi, T., 1996. Fibre speed and yarn tension in friction spinning. *Text. Res. J.*, **66**, 5, 343–348.
43. Krause, H.W., Soliman, H.A., and Stalder, H., 1989. Yarn formation in friction spinning. *Int. Text. Bull., Yarn Forming*, **35**, 4, 31–42.
44. Lord, P.R., Joo, C.W. and Ashizaki, T., 1987. The mechanics of friction spinning. *J. Text. Inst.*, **78**, 4, 234–254.
45. Lord, P.R. and Rust, J.P., 1991. Fibre assembly in friction spinning. *J. Text. Inst.*, **82**, 1, 109–113.
46. Lord, P.R. and Rust, J.P., 1991. Fibre assembly in friction spinning. *J. Text. Inst.*, **82**, 4, 465–478.
47. Stalder, H. and Soliman, H.A., 1989. A study of the yarn formation process during friction spinning. *Melliand Textilber.*, **70**, 2, 99–104, E44–E46.
48. Lord, P.R., 1987. Air-jet and friction spinning. *Text. Horizons*, **7**, 10, 20–24.
49. Rust, J.P. and Lord, P.R., 1991. Variation in yarn properties caused by a series of design changes in a friction spinning machine. *Text. Res. J.*, **61**, 11, 645–655.
50. Merati, A.A., Konda, F., Okamura, M. and Mauri, E., 1998. False twist in core-yarn friction spinning. *Text. Res. J.*, **68**, 6, 441–448.
51. Karnon, I., 1986. Friction spinning – the MasterSpinner. *Text. Month.*, 3, 34–37.
52. Krause, H.W., Soliman, H.A. and Stalder, H., 1991. Fibre assembly in friction spinning. *J. Text. Inst.*, **82**, 1, 113–114.
53. Ibrahim, A.R.B., 1995. Fibre orientation and utilisation in polyester open-end friction-spun yarns. *Indian J. Fibre Text. Res.*, **20**, 4, 211–213.
54. Looney, F.S., 1986. Synthetics for non-ring spinning. *Text. Month.*, 3, 38–45.
55. Dhamija, S., Sharma, V.K. and Salhotra, K.R., 2003. Influence of fibre length and yarn linear density on mean fibre extent in OE-DREF-II friction-spun yarns. *Indian J. Fibre Text. Res.*, **28**, 1, 108–113.
56. Hearle, J.W.S., Gupta, B.S. and Merchant, V.B., 1965. Migration of fibres in yarns, part I: Characterization and idealization of migration behaviour. *Text. Res. J.*, **35**, 4, 329–334.
57. Huh, Y., Kim, R.Y. and Oxenham, W., 2002. Analysing structural and physical properties of ring, rotor and friction spun yarn. *Text. Res. J.*, **72**, 2, 156–163.
58. Deussen, H., 1989. Conventional and novel short staple spinning systems. *Melliand Textilber.* (Eng. Ed.), **18**, 11, 815–820, E352–E354.
59. Gilmartin, R.J., 1987. World textiles into the 1990s. *Text. Month.*, 6, 33–36, 41.
60. Parker, A., 1991. Opportunities for friction spinning. *Text. Month.*, 11, 42–44.
61. Krause, H.W., 1985. Short staple-fibre spinning systems. *J. Text. Inst.*, **76**, 3, 185–195.
62. Oxenham, W., Zhu, R.Y. and Leaf, G.A.V., 1992. Observation on the tensile properties of friction-spun yarns. *J. Text. Inst.*, **83**, 4, 621–623.
63. Louis, G.L., Salaun, H.L. and Kimmel, L.B., 1985. Comparison of properties of cotton yarns produced by the DREF-3, ring and open-end friction spinning methods. *Text. Res. J.*, **55**, 6, 344–351.

64. Lunenschloss, J., Brockmanns, K.J. and Phoa, T.T., 1986. Cotton processing by new spinning technologies – possibilities and limits. *Int. Text. Bull., Yarn Forming*, **32**, 2, 7–22.
65. Stalder, H., 1988. New spinning methods, their application and possibilities for development. *Int. Text. Bull.*, **34**, 1, 29–39.
66. Ibrahim, A.R.B., 1995. Effect of back suction on the twist-tensile characteristics of open-end friction spun cotton yarns. *Indian J. Fibre Text. Res.*, **20**, 3, 60–62.
67. Neuhaus, L., 1986. Spinning processes as competitors. *Textile Asia*, October, 49–55.
68. Barella, A. and Manich, A.M., 1989. Friction spun yarns versus ring and rotor spun yarns: resistance to abrasion and repeated extensions. *Text. Res. J.*, **59**, 12, 767–769.
69. Barella, A., Alvarez Vega, P.A. and Castro, L., 1989. Yarn attrition by abrasion: a comparison of polyester-fibre/cotton blended-fibre yarns spun by different spinning processes. *J. Text. Inst.*, **80**, 4, 599–603.
70. Manich, A.M., de Castellar, M.D. and Barella, A., 1992. Twist and linear density coefficient of variation – length curve of polyester/cotton yarns spun by different processes. *Text. Res. J.*, **62**, 2, 115–120.
71. Padmanabhan, A.R., 1989. A comparative study of the properties of cotton yarn spun on DREF-3, ring- and rotor spinning system. *J. Text. Inst.*, **80**, 4, 555–562.
72. Thierron, W., 1985. The flexural rigidity of polyester-fibre-cotton yarns produced on the ring-, rotor-, and friction-spinning systems. *J. Text. Inst.*, **76**, 6, 454–458.
73. Chattopadhyay, R. and Banerjee, S., 1997. The frictional behaviour of ring-, rotor-, and friction-spun yarns. *J. Text. Inst.*, **88**, Part I, No. 3, 59–66.
74. Behera, B.K., Ishtiaque, S.M. and Chand, S., 1997. Comfort properties of fabrics woven from ring-, rotor-, and friction-spun yarns. *J. Text. Inst.*, **88**, 1, 255–264.
75. Salhotra, K.R., 1992. An overview of spinning technologies: possibilities, application and limitations. *Indian J. Fibre Text. Res.*, **17**, 4, 255–262.
76. Artzt, P., 2000. Yarn structure in vortex spinning. *Melliand International*, **6**, 107.
77. Leary, R.H., 1997. OTEMAS '97 Survey 1. Yarn formation. *Textile Asia*, **28**, 11–23.
78. Gray, W.M., 1999. How MVS makes yarns. *12th Annual Engineer Fibre Selection System Conference Papers*, 17–19 May.
79. Owen, P., 1999. Spinning – wider future options. *Text. Month*, August, 16–18.
80. Ortlek, H.G. and Ulku, S., 2005. Effect of some variables on properties of 100% cotton vortex spun yarn, *Text. Res. J.*, **75**, 6, 458–461.
81. Soe, A.K., Takahashi, M., Nakajima, M., Matsuo, T. and Matsumoto, T., 2004. Structure and properties of MVS yarns in comparison with ring yarns and open-end rotor spun yarns. *Text. Res. J.*, **74**, 9, 819–826.
82. <http://www.muratec-vortex.com/11.html>

**Abstract:** The blending of different quality fibres of the same type is a well-established technique for achieving quality and economic advantage. Blending of dissimilar fibres for improved appearance, comfort and performance has also become more common. Blow-room blending provides intimate blends. Post-carding or draw-frame blending generally blends two or three different fibres arranged at the creel.

**Key words:** blending, blow-room, draw frame, fibre, yarn, cross-section.

#### 4.1 Introduction: the purpose of blending

Natural fibres are inherently heterogeneous in their characteristics. Their characteristics are governed by various parameters. In the case of plant fibres these may include varieties of seed, place of cultivation, soils, humidity, temperature, irrigation and other cultivation techniques. In the case of animal fibres these parameters might include breed, location, type of pasture or other feed, type and quality of husbandry, etc. As an example, variations in length, diameter and other properties can be found in different cotton fibres from a single supplier or a group of suppliers from the same geographical location. Even synthetic fibres will vary according to raw material quality and variations in processing conditions.

Blending is a process of combining two or more fibres to improve product quality. The paramount objective of blending is to achieve a combined set of fibres with a set of properties which will satisfy a predetermined end use (Hamby 1965). Since individual natural and synthetic fibres will vary in characteristics and quality, blending fibres of the same type from different sources can be used to produce a more uniform and consistent product. It is also possible to blend different types of fibre to achieve particular yarn properties, though the blending process may be more complicated as a result (Anandjiwala *et al.*, 1999). Blending different fibre types can improve particular aesthetic or functional properties such as colour, feel, strength or insulation. As an example, in polyester–wool or acrylic–wool blends (Figs 4.1 to 4.4) both the blended polyester and acrylic fibres reduce wool fabric shrinkage, retain fabric shape and help the fabric to resist creasing or wrinkling while retaining the comfort and insulating properties of wool (Bergen, 1969). In polyester–cotton blends, the crease resistance of polyester helps to retain

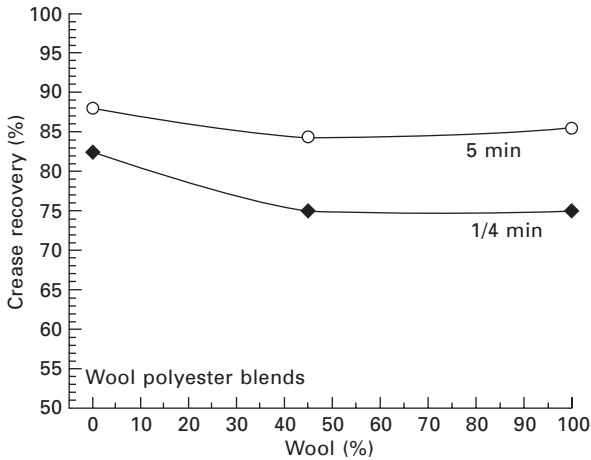

4.1 Blend of wool–polyester on fabric creasing (adapted from Bergen, 1969).

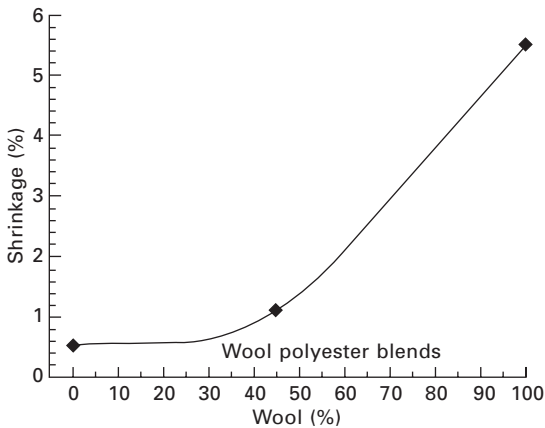

4.2 Blend of wool–polyester on fabric shrinkage (adapted from Bergen, 1969).

fabric shape without losing the comfort characteristics provided by the cotton (Bergen, 1969). Clothes using such a blend are more easily laundered, dry quickly and can be ironed using a lower temperature than pure cotton. The blending of nylon and wool makes the resulting fabric stronger and more durable whilst retaining the soft feel, insulating and absorbent qualities of wool. Table 4.1 illustrates some characteristics of wool, polyester and acrylic fibres. By using such information and blending two or three different fibre types, it is possible to engineer a range of properties into a fabric. Blending

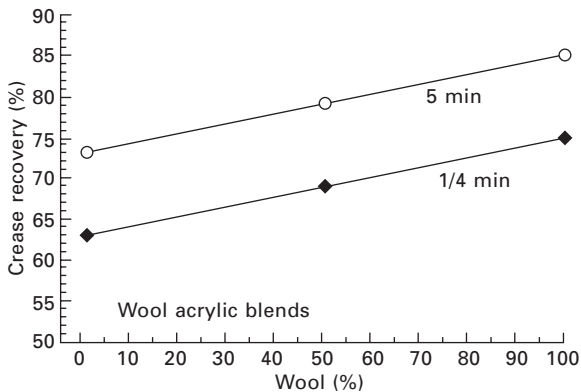

4.3 Blend of wool–acrylic on fabric creasing (adapted from Bergen, 1969).

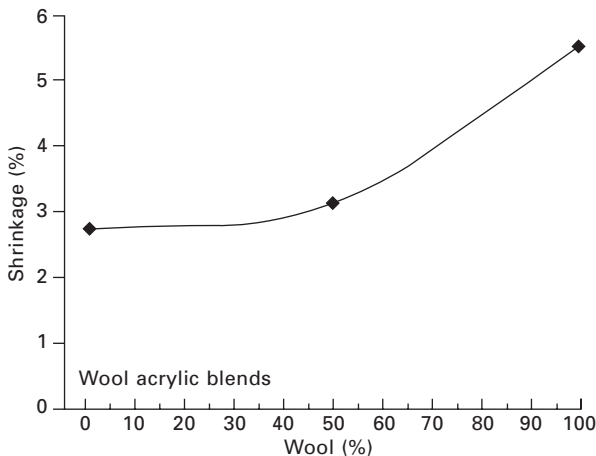

4.4 Blend of wool–acrylic on fabric shrinkage (adapted from Bergen, 1969).

Table 4.1 Some staple fibre properties

Fibre type	Tenacity (g tex <sup>-1</sup> )	Elongation (%)	Density (g cm <sup>-3</sup> )	Moisture absorption (%)
Wool	11.0	42.5	1.32	17.0
Polyester Dacron	47.0	37.0	1.38	0.4
Acrylic Orlon	27.0	25.0	1.14	1.5

Source: Extracted from Morton *et al.* (1975).

different fibres of varying price may also be important in balancing quality with cost.

## 4.2 Blending and yarn properties

Yarn structure is influenced by the radial disposition of fibres along the yarn length (Anandjiwala *et al.*, 1999; Hearle and Morton, 2008). Fibre arrangement in the yarn is highly influenced by blending. El-Behery (1968) noted that the physical properties of yarn depend not only on the proportion of each fibre type in the blend but also on the position of different constituent fibres in the blend. The type and quality of the blending process can therefore have a significant effect on yarn properties and functionality.

Blending is easiest to achieve if the component fibres are similar, for example in blending different quality cotton or wool fibres to keep the final product price competitive. Blending is more complex when different fibre types are involved. The main fibre characteristics which affect blending are fibre diameter and length. Other fibre parameters to be considered are surface characteristics, strength, crimp, flexural and bending rigidity. The regularity of fibre composition along the yarn length will have an effect on yarn strength and other characteristics, and eventually on the resultant fabrics.

A perfect blend involves laying fibres next to each other in an orderly three-dimensional structure. Figure 4.5 shows a cross-section of an idealised yarn

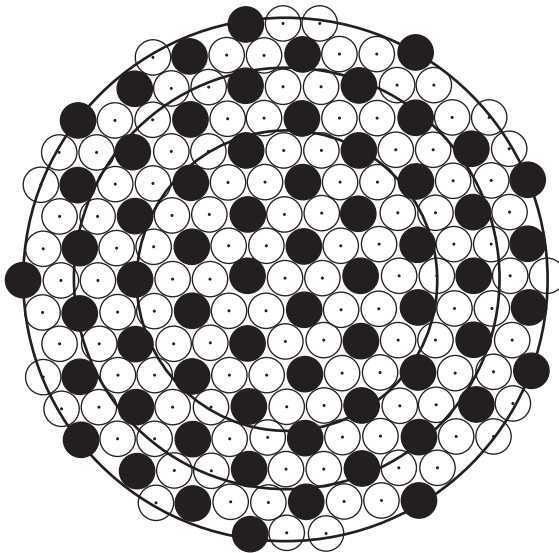

4.5 Idealised yarn cross-section (adapted from Scardino and Lyons, 1970).

by Scardino and Lyons (1970) with fibres aligned within concentric circular zones of equal area. Figure 4.6 shows an alternative model (Kremenakova and Militky, Liberec University, 2001). Many experts have argued that a perfect blend is impossible to achieve in practice. Hamby (1965) argued that a perfect blend would require knowledge of an almost infinite number of variables such as blending point, fibre type and physical characteristics (e.g. elongation, strength, rigidity and modulus). Lund (1952, 1954) argued that the best that could be achieved was a random distribution of the different fibres in the cross-section of the yarn. Lund (1952) argued that the distribution of fibres at the yarn cross-section is not as important as the overall distribution along the length of yarn. In practice a good blend can be defined as the same proportion of blended fibres in the yarn cross-section at any given point along the length of the yarn. Different methods have been suggested to quantify the proportions of different fibre types in the yarn cross-section by experts such as Cox (1954), Lund (1952, 1954), Hamilton (1958) and Zurek *et al.* (1982), including the index of blend irregularity (IBI) and modified versions of the chi-square test.

#### 4.2.1 Fibre fineness

In order to have a product which will blend more easily and will have appropriate characteristics such as softness on the skin, fibre fineness must

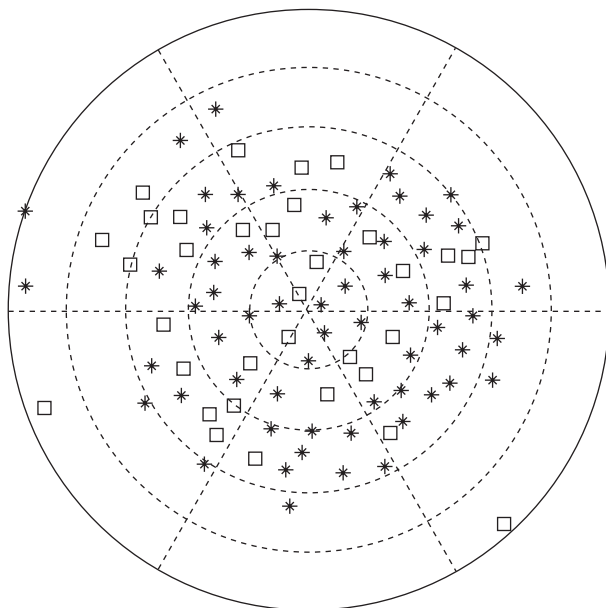

4.6 Fibre distribution at yarn cross-section (adapted from Kremenakova and Militky, 2001).

be considered. Fibre fineness can be defined in micronaire (**mg**/inch) which measures units of mass (micrograms or **mg**) per unit of length (inches) to assess linear density. Measuring micronaire is based on the theory of airflow through porous media. If one container is filled with fine and another identical container with coarser fibres, at a given airflow through both containers, the airflow in the container with the fine fibre would be less compared with the one with the coarse cotton fibre. This is due to the surface area which acts as drag on air flowing through the fibres. As fibre gets finer the surface area and resulting drag increase. This airflow method is used particularly for cotton due to the difficulty of measuring cotton fibre diameter in any other way.

Table 4.2 provides a simplified solution for measuring fibre fineness in bales. Hamby recommended a formula based on the number of fibres. He suggested the following formula for the average fibre micronaire (**mg**/inch) of blends for any combination of individual blend components (Jennings and Lewis, 1955; Croxton and Cowden, 1955):

$$M_{\bar{x}}(\text{micronaire}) = \frac{W_1 + W_2 + W_3 + \dots + W_n}{\frac{W_1}{M_1} + \frac{W_2}{M_2} + \frac{W_3}{M_3} + \dots + \frac{W_n}{M_n}} = \frac{\hat{A} W}{\hat{A} M} \tag{4.1}$$

where  $M$  is the micronaire of individual components,  $W$  is the weight of the blend components and  $M_{\bar{x}}$  is the average micronaire of the blend. In order to obtain the average fibre fineness in the blend instead of the fibre weight of components, the weight percentage can be used as in the following formula:

Table 4.2 Blend micronaire

Fibre mass (kg)	Mean fibre length (inch)	Mean fibre weight ( <b>mg</b> )
$W_1$ of 1st fibre	$L_1$ of 1st fibre	$w_1$ of 1st fibre
$W_2$ of 2nd fibre	$L_2$ of 2nd fibre	$w_2$ of 2nd fibre
...	...	...
$W_n$ of $n$ th fibre	$L_n$ of $n$ th fibre	$w_n$ of $n$ th fibre
<b>S</b> $W$ of fibres	<b>S</b> $L$ of fibre	<b>S</b> $f$ and <b>S</b> $w$ of fibres

Micronaire:  $\mu\text{g inch}^{-1}$

$$\sum_{i=1}^n W = \sum_{i=1}^n f_i w_i \ \backslash \ \text{blend micronaire} = \frac{\sum_{i=1}^n W}{\sum_{i=1}^n W_i L_i / w_i}$$

$W$  = fibre mass,  $w$  = weight of single fibre,  $L$  = fibre length

Source: Hamby (1965)

$$M_{\bar{x}}(\text{micronaire}) = \frac{P_1 + P_2 + P_3 + \dots + P_n}{\frac{P_1}{M_1} + \frac{P_2}{M_2} + \frac{P_3}{M_3} + \dots + \frac{P_n}{M_n}} = \frac{\hat{A} P}{\hat{A} M} \quad 4.2$$

where  $P$  is the weight percentage of the blend components.

### 4.3 Blending methods

As well as fibre characteristics, the quality of blending is affected by the technology used. Blending starts with the opening process. The proper arrangement or lay-down of bales at the start of processing is essential for effective blending. Blending can be carried out before or after carding. Blow-room blending before carding is called intimate blending. Blending after carding is referred to as creel or draw-frame blending, and can take place either at the draw frame or at the combing stage (Lord, 2003). The results of a study carried out by Chollakup *et al.* (2008) suggested that the fibres blended by the draw frame technique tended to migrate more towards the yarn core as compared to intimate (blow-room) blending. Shorter and coarser fibres, like cotton, tended to migrate towards the external yarn layer, whereas longer and finer fibres, like silk, tended to move towards the yarn core.

#### 4.3.1 Lay-down and bale opening

The arrangement of raw material at the start of processing, i.e. the laying down of different bales for initial mixing or blending, is important in achieving a consistent blend. The laying down of bales of different cotton qualities or a mixture of cotton and synthetic fibres, for example, could range from 10 to 200 bales as shown in Fig. 4.7. The number of bales in the lay-down depends



4.7 Bale opener (courtesy of Rieter).

on the capacity of the machine, the required blend ratio and production rate. As an example, to produce a 75/25 blend of different cotton fibres requires a minimum of four bales to lay down, i.e. three bales of one type and one bale of the other type. One of the major factors in successful blending is the separation of the mass of fibre aggregates into progressively smaller clumps. The effectiveness of the bale opener is important in blending in that it ensures that the fibre aggregates from each bale are relatively small and uniform, as can be seen in Fig. 4.7, making subsequent steps in blending more effective.

#### 4.3.2 Volume blending

The different fibres are fed continuously into hoppers. The principal components of the hopper feeder machine are shown in Fig. 4.8. The flow can be measured by the height of the blend in the hopper raw material compartment, assuming the density of the material and the rate of feed of the fibre components are constant during processing. Sensors can be used to measure the height of the blend in the hopper. A weigh pan hopper is largely the same as a volumetric hopper. The only difference is that, after the stripper roller separates the fibre tufts from the spiked lattice, it guides them to the weigh pan, as can be seen in Fig. 4.9. The accumulation of fibre tufts in the weigh pan continues until the preset weight is achieved before activating the flaps at the bottom of the pan to open, so as to drop the fibre tufts into the conveyor belt to transport fibres to the subsequent machinery. This provides better control of the blending process. More modern designs, however, favour continuous control over the more intermittent supply inherent

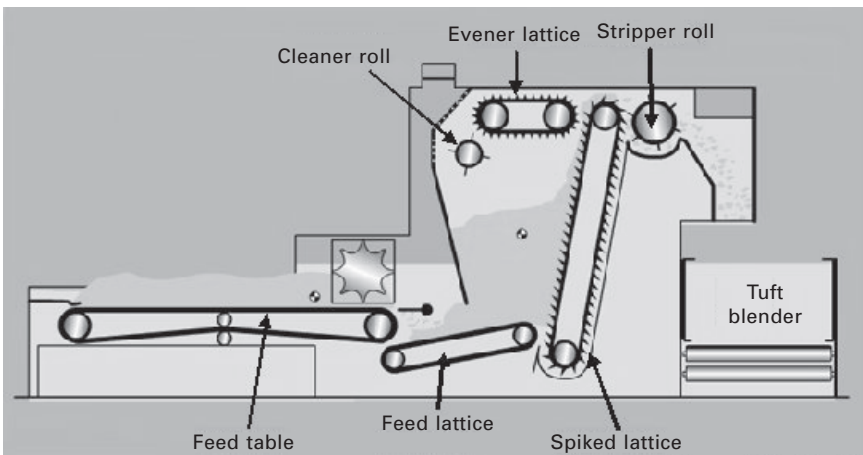

4.8 Hopper feeder (courtesy of Trützschler GmbH).

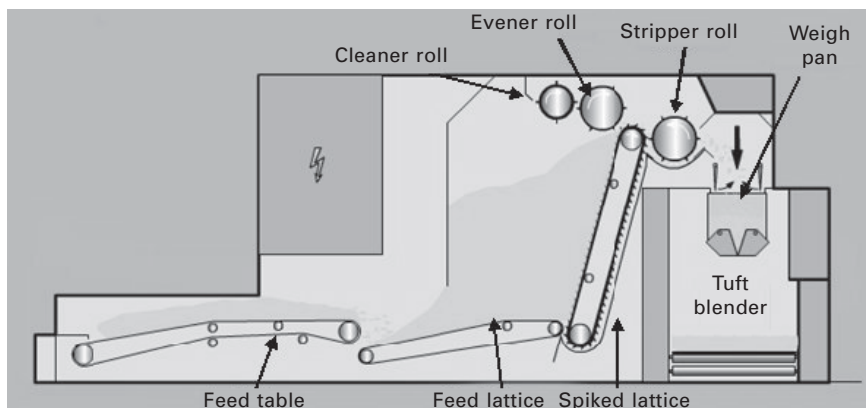

4.9 Weigh pan hopper (courtesy of Trützschler GmbH).

in weigh pan feeders. Some spinners recycle their waste through weigh pan feeders to give an even flow of waste rather than baling the waste and reintroducing it into the bale lay-down. This is effective in stabilising the waste percentage in the fibre stream (Lord, 2003).

Fibre tufts are fed from the hopper to the feed table and then, using a star roll, directed to the feed lattice, which takes the material to a spiked lattice. This helps to open the fibre tufts. Large tufts are moved upwards by the action of the spiked lattice to meet a second lattice which then reduces the tufts to a much smaller size depending on the distance between the two lattices. Excess tufts go back to the reservoir compartment. The stripper roll separates fibre tufts from the spiked lattice over a series of grid bars and then passes them through the docking trunk to the tuft blender conveyor belt for subsequent processing. The tumbling action helps to blend the fibres.

#### 4.3.3 Sandwich or layer blending

For the purpose of small batch blending a series of hoppers are arranged side by side as shown in Figs 4.10 and 4.11. Fibre tufts from each hopper drop on the conveyor. As the conveyor moves forward, fibre tufts from each hopper are dropped on those from the preceding hopper to form a series of layers like a sandwich. In this way different types of fibre, whether differing quality fibres of the same type, or fibres of different types, are combined before they proceed to the next stage (opening and cleaning). The opening roller separates a small portion from each layer for further processing. This helps to promote good blending. Stack blenders typically vary from four to 10 compartments. The main drawback to the stacking method is that it requires significant space for the series of hoppers, and the process is relatively slow. It is cost-effective for small batch production.

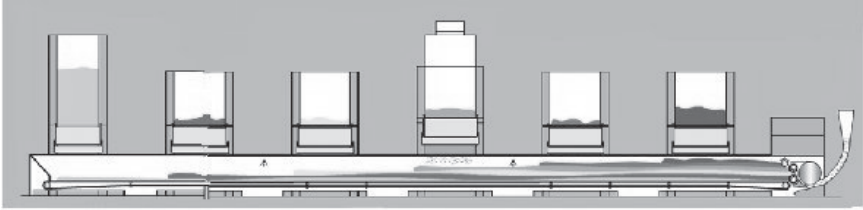

4.10 Batch blending (courtesy of Trützschler GmbH).

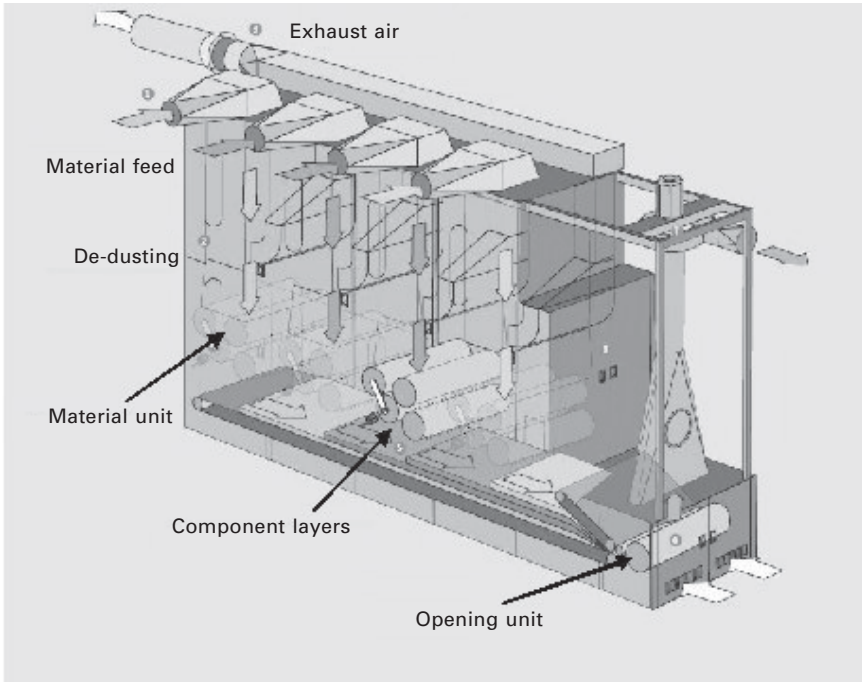

4.11 Blending unit (courtesy of Rieter).

#### 4.3.4 Bin or batch blending

This method is used mostly in the woollen industry. It is an intermittent system of blending operation. Where the wools being blended have similar characteristics, partially opened wools are layered horizontally into a blending bin (known as an accumulator). The rotary distributor at the top of the bin rotates to mix the fibre tufts. An inclined spiked lattice empties the bin from one end, providing further mixing. Where wools have different characteristics, multiple weigh belt lines deliver the different wools onto a conveyor for mixing in the accumulator (Simpson and Crawshaw, 2002). For further blending, fibres can be transported via an air current from a

hole at the bottom of one bin to a second rotary distributor at the top of a second bin. A significant degree of blending can be achieved, depending on the bin floor area and the weight of component layers fed from the bales (Lawrence, 2003). Bin or batch blending is more economical and faster than stack blending. A single opener and two bins are usually capable of handling 9 to 11 metric tons (Brearley, 1965). The principle of bin blending is shown in Fig. 4.12.

For further mixing and blending, a batch of fibre tufts is then fed to an opening and carding machine (such as a Fearnought) which breaks down the fibre tufts into much smaller ones for better mixing. The Fearnought machine includes a feed table to carry the tufts to the licker-in. The teeth of the licker-in comb the fibre tufts, reducing them in size prior to picking up by the cylinder. The fibre tufts are transported by the cylinder to a set of flats (which can be either fixed or moving) which open the tufts before they reach the doffer (Lord, 2003). In order to minimise the damage to the fibre, Fearnought cylinders and doffers use coarse metallic toothed wire. This process combines blending of fibres with opening and carding.

## 4.4 Carding

### 4.4.1 The carding machine

The carding machine is part of the fibre preparation process, but, with the exception of bin/batch blending in the woollen industry, it is not usually considered as part of blending. However, it can have important effects on blending, as discussed below. Carding is the last major opening process where individual fibres are separated, straightened and orientated in a common direction so that they can be converted to sliver (Lord, 2003). At the carding

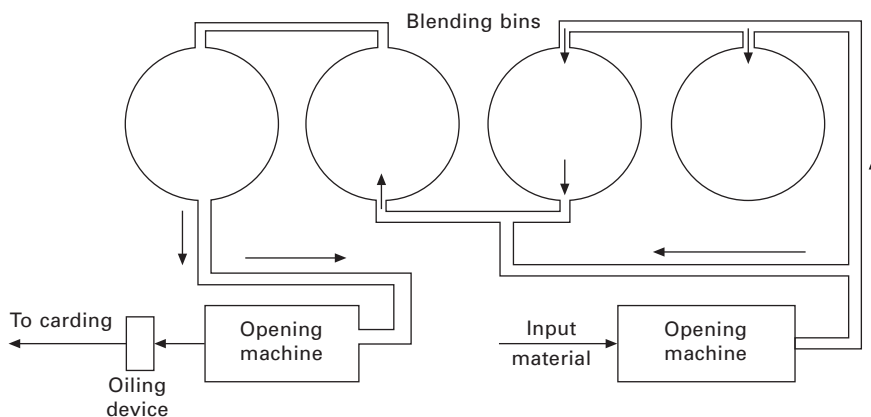

4.12 Bin blending unit.

machine, the licker-in (or fine beater) opens fibre tufts before the fibres are collected by the card cylinder (or swift in the case of worsted or woollen card). The fibres then become individualised (i.e. separated into single fibres) between the cylinder and the wire flats (or between the swift and worker and stripper rollers in the case of worsted or woollen card). They are then passed to the doffer and stripper to be turned into sliver.

The card cylinder holds on to the fibres during processing until it is fully covered by single/individualised fibres (i.e. loaded) before starting to pass them to the doffer, and the stripper for collection as sliver. This means that not all the fibres are collected immediately by the doffer with most recirculated. This action of holding onto the fibres (carding load) and the transfer on to the doffer, whilst new fibres are fed onto the cylinder from the licker-in, has an important effect on blending.

Simpson and Fiori (1974a,b) reported on the effect of blending of different cotton and cotton–synthetic fibre blends. They concluded that blends using a high percentage of low micronaire cotton reduced the rate of fibre transfer. This reduced productivity but had no adverse effect on blending or on strength, elongation or end down. In the case of a cotton–polyester blend, however, the higher surface frictional properties of the polyester meant that it did not transfer from the cylinder as readily as the cotton. As the proportion of polyester fibre increased, as shown in Fig. 4.13, the card cylinder load accumulated increasing polyester content in the blend beyond the desired ratio. The increased cylinder load also resulted in decreasing card sliver fibre orientation and increasing irregularities in the sliver.

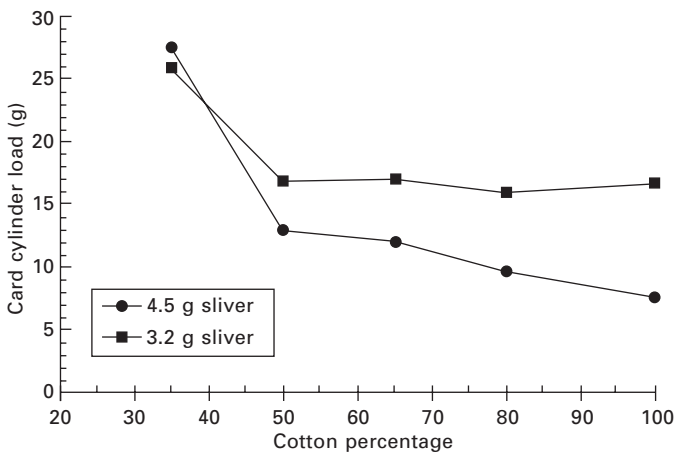

4.13 Effect of blending on carding load.

#### 4.4.2 Post-carding blending

An important part of the carding process is to ensure that individual fibres in the card sliver are straight and parallel with one another so that the sliver is even and regular. In order to improve card sliver evenness, at least eight card slivers are arranged side by side (called doubling) at the draw frame creel and are drawn into one sliver. In theory any irregularities in one sliver are counterbalanced by the others. When blending eight slivers by the doubling method at the draw frame, the resultant sliver contains one-eighth of each feed sliver. Eight slivers are blended into one. This can be an alternative way of blending fibres to blow-room blending. If drawing is repeated, with the slivers of the first draw fed into the second draw frame, the resultant output sliver will contain a 64th of each of the original slivers. If three draw frames are used, each original sliver will be one 512th of the final card sliver, as shown in Fig. 4.14. Optimum results are achieved after passing slivers through draw frames three times.

It is noticeable, however, that, even after passing through three draw frames, distinct fibre strips can be seen in the sliver using post-card blending. This is because, at the draw frame, fibres are not travelling as individual fibres but as a group. Increasing the number of draw frame stages beyond three does not reduce this problem. This demonstrates a clear difference between the two major blending systems, i.e. blow-room blending and draw frame blending. As is noticeable from Fig. 4.15, there are more groups of black fibres visible on the roving surface made from draw-frame blended sliver rather than on the one blended in the blow-room. As can be seen in Fig. 4.16, two yarns spun by ring spinning using these rovings also show different distributions of black and white fibres. The higher proportion of black fibres shows the difference between and the relative superiority of blow-room over

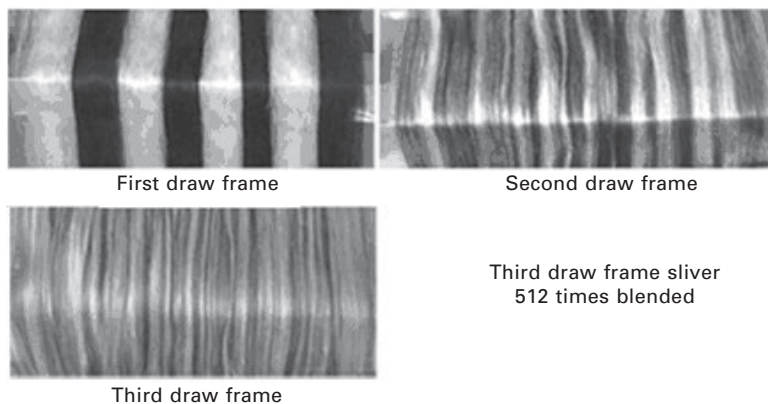

4.14 Draw-frame blending.

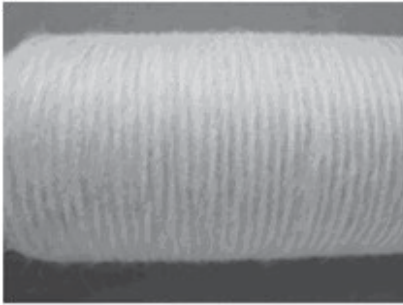

Rieter draw frame roving



Rieter uniblend roving

#### 4.15 Effect of blending methods on roving.

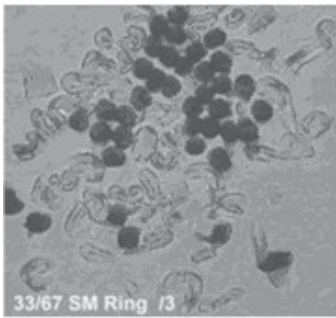
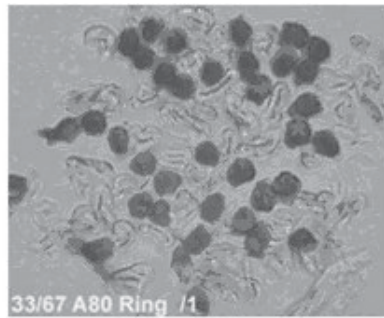
33/67 SM Ring /3  
Rieter draw frame ring yarn33/67 A80 Ring /1  
Rieter uniblend ring yarn

#### 4.16 Effect of blending methods on ring yarn.

draw-frame blending. The ratio of blended black and white fibre at yarn cross-sections is shown in Fig. 4.17, and the difference using blow-room and draw-frame blending can be seen in Figs 4.18 and 4.19 respectively. Lund (1954) argued that, although the distribution of black fibre in the two yarns cross-section obtained from blow-room and draw-frame blending was not very different, the difference in characteristics of the two yarns and fabrics was significant. As has been noted earlier, research by Chollakup *et al.* (2008) has also suggested that the fibres blended by the draw-frame technique tend to migrate more towards the yarn core as compared to intimate (blow-room) blending, producing greater unevenness in the final yarn.

## 4.5 Measuring the effectiveness of blending

Identifying the constituent fibres and their proportions in a blended yarn or fabric is a skilled activity. The fibre mixture must be visually identified by a microscope and then by chemical tests (Zhong and Xiao, 2008). The amount of each fibre is then determined either by physical separation of individual

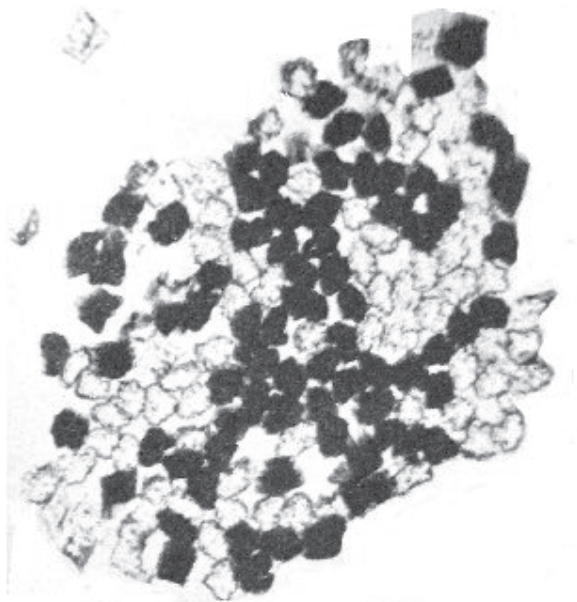

4.17 Yarn cross-section (adapted from Lund, 1952).

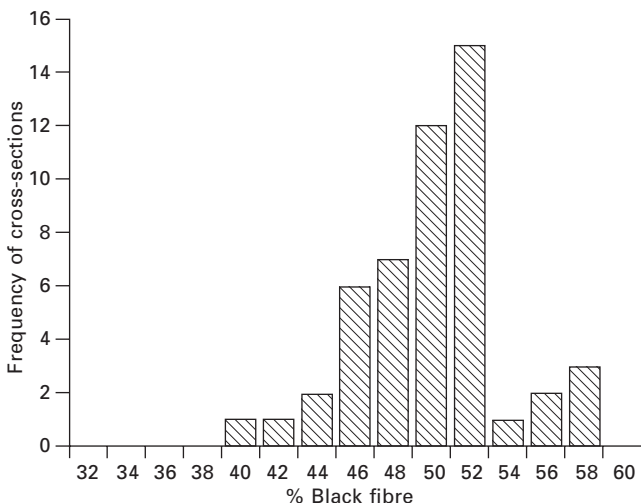

4.18 Blow-room blended fibres (adapted from Lund, 1952).

fibres or by chemical extraction of one fibre at a time using gravimetric analysis to give a composition result. Traditional tests include optical, density, chemical, staining and burning tests. Newer methods include scanning electron microscopy (SEM), environmental scanning electron microscopy (ESEM) and computer image processing technology.

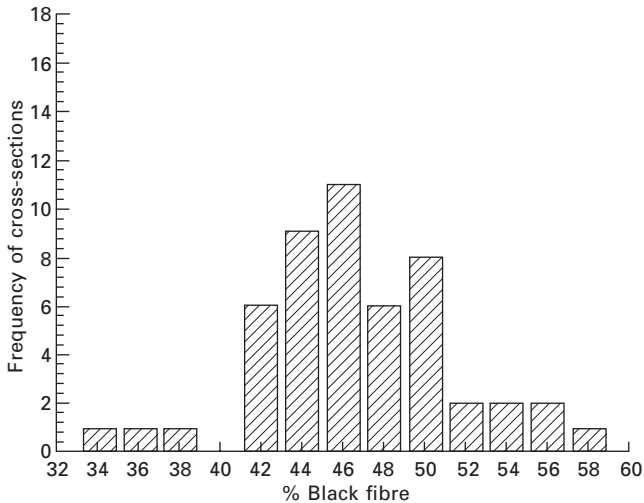

4.19 Draw-frame blended fibres (adapted from Lund, 1952).

The quality and uniformity of blending can be measured more indirectly by measuring a range of fibre attributes in different samples. If a blend were perfectly homogeneous, there would be no variation in fibre attributes over any number of samples. The degree of variation in particular attributes across samples, measured by changes in the coefficient of variation (CV) for a particular attribute, provides some measure of the quality and consistency of blending (Lord, 2003). Individual attributes (used particularly in the cotton industry) include:

- Micronaire (MIC): a measure of fibre fineness (discussed above)
- Upper half mean length (UHM): the mean quantity of longer fibres in a sample, longer fibres contributing most to yarn strength
- Fibre tenacity (STR): a measure of fibre strength (usually measured in mN/tex)
- Fibre elongation at break (ELO): another measure of strength
- Fibre reflectance ( $R_d$ ): measured by a Nickerson–Hunter colorimeter according to ASTM standard D2253.

Lord (2003) reports results from samples at different stages in the production of cotton (Table 4.3). The results show a steady improvement in the CVs for particular attributes during different production stages, illustrating how blending is affected during processing, though they show slight increases for CVs after drawing. Similar results were found in a study by El-Mogahzy and Mahrous (1999).

Table 4.3 Effect of processing stages on fibre characteristics

Stages	MIC	UHM	STR	ELO	Rd	Trash/g	Dust
Bale	14.4	5.0	8.3	12.1	6.3	87	73
Chute feed	2.4	1.7	5.5	6.3	1.1	16	51
Card sliver	3.1	1.3	3.8	5.0	1.2	28	28
First drawing	2.1	1.4	3.3	5.5	1.6	24	27
Second drawing	2.9	2.1	3.5	6.2	1.5	24	8

Source: Lord (2003).

## 4.6 References and sources of further information

- Anandjiwala, R. D. *et al.* (1999) *Textile Research Journal*, Vol. 69, p. 129
- Bergen, W. V. (1969) *Wool Handbook*, Volume 1, Third Edition, Wiley Interscience, New York, London
- Brearley, A. (1965) *The woollen Industry*, Pitman, London
- Chollakup, R., Osselin, J.-F., Sinoimeri, A. and Drean, J.-Y. (2008) *Textile Research Journal*, Vol. 78, p. 361
- Cox, D. R. (1954) *Journal of the Textile Institute*, Vol. 45, p. T113
- Croxtton, F. E. and Cowden, D. J. (1955) *Applied General Statistics*, Prentice Hall, New York, p. 226
- El-Behery, H. M. (1968) *Textile Research Journal*, Vol. 38, No. 4
- El-Mogahzy, Y. and Mahrous, M. (1999) National Textile Centre Annual Report, November F99–A13
- Hamby, D. S. (1965) *The American Cotton Handbook*, Volume 1, Third Edition, Wiley, New York, London, Sydney
- Hamilton, J. B. (1958) *Journal of the Textile Institute*, Vol. 49, p. T423
- Hearle, J. W. S. and Morton, W. E. (2008) *Physical Properties of Textile Fibres*, Fourth Edition, Woodhead Publishing, Cambridge
- Jennings, E. J. and Lewis, H. G. (1955) *Textile Research Journal*, Vol. 23, No. 3, p. 267
- Kremenakova, D. and Militky, J. (2001) Identification of bundles in blended yarns, Department of Structures and Department of Textile Materials, Technical University of Liberec, Halkova 6, 46117 Liberec, Czech Republic
- Lawrence, C. A. (2003) *Fundamentals of Spun Yarn Technology*, Woodhead Publishing, Cambridge
- Lord, P. R. (2003) *Hand Book of Yarn Production: Technology, Science and Economics*, Woodhead Publishing, Cambridge
- Lund, G. V. (1952) *Journal of the Textile Institute*, Vol. 43, p. 375
- Lund, G. V. (1954) *Textile Research Journal*, Vol. 24, p. 750
- Morton, W.E. and Hearle, J.W.S. (1975), *Physical Properties of Textile Fibres*, Second Edition, Published by Win Heinemann and the Textile Institute.
- Nuding, H. (1952) *Journal of the Textile Institute*, Vol. 43, p. 352
- Scardino, F. L. and Lyons, W. J. (1970) *Textile Research Journal*, Vol. 40, No. 6, p. 573
- Simpson, J. and Fiori, L. A. (1974a) *Textile Research Journal*, Vol. 44, No. 5, p. 327
- Simpson, J. and Fiori, L. A. (1974b) *Textile Research Journal*, Vol. 44, No. 10, p. 813
- Simpson, W. S. and Crawshaw, G. H. (2002) *Wool: Science and Technology*, Woodhead Publishing, Cambridge
- Zhong, Z. and Xiao, C. (2008) 'Fabric composition testing', in J. Hu (ed.), *Fabric Testing*, Woodhead Publishing, Cambridge
- Zurek, W. Krucinska, I. and Adrian, H. (1982) *Textile Research Journal*, Vol. 6, p. 473

## Yarn structure and properties from different spinning techniques

---

G. K. TYAGI, The Technological Institute of Textile and Sciences, India

**Abstract:** This chapter presents a systematic and comprehensive study of unconventional staple yarns, their structural features, properties, factors influencing their properties, structure–property relationships, applications, and the possibilities for future developments. The quality aspects of ring, rotor, air-jet and friction spun plied yarns are also discussed.

**Key words:** air-jet spinning, Dref-3 friction spun yarn, plied yarns, rotor spun yarn, wrapper fibres, wrap spinning.

### 5.1 Introduction

The textile industry has witnessed many exciting technological innovations in spinning machines since the late 1960s. Machinery manufacturers looked for alternatives to ring spinning which seemed to have reached a plateau in regard to maximum production speeds. Ring spinning offered little scope for further development and impeded all efforts directed towards automation of the whole spinning process. The power consumption was also seen to be disproportionately high at faster spindle speeds. These disadvantages laid the foundation for the development of alternative methods of spinning, particularly for higher production speeds. As a result, various new spinning technologies based on radically different principles of fibre consolidation appeared. Among the new spinning technologies introduced in the late sixties and early seventies, only rotor spinning established itself on a significant scale in comparison to ring spinning, going on to claim a major share of coarse yarn production. This was achieved mainly on the basis of its lower cost of production and amenability to automation. Despite these positive aspects, there was a growing realization that rotor spun yarns would have limited end uses, particularly as these yarns impart a harsh feel to the fabric. These constraints therefore restricted rotor spinning to coarse and medium counts.

Research and development of other high production technologies for finer counts resulted in three prominent systems: air-jet, friction and wrap spinning. All three have met with varying degrees of acceptability. The air-jet

system appeared to offer real promise of commercial success because of its technological superiority to conventional systems over the finer yarn count range of 7.5 tex to 12 tex. Friction spinning, on the other hand, produced yarns of more acceptable quality due to their pliability imparted by real twist. This system offers greater scope in production of high-tech yarns for technical fabrics, filters and other applications. Wrap spinning, which appeared in commercial form earlier than air-jet and friction spinning, has become important for certain specific applications where the use of a filament binder is not objectionable. Further studies into spinning technologies brought out the drawbacks in these new yarns and led to the current practice of engineering yarns for producing specific textile substrates. There is a consensus that each of these technologies produces different structural features depending mainly on the properties of the constituent fibres and the inherent characteristics of the processing system. These differences in internal structure are reflected in different performance characteristics.

The following sections are intended to deepen understanding of structure, properties and influencing parameters, structure–property relationships, quality control and end uses of the yarns spun by ring and new spinning technologies.

## 5.2 Ring spun yarns

### 5.2.1 Structural features of ring spun yarns

#### *Surface structure*

Most yarns made from staple fibres are ring spun yarns. The twist that provides the final entanglement is built up from the outside to the inside. Although a high quality ring yarn first appears to be as uniform as a filament, closer microscopic examination would reveal a uniform helical arrangement of fibres at the surface, as shown in Fig. 5.1. Also noticeable would be an outer fringe of fibres known as the fuzz-zone caused by protruding fibre ends. The twist is the same across the yarn cross-section (Chattopadhyay, 1993). Consequently, if twist is removed by untwisting on a twist tester, one may observe a parallel bundle of fibres at some point of time, indicating complete removal of twist. Fibres can be highly packed in the yarn and thereby produce a compact structure. The packing coefficient generally ranges between 0.5 and 0.6. The closed packing is caused by the high level of tension acting on the fibres at the yarn formation point.

#### *Migration*

The term fibre migration is used to describe the relative movement of a fibre with respect to neighbouring fibres during the process of twist insertion into

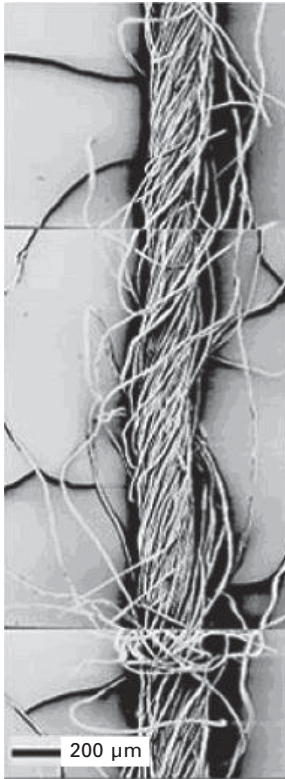

5.1 Ring spun yarn surface structure.

the fibre assembly and the ultimate position of the fibre in the final yarn structure. The phenomenon of fibre migration in the processing of fibres, filaments and blends has been studied by many since the earlier work of Morton and Yen (1952). A very thorough treatment of fibre migration in yarn structure is found in structural mechanics of fibres, yarns and fabrics by Hearle *et al.* (1969).

Fibre migration, which is expressed by various parameters and indices, depends on fibre properties, the characteristics of the fibre assembly, and the processing conditions. The fibre properties include length, degree of elasticity, stiffness and fineness. Short, coarse and stiffer fibres move out of the core towards the sheath, while long, fine and flexible fibres move towards the core. Strongly crimped fibres are also found predominantly in the sheath. In blends of fibres with substantially different processing characteristics, preferential radial migration occurs; one component of the blend is found primarily in the core and the other component mostly near the surface.

Fibre migration is caused largely by the existence of varying fibre tensions at the point where the strand is twisted. Fibres at high tension try to relieve

their tensions by migrating to the core. Relatively slack ones are displaced outwards. In ring spinning, the fibre tensions are generated in the delta zone where the fibres leave the nip of the front drafting rollers and pass into the twisted yarn.

Table 5.1 shows the typical values of migration parameters for ring spun viscose rayon yarns. The mean fibre position has a value ranging between 0.33 and 0.38, implying greater packing density near the centre of the yarn with increasing twist. Migration takes place from the sheath to the core and vice versa. Root-mean-square deviation values are almost half of the value expected for ideal migration. The ideal migration pattern is essentially one in which the fibre migrates regularly and uniformly from the outside to the centre of the yarn and then back to the outside, in such a way that the density of packing of fibres in the yarn is constant throughout the yarn. The mean migration intensity values, which indicate the mean rate of change of radial position, range between 0.12 and 0.49 depending upon the level of twist (Hearle *et al.*, 1969). Figure 5.2 illustrates the cyclic path migration of the fibres moving from one cylindrical layer to another.

Table 5.1 Migration parameters in a spun rayon yarn

	Twist factor			Value for complete ideal migration
	2.1	3.0	6.0	
Mean fibre position	0.33	0.36	0.38	0.5
CV%	39	32	22	
RMS deviation	0.17	0.16	0.21	0.29
CV%	28	20	12	
Mean migration intensity (cm <sup>-1</sup> )	0.12	0.17	0.49	–
CV%	32	24	22	
Equivalent migration frequency (cm <sup>-1</sup> )	0.10	0.16	0.34	–
CV%	25	23	19	

Source: Hearle *et al.* (1969).

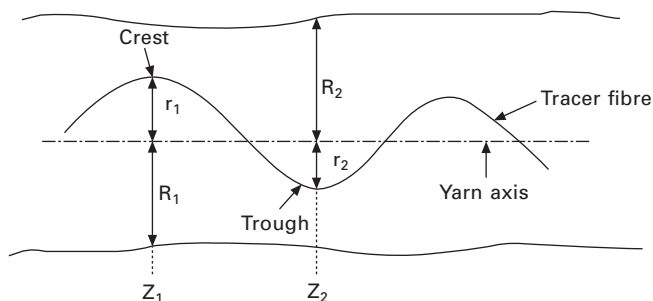

5.2 Tracer fibre path in ring spun yarn structure.

## 5.2.2 Properties of ring spun yarns

### *Tensile properties*

Breaking strength and elongation are two prime quality attributes of any spun yarn. The strength and elongation of a yarn are important to the processability of the yarn in the downstream processing and operational life of the substrate made with the yarn. The strength of a staple yarn is determined by various fibre properties, the yarn structural geometry and the spinning parameters. It is known that yarn strength increases first to a maximum value with increase in twist and then falls with further increases in twist. One traditional explanation of this change in strength with twist is based on the combination of slippage and breakage of fibres. At low twist factors, the initial increase in yarn strength is determined by the resistance of fibres to slippage. At high twist factors, the contribution from resistance to slippage reaches a steady maximum. However, as the twist factor becomes high, the effect of fibre obliquity comes into play, and this has a tendency to cause a decrease in yarn strength. The twist–strength relationship is therefore the result of the combined influence of these two factors. The twist at which yarn strength is highest is called the optimum twist. This optimum value of twist is largely determined by the fibre length, fibre fineness, fibre strength and the fibre coefficient of friction, in addition to the count of the yarn being spun.

### *Mass irregularity and imperfections*

Another important quality parameter of the yarn is its mass unevenness along its length. This unevenness is the result of the variation in the number of fibre ends per unit length. Martindale (1945) showed that a random distribution of fibre ends would give the lowest unevenness, termed the ideal unevenness. The random distribution of fibre ends is based on the premise that each fibre is separate from the others and can move independently. The unevenness or irregularity increases as the fibre dynamics move away from this situation, which is the case for current spinning systems. For example, in ring spinning, roller drafting does not give a random distribution of fibres in the cross-section but a quasi-periodic variation due to the phenomenon of drafting wave formation in the drafted ribbon of fibres. Thus, when the ribbon is twisted to form the yarn, the drafting wave adds to the ideal unevenness, thereby increasing the irregularity of the spun yarn.

The important measures that can reduce yarn irregularity and associated imperfections are (1) individualization of fibres, (2) minimization of inter-fibre contact by greater fibre parallelization, and (3) control on the movement of short fibres. The first requirement puts greater demands on the carding operation, whereas the second requirement necessitates maximum parallelization during drawing, roving production and ring spinning. The control of the movement

of short fibres depends on the sophistication of the drafting system as well as the fibre characteristics, especially fibre friction and the short fibre content. The inter-fibre cohesion too has marked influence on the mass irregularity. The cohesion which is influenced by inter-fibre friction can be controlled through roving twist, spacer and the draft.

Short, small, thick, or thin places may sometimes be caused by excessive amplitude of the drafting wave at the spinning machine. Their origin is in the drafting elements, most likely of the spinning machine. Carding at high speeds can increase their frequency. Neps are often caused in carding, and the phenomenon is more pronounced with finer and immature fibres.

### *Hairiness*

Hairiness is a property which indicates the amount and length of fibre ends and loops protruding from the body of the yarn. It is a desirable property in certain situations and undesirable in other circumstances, depending upon the type of end-use and application of the resultant fabric. The hand and thermal insulation of textiles call for the most hairy yarn. On the other hand, high-speed knitting and weaving machines require a yarn structure in which protruding fibres are suppressed. An important consequence of the hairiness is the pilling of fabrics (Barella *et al.*, 1991). Yarn hairiness also influences the abrasion resistance of fabrics. Barella (1999) observed that the level of yarn hairiness depended on the number of fibres at the outer layer of the yarn that were not directly adhered to the body of the yarn. According to Wang *et al.* (1999), the looped hairs originate mainly from poorly aligned fibres, fibres with a U-shape or a large hook in the fibres, and the dynamic snap-back of fibres when during spinning they are suddenly released from the front roller nip of the drafting system. Mohamed *et al.* (1975) stated that fibre migration is responsible for the formation of looped hairs. Reducing the spinning triangle by increasing spinning tension may, however, reduce yarn hairiness (Stalder, 1991).

## 5.2.3 Factors affecting yarn properties

### *Fibre factors*

Although several experimental investigations concerning the strength and elongation of staple yarns have been reported in the literature, it is important to know the order in which the fibre and other parameters affect yarn strength, so that appropriate attention may be paid to these factors during the selection of the raw materials and processing parameters. As the yarn is composed of fibres, it is evident that the tenacity and elongation of fibres will have a pronounced effect on yarn strength and elongation. Stronger fibres will therefore always lead to a stronger yarn. Usually the strength translation efficiency

from fibre to yarn is 40–65%. The yarn elongation also depends upon fibre elongation. The yarn strength can be changed by altering the staple length of the fibres or by altering the fibre fineness. Increased fibre length leads to greater resistance to fibre slippage during yarn rupture, primarily because of longer overlapping lengths of fibres, and this causes an increase in strength. Finer fibres also increase the frictional resistance to slippage. The optimum twist level is reduced and the maximum strength is increased by increasing the staple length or the fibre fineness. This explains why a premium is placed on the longer staple fibres and why fine fibres are preferred for spinning. When fibres of similar nature are to be blended, their properties should be compatible especially in terms of length, fineness and elongation.

Yarn hairiness is another important quality attribute affected by the fibre parameters. Fibre fineness has the maximum influence on the hairiness, and is followed by fibre length. However, with cotton, maturity contributes very little towards hairiness. Using a heavier linear density increases the torsional stiffness of the fibre and makes it less likely that fibres will bend along with twist, resulting in increased hairiness.

#### *Yarn factors*

As the linear density of a yarn is reduced, the yarn strength is also reduced because of the lower number of fibres in the yarn cross-section. As explained earlier, high variations in the mass per unit length of slivers or rovings cause irregularities in the spun yarn and result in large variations in yarn strength. Proper selection of speeds of machine elements and adjustment of settings between various rotating parts and the optimization of twist will therefore ensure smooth processing and production of a good quality yarn.

#### *Machine factors*

Yarn hairiness can be regulated by selecting the ring frame draft and spindle speed. For a constant yarn count, hairiness increases with increase in these two factors. Increased spinning tension also increases yarn hairiness. High-production carding, chemical processing of fibres prior to spinning, poor ring frame conditions due to traveller flutter, and high levels of humidity can also cause excessive hairiness.

### 5.2.4 End uses of ring spun yarns

The ring spinning system can be used to produce very coarse to extremely fine yarns with a very large range of twist density from various types of fibres and their blends. Ring spun yarns can therefore be engineered to impart the desired hand, e.g. crispness or softness, to a fabric according to requirements.

Ring spun yarns are widely used for shirts, trousers, nightwear, blouses, overalls, suits, skirts, sheeting, curtaining and other industrial textiles.

## 5.3 Rotor spun yarns

### 5.3.1 Structural features of rotor spun yarns

#### *Surface structure*

Figure 5.3 depicts the surface structure of a rotor spun yarn. As can be seen, a rotor spun yarn consists essentially of a three-part structure, namely, a densely packed core of fibres that are substantially aligned with the axis of the yarn, an outer zone of more loosely packed fibres which occurs irregularly along the core length, and the fibres that are wrapped around the outside of the yarn to form wrapper fibres of very small inclination (Nield, 1975). A detailed study of the surface structure of rotor spun yarns (Lawrence and Finikopoulos, 1992) shows that the variation of surface appearance along the yarn length may be classified as indicated in Fig. 5.4. The number of wrapper fibres increases with rotor speed, reduced rotor diameter, reduced rotor groove angle, increased yarn count, fibre length and fibre linear density. The length of the yarn formation zone has a decisive effect on the incidence of wrapper fibres; the longer the zone, the greater is the incidence. Wrapper fibres improve yarn abrasion resistance but reduce the wicking property of the yarn. For both short and long staple yarns, an increase in wrapper fibres results in deterioration in yarn strength and yarn density in general.

#### *Migration*

In rotor spinning, fibre migration is partially caused by the twist in the rotor groove and the manner in which the fibres are deposited on the forming

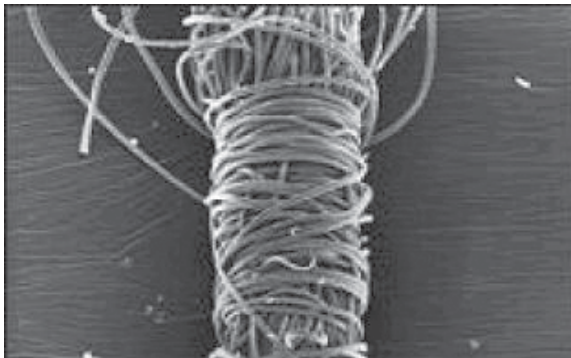

5.3 Rotor spun yarn surface structure.

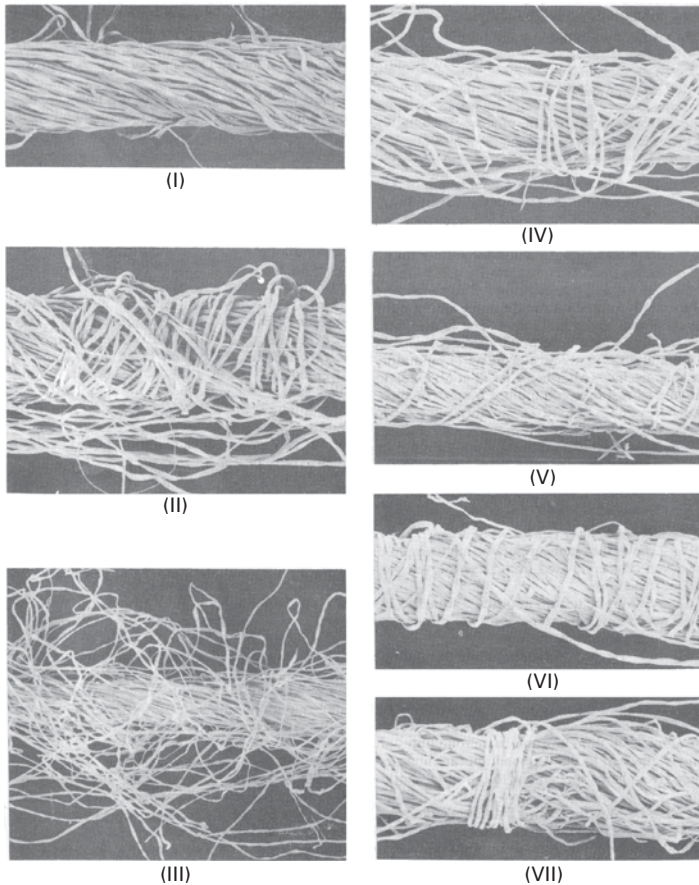

5.4 Scanning electron micrographs of rotor spun yarn surface structure: (I) ordered; (II) loosely wrapped; (III) hairy; (IV) multiple wrapped; (V) opposingly wrapped; (VI) tightly wrapped; and (VII) belt wrapped (Lawrence and Finikopulos, 1992).

yarn in the groove of the rotor. The fibre tensions in the rotor groove are much lower than those encountered in the delta zone of ring spinning. The result is that fibre migration is more local, as may be reflected by the lower values of the root-mean-square deviation. The root-mean-square deviation for a typical ring yarn is about 0.54, whereas it is only 0.44 for rotor yarn. If one looks at the mean fibre position in ring and rotor spun yarns, it would be seen that most of the migrating fibres in rotor yarn lie in the core. The preferential arrangement of fibre components in a blend is also lower for rotor than for ring spun yarns.

### *Twist deviation*

The twist of rotor spun yarns is in principle built up from the inside to the outside. Unlike for ring yarns, the measured twist values are lower than the machine twist values for rotor spun yarns, thus indicating that there is indeed fibre slippage during yarn formation within the rotor. This is an inevitable consequence of the system of yarn formation and is one of the reasons for the high machine twist setting requirements of rotor spun yarns. The difference between rotor and ring spun yarn can therefore be reduced only within certain limits by keeping the twist deviation as low as possible. The twist deviation is known to depend upon the rotor speed, the draw-off nozzle profile, and the speed of the opening roller (Manich *et al.*, 1986). These factors can be varied to avoid the danger of over-twisting. Yarn count, twist and blend level play a significant role in determining the amount of fibre slippage and, in consequence, the twist deviation. The heavier the yarn, or the greater the twist or the greater the polyester content, the greater the twist deviation (Lord and Grady, 1976). The fibre factors influencing twist deviation include fibre length, fineness, stiffness, finish and cross-sectional shape (Tyagi *et al.*, 2001).

### 5.3.2 Properties of rotor spun yarns

Rotor spun yarns appear to be no different from ring spun yarns on the surface. However, there exist some rather important differences in the internal structures of the yarns, especially in fibre contiguity. These differences in internal structures are reflected in different performance characteristics. Rotor spun yarns tend to be more uniform in appearance and in linear density than ring spun yarns. It is conceivable that the better short-term evenness of rotor spun yarn is an obvious result of the suppression of the drafting wave and the large packages formed in rotor spinning. Also, rotor spun yarns are known to be somewhat more extensible, fuller, softer and less hairy. The main disadvantage is that rotor spun yarns are not as strong as ring spun yarns, and the maximum tenacity of rotor spun yarns is at least 10–30%, and in some cases even up to 40%, lower than that of ring spun yarns. It is pointed out that although significant differences exist between rotor and ring spun yarns, various fibre factors and spinning conditions could greatly alter the properties of rotor spun yarns.

### 5.3.3 Factors affecting yarn properties

#### *Fibre parameters*

The choice of raw material plays a dominant role in controlling yarn quality in rotor spinning. There is a general consensus of opinion that the

raw material properties must be ranked in a different order of importance for rotor spinning than for ring spinning. The first significant raw material parameter controlling the characteristics of a rotor spun yarn is fibre fineness. Use of finer fibres for spinning rotor yarns provides several advantages such as increased spinning limit, more even yarn and lower optimum twist. Consequently, finer fibres should be preferred for rotor spinning than for ring spinning, the increase in the number of fibres in the yarn cross-section reducing strength loss due to poor fibre parallelization (Simpson and Murray, 1978). Another major parameter influencing rotor yarn quality is fibre strength. As expected, a stronger fibre yields a stronger yarn and therefore reduces the strength deficiency.

Fibre length characteristics, particularly length uniformity, play only a minor role in rotor spinning, and long fibres offer no advantage. Longer fibres can adversely affect yarn strength and evenness due to the greater incidence of wrapper fibres and poor fibre orientation (Kaushik *et al.*, 1987a).

### *Sliver quality*

The quality of feed sliver in terms of cleanliness, uniformity and orientation of fibres has a profound influence on end breaks in rotor spinning and consequently on the rotor yarn properties such as strength and irregularity. The requirements in so far as trash is concerned depend upon whether or not trash removal facilities are available on the rotor machine. Part of the trash left in the sliver reaches the rotor groove and accumulates there, leading to short-term irregularity and strength variation of the yarn and ultimately to end breakage. This accumulation rate obviously depends upon residual trash content in the sliver. Reportedly, the level of trash in the feed sliver should not exceed 0.2% (Hunter, 1978).

Sliver variations cause an uneven flow of fibres through the transport duct and their subsequent deposition in the rotor groove, which, in turn, results in yarn count variation and poor spinning performance. It needs to be mentioned that rotor spinning can compensate for inherent very short mass variation in the sliver due to the layered deposition of fibres in the rotor groove. The Uster CV% should be maintained between 2.5 and 3, for a 3 ktex sliver count, which is widely used in the spinning of rotor yarns.

It is important to maintain high fibre orientation in the drafted sliver, since this leads to a more ordered arrangement of fibres in the rotor groove, which facilitates easy flow of twist along the rotor periphery and improves spinning stability and yarn strength. Two drafting passages are therefore recommended to ensure fairly uniform sliver with adequate fibre parallelization (Tyagi *et al.*, 1999).

*Rotor machine variables*

While producing thick sliver, the question of high total draft inevitably crops up. Draft, referring to the ratio of input sliver linear density to that of the yarn, affects fibre orientation. Overall draft ratios between 160 and 170 are suitable under many of the conditions encountered in practice. Increasing total spinning draft leads to an increased end-breakage rate and deterioration in the tenacity, breaking elongation and uniformity of the spun yarn.

The opening roller is a key parameter influencing rotor spun yarn characteristics. It individualizes the fibres and thereby assists in feeding them to the rotor. There is a practical limit to the opening roller speed for each type of opening roller covering and fibre type. Too low a speed results in inadequate fibre separation, whereas too high a speed leads to excessive fibre breakage and a decrease in yarn strength and breaking elongation (Hunter, 1978). The use of an opening roller covering with too severe an action can also cause a significant reduction in yarn tenacity as a result of fibre breakage.

The rotor diameter is normally chosen in relation to the length of fibres to be spun. Smaller diameter rotors result in lower power consumption and lower yarn tension, but impair yarn formation and lead to yarn irregularity and end-breakages. The width of the rotor groove has a marked influence on the strength of rotor spun yarns, and a large, open and self-cleaning rotor groove is preferable for coarse yarns. The maximum attainable rotor speed on a particular rotor spinning machine is a function of the design and diameter of the rotor, the yarn strength and its variability. With increasing rotor speed, throughput rate increases, which in turn affects fibre separation by the opening roller, leading to poor fibre orientation and high short-term yarn variability. High rotor speeds demand high twist coefficients to maintain spinning stability, resulting in a yarn of higher stiffness.

In discussing the structure and properties of rotor yarns, particularly with regard to the wrapper-fibre surface structure, it is appropriate to consider the influences of the doffing tube navel design on the frequency of wrapper fibres and on other yarn characteristics. It is generally agreed that a grooved doffing tube enables lower twists to be used, but such doffing tubes often adversely affect the yarn characteristics and give a rougher yarn surface. Studies have shown that changes in doffing tube design effect changes in the frequency of certain classes of wrapped structures and in a number of the measured parameters defining the handle of knitted fabrics (Lawrence and Finikopulos, 1992). The details of the doffing tube navels and the measured yarn properties are shown in Tables 5.2 and 5.3 respectively. The tensile properties of the yarns and the number of thick places, thin places and neps remained unaffected by the doffing tube navels. However, the irregularity and hairiness increased as the navel became more grooved (Lawrence and Finikopulos, 1992).

Table 5.2 Changes in doffing tube parameters

Nozzle type	$D$ (mm)	$d$ (mm)	$R$ (mm)	$H$ (mm)	$x$ (deg)	Features
<i>Ceramic</i>						
CSMO	17.0	2.5	6.2	4.0	30	Smooth
CSPI	16.5	2.5	7.0	3.9	30	Spiral
C4NO	15.4	2.5	7.0	4.0	30	4 notches
C6NO	16.5	2.5	7.0	3.9	30	6 notches
<i>Steel</i>						
SSMO	17.0	2.5	7.0	4.0	30	Smooth
S4NO	17.0	2.5	3.5	4.0	30	4 notches
S6NO	17.0	2.5	3.5	4.0	30	6 notches

$D$  = outer diameter,  $d$  = bore;  $R$  = base radius;  $H$  = flange thickness,  $x$  = inclination of groove.

Source: Lawrence and Finikopulos (1992).

Table 5.3 Measured yarn properties

Property	Doffing tube						
	CSMO	CSPI	C4NO	C6NO	SSMO	S4NO	S6NO
Irregularity (U%)	8.8	9.5	10.1	10.9	9.0	9.8	10.6
Neps (+280%)	0	0	0	1.0	0	0	1.0
Thin places (-50%)	0	0	0	0	1.0	0	1.0
Thick places (+50%)	3.0	3.0	2.0	2.0	3.0	3.0	2.0
<i>Hairiness</i>							
H (Uster value)	4.0	4.5	4.8	5.0	4.5	5.1	5.6
CV% (Uster value)	1.1	1.2	1.2	1.2	1.2	1.3	1.5
Tenacity (cN/tex)	12.7	12.4	12.6	12.5	12.6	12.5	12.4
CV%	5.2	5.1	5.2	5.1	5.3	5.3	5.2
Extension (%)	6.6	6.5	6.4	6.6	6.7	6.5	6.4

Source: Lawrence and Finikopulos (1992).

### 5.3.4 Rotor spinning of synthetic fibres and blends

#### *The choice of raw material*

The major fibre properties that influence yarn quality in rotor spinning are fibre tenacity, fineness and length. High tenacity fibres should normally be preferred so as to reduce the strength deficiency of rotor spun yarns, end-breakages and fibrous rotor deposits attributable to the aggressive action of the opening roller. Fibre linear density affects the number of fibres in the yarn cross-section. The use of finer fibres for spinning rotor yarns offers considerable advantages in respect of spinning limit and yarn regularity. Further advantages are the ability to reduce yarn twist and increase breaking tenacity. However, as fine fibres are more prone to damage, the optimum

fibre linear density per filament for rotor spinning seems to be 1.67 dtex, and the optimum fibre length has been found to be 32 mm for man-made fibres (Salhotra, 1992). Shorter fibres not only favour higher rotor speeds due to the smaller rotor required, but also improve yarn strength and evenness due to a distinct decrease in the number of wrappers.

The fibre cross-sectional shape is also an important variable. Technically speaking, modification of the cross-section of the fibre allows engineering of the surface properties of yarns and fabrics. However, in rotor spinning, the use of non-circular fibres offers no technical advantage as far as yarn quality is concerned. Published data have shown that yarns produced with a trilobal polyester fibre perform no better than yarns made from a circular fibre in respect of twist deviation, tensile properties and mass irregularity (Tyagi *et al.*, 2002).

Mechanical crimping has been found to be useful to facilitate processing of man-made fibres during various stages of spinning. The crimp introduced, however, is lost in the ensuing processing stages prior to spinning due to lack of durability. Higher crimp also has a deleterious effect on yarn quality. The fibre crimp, therefore, needs to be examined for its level and permanence. A lower fibre crimp yields better results. The arcs per centimetre should lie between 3.5 and 5 for polyester fibre (Salhotra, 1992).

Another important aspect of synthetic fibre characteristics, which is of direct relevance to spinners, is surface finish. Fibres generally spin better with the right finish than without any finish. It is now recognized that spin finish can lead to incomplete opening if the fibre contains a high lubricant level. However, fibres with too low a lubricant level also cause trouble with rotor deposits. It should be pointed out that polyester fibre with a lubricant level slightly lower than that often required for ring spinning performs well during spinning on rotor spinning machines. Generally, an addition of 0.05–0.1% antistatic agent is recommended for rotor spinning (Ishtiaque, 1992).

Rotor spinning appears to be more restrictive than ring spinning with regard to the inclusion of inorganic pigments in synthetic fibres as they cause severe wear of rotors and opening rollers. The delustrant  $\text{TiO}_2$  added to fibres meant for rotor spinning should be less than that normally used for ring spinning and a value of 0.1% seems to be the optimum.

### *Sliver requirements*

The important issue here is the yarn blend. With blended yarns, although the uniformity of fibre proportions along the yarn is one of the blend's important features, the homogeneity of the blend constituents is equally important. Homogeneous blending needs a randomized distribution of fibres in a cross-section through careful mixing and an optimized number of doublings in the drafting passages. Blending techniques form an important basis for rotor yarn

characteristics. Both flock-blending and draft-sliver blending can be used for blending, say, polyester and cotton fibres; the choice of blending technique depends on whether the cotton component used is carded or combed. There is sufficient experimental evidence to suggest that use of combed cotton instead of carded cotton does not improve yarn strength, clearing doubt as to whether the carded cotton can be used in general as a replacement for combed cotton. However, in the case of draft-sliver blending, an autolevelling at card is to be followed by two or three stages of drawing.

### *The choice of rotor machine variables*

Many investigations into the influence of processing parameters on yarn quality, when rotor spinning of man-made fibres and their blends has been carried out, and a comprehensive review can be found in the publication by Lawrence and Chen (1984). The main problem in spinning synthetic fibres and their blends is to separate the fibres without creating hooks on the fibres or damaging them. There is an optimum opening roller speed for each roller covering and fibre. Opening roller speeds are kept somewhat higher for synthetic fibres than for cotton but excessively high speeds can damage the fibres. The widely recommended opening roller speeds for synthetic fibres and blends vary from 6000 to 7000 revolutions per minute.

The type of opening roller used is responsible for spinning performance and the resulting yarn properties. Most synthetic fibres are best processed with an opening-wire front angle between  $90^\circ$  and  $100^\circ$ , and a relatively lower density of 5–9 teeth per square centimetre. The opening-wire front angle on the opening roller for acrylic and viscose fibres is adequate when close to  $90^\circ$ , and a roller with  $99^\circ$  front angle gives good separation for polyester fibre (Vigo and Barella, 1981).

Higher rotor speeds are necessary to make the rotor operation more economically attractive, but this introduces its own technical complications. The essential criterion for the level of speed to be used is the thread tension, which is largely governed by the rotation of the thread-end in the rotor; its absolute value is dependent upon the yarn fineness as the mass has a linear influence on the centrifugal force. It is therefore useful to express the thread tension as a specific value in relation to the yarn linear density. An absolute spinning limit is considered to be approximately 2 cN per tex (Artzt *et al.*, 1992). In practice, it is recommended to use smaller rotors for spinning yarns at higher rotor speeds. However, experiments have shown that the zone with optimum spinning stability is not the zone for best possible yarn quality. Every rotor diameter must therefore be assessed separately with respect to its speed zones.

Another factor relevant to rotor spinning is that the rotor diameter must be in a certain ratio to the fibre length. The stability of the spinning process

as well as the yarn structure is dependent on this ratio. The ratio of rotor diameter to fibre length should be 0.9–1.0 (Artzt *et al.*, 1992).

Yarn formation and quality are greatly influenced by the design of the doffing tube and the twist index. In general, smooth doffing tubes are preferred for spinning man-made fibres on rotor spinning machines. It may be noted, however, that the selection of twist is based more on the criterion of spinning stability rather than producing a strong yarn. Invariably, low twist factors are recommended for man-made fibre rotor spun yarns than for all-cotton yarns of equivalent linear density (Barella *et al.*, 1980), and the values of twist close to 140 (turns per metre) $\text{tex}^{1/2}$  have been found to be optimum for polyester fibre yarns, about 120 for acrylic fibres and below 120 for viscose yarns (Barella and Vigo, 1980).

### 5.3.5 End uses of rotor spun yarns

Rotor spinning can be employed to spin good quality yarns of 18–200 tex from cotton, polyester blends, viscose rayon and acrylic fibres. From microfibres, it is now quite possible to spin yarns down to 10 tex (Ernst, 1993). The products for which rotor spun yarns are considered particularly suitable include dress materials, denim and jeans, sheeting, leisure wear, industrial wear, interlining, towels, furnishings and warp knits.

## 5.4 Air-jet spun yarns

### 5.4.1 Structural features of air-jet spun yarns

#### *Classification*

The air-jet spun yarn, also termed a fasciated yarn, is composed of a central core of essentially parallel fibres bound together by wrappers, and has many distinctive recurring features in wrapping along the yarn length. Several different classification systems have been applied to air-jet spun yarns but the system suggested by Basu (1991) has been greatly acknowledged. The classification which was used to quantify the various structural components along the yarn length was as follows:

- Class 1: those parts of the yarn which have a regular helical wrapping and in which the core is crimped
- Class 2: those parts which have no wrapping fibres and possess the appearance of a low-twisted yarn
- Class 3: those parts of the yarn which have a straight yarn core regularly bound with wrapper fibres
- Class 4: those parts of the yarn which have a straight yarn core bound by irregular wrapper fibres.

The average length of the wrapped structure was found to be different for different yarns made from different materials. In another study, Lawrence and Baqui (1991) classified the yarn structure into three groups, as orderly wrapped, randomly wrapped and unwrapped section (Fig. 5.5). Chasmawala *et al.* (1990) described the yarn structure as essentially that of a comparatively straight central core of fibres held together by taught surface fibres wound helically onto the central core. They reported five different configurations of fibres in the yarn, namely core, wrappers, wild, core–wild and wrapper–wild.

### *Migration*

In air-jet spinning, there is considerable variability in wrapper fibre configuration, with some wrapper fibres wrapping in both the S and Z directions. The homogeneity of the structure and the interlocking of individual fibres through migration is absent in air-jet spun yarns, and this is partly responsible for their lower strength. The fibre packing density is non-uniform throughout the yarn cross-section, with fibres mostly packed nearer the yarn core (Ishtiaque and Khare, 1993). Attempts have been made to relate yarn properties to yarn internal structure in terms of the fibre extent (Punj *et al.*, 1997). The extent of short wrappers, long wrappers and migrated core fibres in viscose air-jet yarns may be dependent on fibre type as these structural characteristics were found to be more prevalent than in polyester air-jet yarns. The fibre extent varies with second nozzle pressure and production speed. Alteration in yarn structural properties occurs with changes in fibre type, and therefore with composition of the fibre blends and production speed (Tyagi and Doshi, 2006). Under all experimental conditions reported, polyester–viscose yarns exhibited more wrappers and wraps per centimetre, larger helix angles and larger helix diameters than polyester–cotton yarns. For both blends, each of these parameters showed an ascending relationship when both the polyester content and the spinning speed increased.

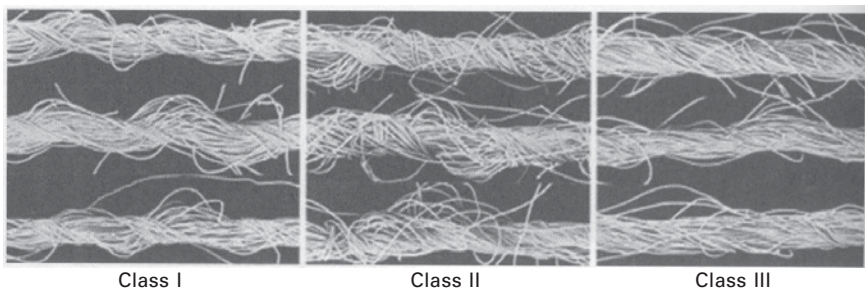

5.5 Air-jet spun yarn surface structure (Lawrence and Baqui, 1991).

## 5.4.2 Properties of air-jet spun yarns

There are many marked differences between the properties of air-jet spun yarns and those of ring spun yarns owing to differences in fibre configuration within the yarn and the yarn structure. Air-jet spun yarn strength ranges from weaker to much weaker than ring spun yarn strength, depending upon the fibre used. The tenacity value of cotton air-jet spun yarn is 50–60% of that of similar ring spun yarn; this increases to 80–85% for polyester or polyester-cotton blended yarn (Stalder, 1990). In comparison with ring spun yarns, air-jet spun yarns have higher bending rigidity, are less hairy, more even, have fewer neps, slubs and thick and thin places, and have lower abrasion resistance: see Table 5.4. Air-jet spun yarns produced with polyester fibre in blends with either viscose or cotton fibres possess better structural integrity, lower compression energy and better compression resilience than the corresponding ring spun yarns from the same fibre types (Tyagi *et al.*, 2007).

## 5.4.3 Factors influencing the properties of air-jet spun yarns

### *Fibre parameters*

The fibre properties that are thought to have a marked influence on the properties and performance characteristics of air-jet spun yarns are (1) fineness, (2) fibre length, (3) strength, and (4) inter-fibre friction. As the number of fibres in the cross-section of an air-jet spun yarn has to be greater than that for the corresponding ring spun yarn, finer fibres should be preferred. Air-jet spun yarns produced from fine fibres have considerably higher strength, lower rigidity and higher elastic recovery (Kaushik *et al.*, 1993). It may be noted, however, that using fine polyester fibre in a polyester–cotton blend enables increased production speeds without significant loss in yarn strength and unevenness, but may cause considerable deterioration in yarn imperfections and hairiness (Bhortakke *et al.*, 1997). Fine fibres are prone to nep generation, therefore the most suitable fibre linear density for air-jet spinning appears to be 1.3 dtex.

The fact that strong fibres produce strong yarn also holds true for air-jet spun yarns. Nevertheless, in the case of polyester, fibre tenacities beyond 7 grams per denier offer no additional advantage for yarn strength. Such high strength fibres have lower elongation, and wrappers formed by less extensible fibres cannot hold the core fibres with a tight grip for a longer period when the yarn goes through stress. Hence, fibre strength should always be considered along with fibre elongation which should be high enough to generate wrapping-compression (Salhotra, 1992).

Table 5.4 Influence of fibre profile and spinning speed on performance properties of polyester–viscose and polyester–cotton ring and MJS yarns

	Fibre profile	% Decay				Compressional energy (%)				Compressional resiliency (%)			
		Ring yarn	MJS yarn			Ring yarn	MJS yarn			Ring yarn	MJS yarn		
			160 <sup>a</sup>	180 <sup>a</sup>	200 <sup>a</sup>		160 <sup>a</sup>	180 <sup>a</sup>	200 <sup>a</sup>		160 <sup>a</sup>	180 <sup>a</sup>	200 <sup>a</sup>
Polyester–viscose (65:35)	Circular	48.1	37.8	36.6	33.5	1.27	1.24	1.22	1.12	56.1	57.6	60.2	65.0
	Trilobal	49.7	41.5	40.9	39.0	1.29	1.26	1.24	1.18	51.0	53.2	54.4	63.8
Polyester–viscose (48:52)	Circular	50.8	42.7	40.8	38.9	1.24	1.21	1.19	1.14	58.2	59.3	61.0	68.5
	Trilobal	52.0	43.6	42.5	40.6	1.28	1.23	1.21	1.16	54.1	55.2	57.2	66.5
Polyester–cotton (65:35)	Circular	54.3	42.0	40.6	38.9	1.30	1.29	1.26	1.18	44.5	47.0	47.2	64.2
	Trilobal	56.1	43.5	41.5	40.1	1.34	1.30	1.28	1.20	43.0	44.2	45.8	62.8
Polyester–cotton (48:52)	Circular	55.1	43.8	41.9	40.8	1.26	1.25	1.22	1.15	45.5	46.8	48.6	64.7
	Trilobal	57.0	44.9	43.2	42.0	1.30	1.27	1.25	1.18	42.4	43.2	45.0	63.8

<sup>a</sup> Production speed, m/min.

Source: Tyagi *et al.* (2007).

Fibre length is very important to the properties of fasciated yarns, more so than for twisted yarns (Santjer, 1991). Longer fibres can be wound around the yarn core a greater number of times with the same angle of wrap, and thus can securely hold the fibre bundle. However, looking at the problems encountered in processing long fibres at the card, it is preferable to use fibres of 38 mm for polyester–cotton blends, whereas for polyester–viscose blends the staple length should be about 44 mm.

Air-jet spun yarn strength depends very much on inter-fibre friction. Higher inter-fibre cohesion results in reduced end breaks and improved yarn strength. With synthetic fibres, particularly polyester, it is essential that the fibre has a non-depositing finish because such fibre finishes cause undesirable nozzle deposits. Sliver fed to the air-jet spinner should not contain fibre aggregate, particularly cotton fibres, as these would hinder the rotation of forming yarn in the narrower tube of the air jets and lead to interruption in twist insertion.

### *Process parameters*

In order to produce a sufficiently strong yarn, it is important for the highest number of wrapper fibres to be available in the yarn structure. The first nozzle pressure has great influence in this respect. With a twin-jet system, an increase in the first nozzle pressure, up to a critical value, was found to improve the tenacity and breaking elongation for polyester–viscose blended yarns (Punj *et al.*, 1997). The same effect was seen for the flexural rigidity, but the evenness of the yarn was distinctly reduced. Beyond the critical value, an increase in first nozzle pressure decreases the yarn tenacity. Similar studies by Tyagi and Salhotra (1996a) showed this critical value for the first nozzle to be above 3 kilograms per square centimetre. An increase in second nozzle pressure increases the yarn tenacity, breaking elongation and flexural rigidity and results in an increase in the percentage of tight wrappers and wrapper extent (Punj *et al.*, 1997). With regard to yarn tenacity there is an interaction between first nozzle and second nozzle pressures (Rajamanickam *et al.*, 1998). This is because for a given first nozzle pressure the total number of wrapper fibres in a given yarn section and the length of the wrappings depend on the level of second nozzle pressure, and vice versa. Thus, the optimum number of wrapper fibres and wrapping lengths can be obtained with various combinations of nozzle pressures.

Production speed is another parameter influencing air-jet spinning. As this is increased, the yarn strength goes up but the number of thick places and neps becomes higher (Lawrence and Baqui, 1991). In fact, increased air flow at high speed causes the edge fibres to move away from the fibrous strand and assists these fibres to become long wrappings. However, in another study (Wang, 1987), the yarn strength improved with increase in production

speed up to certain level, after which it deteriorated. It can therefore be said that the optimum speed does not yield the best value for all the yarn characteristics.

In air-jet spinning, the main draft is a highly significant factor for breaking load, breaking elongation and hairiness. Draft affects fibre orientation and its influence is greater at high production speeds. The preliminary draft and main draft also depend on the amount of draft. Higher main drafts give higher strength, higher breaking elongation, abrasion resistance and flexural rigidity. The number of thick places and neps rises sharply with an increase in main draft. It is claimed that a main draft of about 35 is applicable to many of the process requirements encountered in practice (Tyagi *et al.*, 2003).

The size of the condenser controls the width of the sliver in the main drafting zone. In one study (Tyagi and Salhotra, 1996a), the most significant difference found between yarns spun with 3 and 5 mm condensers was the number of wrapper fibres. The wider condenser produced a yarn that was less uniform and more rigid, had better strength and breaking elongation, and had higher imperfection indices than the narrower condenser. In contrast, Kampl and Leitner (1989) suggested that minor improvement of the yarn tensile properties can be achieved by using a narrower condenser.

Tyagi and Salhotra (1996b) studied the quality aspects of increasing the feed ratio and the distance between the first nozzle and the nip of the front roller on an air-jet spinning machine. It appears that, in general, increasing the feed ratio causes an improvement in yarn breaking strength, breaking elongation, uniformity and the frequency of imperfections. The flexural rigidity also increases dramatically at high feed ratios. Surprisingly, however, changing the distance between the first nozzle and the nip of the front roller hardly affects the yarn tenacity and breaking elongation, although a wider gap between the first nozzle and the nip of the front roller results in enhanced uniformity and flexural rigidity (Table 5.5). The implications of differences in the feed ratio on the structural and characteristic variations of acrylic air-jet spun yarns have also been considered by Lawrence and Baqui (1991). With increase in feed ratio, the frequency and average length of loosely wrapped portions and unwrapped portions reduce, whereas the frequency and average length of tightly wrapped portions increase. The yarn tenacity and elongation showed marginal increases.

#### 5.4.4 End uses of air-jet spun yarns

Air-jet spun yarns are used extensively for bed linens, shirting, overcoat fabrics, dress materials, knitted goods, home furnishings and some industrial applications.

*Table 5.5* Characteristic variations in jet-spun yarns

Feed ratio	Ribbon width (mm)	Tenacity (mN/tex)		Breaking extension (%)		Unevenness (U%)		Flexural rigidity × 10 <sup>3</sup> (g.cm <sup>2</sup> )	
		38 <sup>a</sup>	41 <sup>a</sup>	38 <sup>a</sup>	41 <sup>a</sup>	38 <sup>a</sup>	41 <sup>a</sup>	38 <sup>a</sup>	41 <sup>a</sup>
0.96	3	146.8	151.1	12.8	13.5	11.9	11.4	10.5	11.6
0.97	3	152.9	158.3	13.4	13.8	11.2	10.5	11.0	12.1
0.98	3	159.7	165.4	13.8	14.1	10.7	10.2	11.6	12.6
0.96	4	151.6	157.2	13.4	13.8	12.5	12.0	10.8	12.1
0.97	4	157.6	163.6	13.7	14.2	11.8	11.5	11.2	12.5
0.98	4	164.4	170.2	14.2	14.6	11.6	10.3	11.8	13.0

<sup>a</sup>Distance between the first nozzle and the nip of the front roller.  
Source: Tyagi and Salhotra (1996b).

## 5.5 Friction spun yarns

### 5.5.1 Structural features of friction spun yarns

#### *Surface structure*

A friction spun yarn visually appears to be more like a ring spun yarn than an open-end rotor spun yarn but its internal structure differs from both, as can be seen from Fig. 5.6. It is characterized by inferior fibre orientation, buckled and folded fibre configurations and loose packing of fibres. A Dref-3 friction spun yarn consists of a two-part structure, namely a densely packed core containing both straight and twisted fibres that are randomly distributed along the yarn length, and the fibres that are wrapped helically over the core to form a sheath and that exhibit Z-twist (Gowda, 2001). Several fibres have their leading end hooked, whereas the trailing end is almost free from any hook. The average fibre extent for core fibres is about 32 mm for Dref-3 spun yarns produced from 38 mm and 1.65 dtex acrylic fibres, the figure being 19 mm for the sheath fibres. The packing density is highest at the core and decreases towards the surface (Tyagi *et al.*, 2000).

#### *Migration*

In friction spinning, the fibres are applied more or less one at a time without the required cyclic differentials in tension. Also, the principal tension occurs only after the yarn structure is already produced, and the tensions acting on the fibres during assembly are likely to be extremely low. These small tension variations may result in some fibre migration, but only to a small degree. As the fibres are fed to the yarn tail without tension and lie along the yarn tail at necessarily different radial positions, they occupy different radial positions, exhibiting a layered structure (Fig. 5.7). However, many technologists have different opinions about the occurrence of migration in friction spun yarns. Rust and Lord (1991) showed that the fibres in the friction spinning process

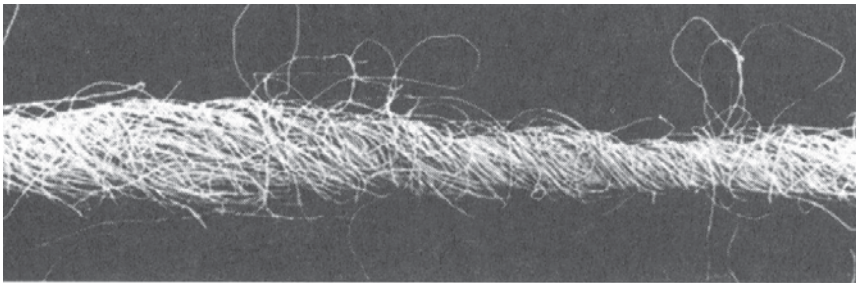

5.6 Dref-2 friction spun yarn surface structure.

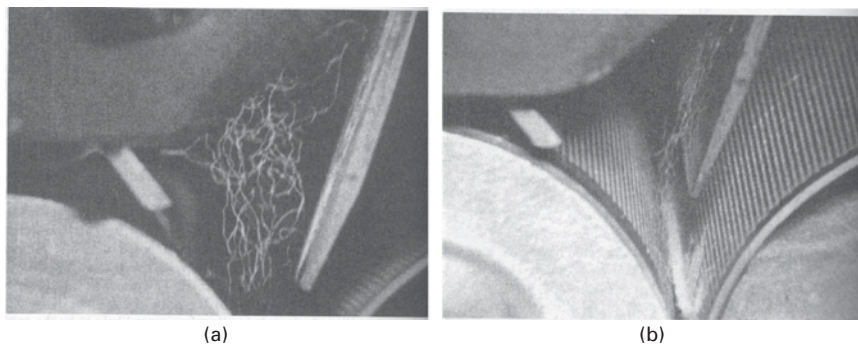

5.7 Yarn formation on Dref-2 friction spinner: (a) fibre movement from the opening roller to the friction drums; (b) fibre lending and twisting.

move inwards radially towards the apex of the cone as they are assembled into the yarn. In another study by Alagha *et al.* (1994), the amplitude of migration was found to be highest for friction spun yarns, followed by rotor- and ring spun yarns. On the other hand, Lunenschloss *et al.* (1986) found a stronger migration friction spun yarns than for ring spun yarns.

### *Twist structure*

When a fibre is wrapped about the core with a constant yarn axial velocity and constant rotational speed, the pitch remains constant, but the fibre helix angle increases as a function of the radial position. In fact, because the diameter of the yarn tail along the yarn axis varies in the yarn-forming zone, each point of the yarn turns with a different rotational speed, which is faster in the nip of the yarn tail. This produces a differential twist distribution in the inner and outer layers, and the twist in the yarn centre is 2–2.5 times higher than the twist in the surface (Rust and Lord, 1991). With some friction spinning systems several slivers are fed together, side-by-side, to the friction twisting zone. Fibres are therefore fed from different feed positions, and their location in the multiple sliver feed determines their subsequent location in the yarn structure. For example, it was found that in staple-core Dref-3 friction spun yarns with a core–sheath ratio of 70:30, the helix angle and helix diameter of sheath fibres reduced progressively from the position nearest to the delivery end to that farthest from the delivery end. However, the twist remained essentially the same irrespective of the sliver position (Gowda, 2001). On the other hand, in continuous-filament core Dref-2 yarns spun with a core–sheath ratio of 30:70, the structural parameters of the sheath fibres from the different sliver positions are different, indicating that the surface character of the core influences the wrapping of sheath fibres.

### 5.5.2 Properties of friction spun yarns

Many studies concerning the properties of yarns made by different spinning systems have appeared in the literature in the past few years. However, their findings cannot be generalized as these studies differed in terms of raw material characteristics, machine versions and spinning conditions used. In general, friction spun yarns have 60–75% strength, 60–90% unevenness, 100–140% bulk and require 75–100% of the minimum number of fibres in the yarn cross-section as compared with the corresponding ring spun yarns (Deussen, 1989). In respect of yarn-to-metal friction, ring spun yarns exhibit the highest friction, followed by rotor and friction spun yarns for cotton and viscose fibres. However, with polyester fibres, friction spun yarns show the highest value, followed by rotor and ring spun yarns (Chattopadhyay and Banerjee, 1997). Also, friction spun yarns are inferior in terms of strength variability, imperfections and hairiness. Nevertheless, the best yarn appearance is obtained for Dref-3 yarns followed by ring and rotor spun yarns (Louis *et al.*, 1985).

### 5.5.3 Factors affecting yarn properties

#### *Machine parameters*

There appears to be general agreement concerning the functioning of the opening roller. Problems involved here include fibre damage, fibre doffing, and preservation of consistent yarn quality due to larger tuft size. Most opening rollers are covered with garnet-wire or needle-pins to cope with the high throughput, and it is claimed that spiral winding of the clothing on the opening roller results in excellent opening of fibres. The opening roller design and the opening roller speed greatly affect the spinning performance. Many researchers have investigated the effect of opening roller speed on yarn properties using different raw materials, spinning conditions and ranges of speed. The results of these studies, however, led to contradictory conclusions. Saad and Sherouf (1989) found an increase in yarn specific tension and breaking elongation for cotton and polyester–cotton yarns but no change in yarn tenacity with the opening roller speed increasing from 3500–5000 rev min<sup>-1</sup>. According to Ulku *et al.* (1995), an increase in opening roller speed has no effect on the fibre tenacity and elongation at break. However, a high level of fibre damage, differing from one sort of material to another, is caused by the high opening roller speeds, which leads to a deterioration in yarn quality, mainly in terms of tenacity, elongation, unevenness and imperfections.

The quality of friction spun yarns depends essentially on the arrangement for feeding fibre to the twisting element. Generally, a direct comber-roller feed results in a greater fibre extent and therefore a higher yarn tenacity and

elongation than the indirect feed method in which the fibres are first accumulated on the ingoing roll and then transferred to the nip (Rust and Lord, 1991). With regard to the transport-duct angle, a 30° angle produces the strongest yarn, and an increase in the angle of inclination leads to a decrease in yarn strength. The position of the mouth of the duct relative to the friction drum is also important. Increasing the distance between the duct and the solid friction drum increases the amount of air passing against the yarn end. As a result, air force acting on the fibre assembly owing to air flow increase, which, in turn, raises the level of yarn tension (Stalder and Soliman, 1987).

### *Process parameters*

The speed of the spinning drums is one of the key process variables that influence the yarn twist. For a given friction ratio, a higher spinning speed causes greater fibre buckling and a deterioration in yarn properties, particularly in irregularity and tenacity (Tyagi *et al.*, 1995). In case of Dref-3 cotton yarns, the tenacity increases with an increase in the speed of the friction drum from 3000 to 5000 rev min<sup>-1</sup>, although other yarn properties remain virtually unchanged (Padmanabhan and Ramakrishnan, 1993).

Importantly, the twist in friction spun yarns is controlled by the friction ratio, and the ratio of the friction drum surface speed to the yarn delivery rate has to be adjusted according to the fibre and mode of yarn formation used. It was found that for polyester spun by the Dref-3 system, an increase in the friction ratio resulted in a large increase in tenacity, breaking elongation, flexural rigidity, abrasion resistance and packing density of polyester Dref-3 yarns (Tyagi *et al.*, 2000). Friction spinning has a large potential for increasing delivery rate. However, higher delivery speeds are detrimental to the mechanical properties of polyester Dref-3 friction spun yarns (Tyagi and Khanna, 2005).

Suction pressure is another factor influencing friction spinning. A high air suction gives a high restraining force on the fibre assembly so that it will be pressed more firmly against the surface of the friction drums. This leads to increased friction between the two and an increased amount of torque acting on the surface of the fibre assembly. Consequently, yarn twist, tension and twisting efficiency tend to increase. An increase in suction pressure is also accompanied by an increase in airflow and therefore in mean fibre speeds in the fibre transport tube. This facilitates fibre orientation inside the tube and thus improves yarn tenacity, appearance and evenness and reduces the yarn diameter (Konda *et al.*, 1996).

The core–sheath ratio has a considerable influence on the properties of polyester friction spun yarns. Generally, yarns produced with a thicker core are significantly stronger and less extensible, and have a higher work of rupture and higher abrasion resistance than the equivalent yarns produced

with the thinner core. This critical core content depends on the fibre fineness and profile (Tyagi and Khanna, 2005). For 100% cotton, it is comparatively difficult to produce Dref-3 yarns with a 50:50 core–sheath ratio (Louis *et al.*, 1985). The maximum strength is achieved with 70% core fibres and 30% sheath fibres (Padmanabhan and Ramakrishnan, 1993).

Another system-dependent parameter is spinning tension. A higher spinning tension results in a compact structure. A lower tension, on the other hand, reduces the end-breakage rate but results in lower yarn strength owing to insufficient friction between the fibres. As mentioned earlier, the tension is relatively low in friction spinning, and depends on the size of the force on the yarn tail generated by the air flow, as well as the friction coefficients of the spinning drums, the yarn diameter and the yarn tail diameter. In the case of filament-core yarns, the pretensioning of the filament core is an important factor. The level of pretension affects the configuration of the filament in the core and the other structural elements and consequently the mechanical properties of the spun yarns.

### *Fibre factors*

The twisting rate in friction spinning is largely dependent upon the friction between the fibres and the drum surface. Therefore, a high friction between the fibres and the friction drum surface is desirable. The inter-fibre friction should also be high as the parallel-fibre core needs to be properly bound to resist slippage. Thermoplastic fibres are produced with a spin finish applied to their surface to make them amenable to further processing. It is believed that spin finishes, or generally lubricating additives, affect the deformability of fibres during twisting because of decreased friction between the fibres. An increase in the level of spin finish would cause low frictional resistance between the fibres and the friction drum, and thus would prevent them from being twisted as desired. This could then result in decreased yarn strength, abrasion resistance and structural integrity (Sengupta *et al.*, 1992).

The properties of the constituent fibres would also affect such factors as fibre-strength utilization, the propensity to fibre damage and the twist insertion during friction spinning. It has been reported (Louis *et al.*, 1985) that about 74% of the strength of 74 tex cotton Dref-3 yarn is accounted for by fibre length, strength, elongation and micronaire, as against 94% in ring spun yarns. The number of fibres in a given yarn cross-section depends on the individual fibre denier. As the minimum number of fibres required in friction spinning is higher than for ring spinning, fine denier fibres are required for the medium to fine count range. The yarn twist increases directly with fibre fineness. This is because the depositing fibres are pressed more firmly into the wedge of the friction drums, resulting in a smaller sleeve. Thus the use of finer fibres offers considerable advantage in friction spinning in respect of

yarn strength, breaking elongation, abrasion resistance and rigidity. However, fine fibres are more prone to damage during opening and carding.

The fibre length requirement in friction spinning is similar to that in rotor spinning, in that yarns spun from longer fibres are stronger and more extensible (Louis *et al.*, 1985). However, longer fibres are more susceptible to damage, and have a tendency to lap around the opening roller.

Synthetic fibres can be produced with various cross-sectional shapes, such as circular, trilobal and triangular. Trilobal fibres are not regarded as suitable for friction spinning (Tyagi and Khanna, 2005). In general, trilobal fibre yarns exhibit lower strength, lower abrasion resistance and higher flexural rigidity than the equivalent yarns made from a circular fibre (Table 5.6).

#### 5.5.4 End uses of friction yarns

Generally, friction spinning can be used to spin yarns from cotton, polyester, acrylic, most fibre blends and recycled fibres. The yarns can be used for knitted goods, terry towel, weft and pile yarns, velvet and blankets. Some other applications include carpet backings, warping cloths, outer door textiles, protective textiles and filters.

### 5.6 Wrap spun yarns

#### 5.6.1 Properties of wrap spun yarns

The wrap spinning process produces yarns which are structurally somewhat similar to air-jet yarns (Fig. 5.8). The important difference is that the wrapping of the core fibres is by a filament yarn and not by staple fibres as in the air-jet spinning process. Wrap spinning technology, therefore, offers many advantages such as higher productivity, higher yarn tenacity and uniformity, less hairiness, the possibility of using coarse fibres for finer yarns, and greater covering ability in woven and knitted fabric structures.

Table 5.6 Structural and mechanical parameters of polyester Dref-3 yarns

Core-wrapper ratio	50/50 <sup>a</sup>	60/40 <sup>a</sup>	70/30 <sup>a</sup>
Helix diameter (1/100 mm)	36.7 (38.4)	34.5 (34.8)	33.9 (34.2)
Helix angle (degrees)	33.3 (34.3)	34.0 (35.3)	34.8 (37.4)
Twist (turns/m)	308 (354)	222 (294)	172 (255)
Fibre extent (mm)	12.7 (8.8)	12.2 (7.1)	12.9 (8.9)
Tenacity (cN/tex)	20.0 (19.4)	22.6 (20.3)	24.0 (21.6)
Breaking elongation (%)	10.1 (10.4)	10.0 (10.3)	9.6 (9.9)
Abrasion resistance (cycles)	3641 (2299)	4406 (2351)	4994 (2473)
Flexural rigidity (dynes-cm <sup>2</sup> )	35.8 (39.6)	37.8 (50.6)	42.7 (61.3)

<sup>a</sup>Figures in parentheses indicate values for trilobal polyester fibre.

Source: Tyagi and Khanna (2005).

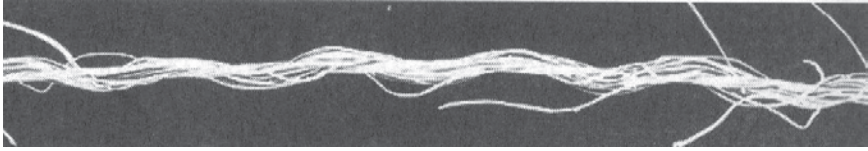

5.8 Wrap spun yarn surface structure.

### 5.6.2 Factors affecting wrap yarn characteristics

The properties of wrap spun yarns strongly depend on the properties of the wrapper filament, and the choice of the filament must always take into account the linear density and the end use requirements of the yarn (Taub, 1980). The uniformity of the wrapper filament affects the evenness of the composite yarn. Of equal importance is the need to ensure optimal radial pressure on the core by the wrapping filament. Yarn strength is greatly influenced by the filament modulus and the wrap density. A coarse filament is generally recommended for sewing threads and industrial yarns (Taub, 1980). A monofilament will wrap round the core fibres like a wire spring, whereas a multifilament gives a ribbon wrap structure (Steiner, 1983).

The distance between the front roller and the hollow spindle significantly influences the resulting yarn properties. Increasing this distance will adversely affect the orientation of the core fibres, and produce yarns with lower strengths and elongations. The tenacity and elongation of wrap spun yarn is determined not only by wrapping density, but also by the linear density and tensile properties of the wrapping filament yarn (Behery and Nunes, 1986). This is because the tensile properties of the filament yarn generate the bending tension and, together with the linear density of the filament yarn and the amount of wraps per unit length, produce the geometrical configuration of the fibrous core and the inter-fibre frictional forces within the core and between the surface of the core and the filament itself.

### 5.6.3 End uses of wrap spun yarns

Wrap spun yarns are suitable for weaving and knitting. These yarns find applications in carpets, knitted outerwear, blankets, towels and furnishings.

## 5.7 Structure–property relationships of staple spun yarns

### 5.7.1 Tenacity

The properties of staple spun yarns are strongly related to their structural characteristics. This can be best understood by comparing the distinctive

structural differences of the yarns produced by the four staple spinning systems of most commercial importance: ring, rotor, friction and air-jet spinning.

Ring yarns provide a unique combination of structural features that contribute to a consistently higher yarn tenacity that is not possible with any other yarn structure. This unique combination of structural features is made up of the greatest proportion of straight and parallel fibres, a high level of migration, and a reasonably high packing density. These structural features permit the greatest translation of fibre-to-yarn strength (i.e. fibre strength utilization).

Rotor and friction spun yarn strengths range from weaker to much weaker than that of ring spun yarn, depending on the fibre and processing parameters used. The yarn structural features responsible for lower yarn strength are as follows: in the case of rotor spun yarns, disoriented and folded fibres in the core, lower fibre packing, non-load-sharing wrapper fibres, and a low level of migration; and in the case of friction spun yarns, the presence of highly disoriented and folded sheath fibres as well as a low degree of fibre packing in the yarn core.

As described earlier, air-jet yarns have surface fibres tightly wrapped around a core of parallel and straight fibres which generate sufficient radial pressure on the core fibres to give a better translation of fibre-to-yarn strength than in rotor or friction spun yarns. Changes in yarn properties with various process parameters have therefore been explained by the changes in the structural parameters (Lawrence and Baqui, 1991).

### 5.7.2 Breaking elongation

Air-jet yarns are least extensible due to an untwisted core of straight and parallel fibres comprising 90% of the population. In comparison with ring spun yarns, rotor spun yarns have a higher breaking elongation, though it is lower than that of friction spun yarns. The large proportion of hooked and disordered fibres in the sheath and the low tension used during friction spinning tend to make the structure less dense and more extensible. The unique combination of yarn structural features responsible for the higher breaking elongation of rotor spun yarns is a higher incidence of hooked and disoriented fibres in the structure and a low level of spinning tension.

### 5.7.3 Abrasion resistance

Abrasion resistance is often considerably higher for rotor spun yarns than for ring spun yarns, presumably due to surface fibre configurations. However, comparing air-jet and ring spun yarns, the former is inferior in terms of abrasion resistance. The reason is that with air-jet yarns, the wrapper fibres do not adequately shield the yarn core, and consequently this leads to its

early exposure to abrasion. Ring spun yarns, on the other hand, are spun under the highest level of spinning tension, and there are no hooked fibres in the structure, but the helical arrangement of fibres is a highly significant factor in determining yarn breaking elongation during abrasion.

#### 5.7.4 Bending rigidity

It is generally recognized that air-jet spun yarns display higher bending rigidity (i.e. specific rigidity) than the equivalent yarns spun on other spinning systems. The clustering effect of core fibres due to the parallel arrangement and tightly wound binding fibres restricts the freedom of fibre movement during bending. Rotor spun and friction spun yarns are more rigid structures than ring spun yarns because of their compact core and large diameters. In the case of ring spun yarns, the helical fibre arrangement is a contributing factor to the lower bending rigidity.

### 5.8 The plying of staple fibre yarns

#### 5.8.1 Ring spun yarns

Generally, when staple fibre yarns do not meet the property requirements for certain applications it becomes necessary to ply two or more of the same yarn to form a plied yarn with improved characteristics. Most plied yarns throughout the world are produced from ring spun yarns because of their specific structure and their suitability to plying. Ply-twisting ring yarns in the direction opposite to the spin twist results in a fully balanced yarn that is more even and less hairy, has higher tenacity and breaking extension, has higher abrasion resistance and fewer imperfections than the component single yarns. Plied yarns are also produced by ply-twisting in the same direction, i.e. twist-over-twist. Such yarns generally have more compactness and retain some twist-liveliness. The level of ply-twist used is usually determined by the number of single components folded together, the yarn linear density and spin twist. The direction of ply-twist in yarns depends on their intended use.

#### 5.8.2 Rotor spun yarns

Rotor spun yarns are generally superior in breaking extension and short-term regularity and have fewer imperfections compared to ring spun yarns, but lack the quality characteristics of plied ring spun yarns. Consequently, there has been a considerable increase in the production of plied rotor yarns in the recent years. However, a simple substitution of plied rotor yarns for plied ring spun yarns has been possible only for selective applications. Plied rotor spun yarns have much higher tenacity and breaking elongation compared

with singles rotor yarn of the equivalent count as a result of plying (Kaushik *et al.*, 1987b). The improvement in tenacity is more marked for twist-over-twist yarns plied from low-twist singles yarn and consistently decreases with increase in singles' twist factor. The explanation for this is as follows. The improvement in tenacity results from the fact that binding single yarns together increases the binding of the fibres within each individual yarn and leads to a higher inter-fibre cohesion. However, because the number of wrapper fibres increases with increased singles' twist factor, they restrict the tightness of the binding by the ply twist. Hence the tenacities of plied rotor yarns prepared from highly twisted singles are lower than those from low-twisted singles.

### 5.8.3 Air-jet spun yarns

Ply-twisting has a beneficial effect on the tensile characteristics of air-jet spun yarns and it is only necessary to use 60–70% of the ply-twist which would be needed for ring spun yarns of equivalent counts. Tenacity increases and rigidity decreases for ply-twist when twisting is in the opposite direction to wrapping of the surface fibres (Chattopadhyay, 1997). Studies with viscose air-jet spun yarns (Tyagi and Dhamija, 2000) have shown that improvement in yarn properties depends upon the feed ratio, the second jet pressure, and the level and direction of ply-twist. Z-ply yarns were more rigid than S-ply yarns, but the flexural rigidity of Z-ply yarns consistently decreases as the ply-twist factor increases. S-ply yarns twisted with a higher twist factor were less rigid than single yarns of equivalent count and the rigidity of the plied yarns further decreased with decreasing feed ratio and second jet pressure.

### 5.8.4 Friction spun yarns

Although friction spun yarns are usually weaker than other yarns, their strengths can be improved through ply-twisting (Lord and Radhakrishniah, 1987). Chattopadhyay and Chakrabarti (1998) have also reported a substantial rise in friction spun yarn tenacity as a result of plying. Cotton yarns in particular derived maximum benefit in terms of gain in tenacity and breaking elongation. The level of ply-twist was found to have little effect on the yarn tenacity, whereas the direction of ply-twist was important; friction spun yarns should generally be plied in the same direction as their wrapping sheath fibres.

## 5.9 Future trends

The future trends in staple fibre spinning can be predicted by a careful scrutiny of current developments and extrapolation of various scientific innovations. The starting point is a basic assumption, quite familiar to every

spinner, that staple fibre yarns, irrespective of the spinning system, must meet ever-increasing demands in quality. Effectively, ring spun yarn has been dominant due to its unique yarn characteristics and unmatched versatility. However, for some time now rotor spun yarn has occupied the undisputed domain of coarse count yarns owing to the high productivity of the process and their superior evenness.

Over the past 27 years, air-jet spinning has become the most favoured method of spinning fine staple yarns on an economic basis. Development activities during recent years have concentrated on improving yarn quality through design modifications, and such work has led to the recognized need to optimize product specifications. However, some undesirable features and sectorial applicability of the yarns spun on these spinning systems have restricted their suitability for some commercially important applications, in particular for knitted fabrics where yarns are required with a low twist for a soft handle. A viable commercial friction machine to spin good quality fine yarns still remains a shimmering dream. There seems to be a pressing necessity to improve the quality of yarns spun on these non-traditional spinning systems and, in particular, to solve the problem of the harsh feel of air-jet yarn fabric through suitable design and process modifications. Such steps would no doubt make these new technologies more attractive.

## 5.10 Acknowledgements

I am indebted to Professor C. A. Lawrence, Director of Centre for Technical Textiles, School of Design, University of Leeds, UK for giving me an opportunity to provide a comprehensive discussion of staple yarns spun by unconventional spinning systems.

The author is grateful to various publishers who have kindly given permission for the reproduction of tables used in this section that have originally appeared elsewhere. Acknowledgement is therefore made to Wiley Interscience for Table 5.1, and to the National Institute of Science Communication and Information Resources for Figure 5.4 and Tables 5.2, 5.3, 5.4 and 5.6.

## 5.11 References

- Alagha M J, Oxenham W and Iype C (1994), Influence of production speed on the tenacity and structure of friction spun yarns, *Text Res J*, 64, 185–189.
- Artzt P, Muller H, Joas W and Wittmann M (1992), Influence of fibre length and fibre fineness of polyester and modal fibres on spinning stability and yarn properties with 32 mm rotor diameter, *Melliand Textilber*, 73(3), E78–E80.
- Barella A (1999), Hairiness testing of spun yarns, in Kothari V K, *Progress in Textiles; Science and Technology. Vol. 1: Testing and Quality Management*, New Delhi, IAFL, 232–303.

- Barella A and Vigo J P (1980), An application of mini-computers to the optimization of the open-end spinning process; Part X: The influence of twist and total draft on the properties of open-end spun polyester fibre yarns, *J Text Inst*, 71, 189–194.
- Barella A, Vigo J P and Manich A M (1980), The relationship between the twist and resistance to repeated extensions of man-made fibre rotor-spun yarns, *J Text Inst*, 71, 242–251.
- Barella A, Bardi X and Castrol L (1991), Yarn attrition and hairiness: The influence of loop sense on self-friction test results, *J Text Inst*, 82, 496–499.
- Basu A (1991), Influence of fibre type on properties of jet-spun yarns, Doctoral thesis, University of Leeds, UK.
- Behery H M and Nunes M F (1986), The structure, tensile properties, and morphology of failure of wrapped yarns, *J Text Inst*, 77, 386–402.
- Bhortakke M K, Nishimura T, Matsuo T, Ivone Y and Morihashi T (1997), High speed yarn production with air-jet spinning: Effects of some fibre parameters, *Text Res J*, 67, 101–108.
- Chasmawala R J, Hansen S M and Jayaraman S (1990), Structure and properties of air-jet spun yarns, *Text Res J*, 60, 61–69.
- Chattopadhyay R (1993), Structure and properties of spun yarns, in *Advances in Yarn Manufacturing Process*, New Delhi, Indian Institute of Technology, 162–176.
- Chattopadhyay R (1997), The influence of plying on tenacity, breaking extension, and flexural rigidity of air-jet spun yarns, *J Text Inst*, 88, 76–78.
- Chattopadhyay R and Banerjee S (1997), The frictional behaviour of ring-, rotor- and friction- spun yarns, *J Text Inst*, 88, 59–66.
- Chattopadhyay R and Chakrabarti A K (1998), Influence of plying on tensile behavior of friction spun yarns, in *39th Technological Conference*, New Delhi, Indian Institute of Technology, 76–83.
- Deussen H (1989), Conventional and novel short staple spinning systems, *Melliand Textilber*, 70, E352–E354.
- Ernst H (1993), Rotor yarns – a look into the future, *Melliand Textilber*, 74(4), E117–E120.
- Gowda M (2001), Influence of frictional characteristics of core and sheath on structure, twist and tensile properties of Dref-3 friction spun yarns, Doctoral thesis, New Delhi, Indian Institute of Technology.
- Hearle J W S, Grosberg P and Backer S (1969), *Structural Mechanics of Fibres, Yarns and Fabrics*, New York, Wiley Interscience.
- Hunter L (1978), The production and properties of staple fibre yarns made by recently developed techniques, *Text Prog*, 10(1/2), 65–68.
- Ishtiaque S M (1992), Spinning of synthetic fibres and blends on rotor spinning machines, *Indian J Fibre Text Res*, 17, 224–230.
- Ishtiaque S M and Khare S K (1993), Yarns in cross-section, *Text Asia*, 24, 36–38.
- Kampl R and Leitner J (1989), Use of viscose and modal fibres in unconventional spinning process, *Melliand Textilber*, 70, E134–E135.
- Kaushik R C D, Salhotra K R and Tyagi G K (1987a), Contribution of fibre length and fibre denier to characteristics of ring- and rotor-spun yarns, *Indian J Fibre Text Res*, 12, 146–148.
- Kaushik R C D, Salhotra K R and Tyagi G K (1987b), Influence of doubling on characteristics of acrylic-viscose rayon rotor spun yarns, *Indian J Fibre Text Res*, 12, 142–145.
- Kaushik R C D, Salhotra K R and Tyagi G K (1993), Viscose MJS yarn characteristics, *Text Asia*, 24, 56–58.

- Konda F, Okamura M and Merati A A (1996), Effect of suction pressure in friction spinning on yarn properties, *Text Res J*, 66, 446–452.
- Lawrence C A and Baqui M A (1991), Effects of machine variables on the structure and properties of air-jet fasciated yarns, *Text Res J*, 61, 123–130.
- Lawrence C A and Chen K Z (1984), Rotor spinning, *Text Prog*, 13(4), 54–58.
- Lawrence C A and Finikopulos E (1992), Factors effecting changes in the structure and properties of open-end rotor yarns, *Indian J Fibre Text Res*, 17, 201–208.
- Lord P R and Grady P L (1976), The twist structure of open-end yarns, *Text Res J*, 46, 123–130.
- Lord P R and Radhakrishniah P (1987), Tenacity of plied friction-spun, rotor-spun, and ring-spun yarns, *J Text Inst*, 78, 140–142.
- Louis G L, Salaun H L and Kimmel L B (1985), Comparison of properties of cotton yarns produced by Dref-3, ring- and open-end spinning methods, *Text Res J*, 55, 344–351.
- Lunenschloss J, Brockmanns K J and Phoa T T (1986), Cotton processing by new spinning technologies – possibilities and limits, *Int Text Bull*, 32, 7–22.
- Manich A M, de Castellar D and Barella A (1986), Influence of a yarn extractive nozzle on the apparent loss of twist in rotor open-end acrylic staple spun yarns, *Text Res J*, 56, 207–211.
- Martindale J G (1945), A new method of measuring the irregularity of yarns with some observations on the origin of irregularities in worsted slivers and yarns, *J Text Inst*, 36, T35–T47.
- Mohamed M H, Lord P R and Saleh H A (1975), A comparison of hairiness and diameter of ring and open-end yarns, *Text Res J*, 45, 389–395.
- Morton W E and Yen K C (1952), The arrangement of fibres in fibro yarns, *J Text Inst*, 43, T60–T66.
- Nield R (1975), *Open-end Spinning*, The Textile Institute, Manchester, UK, 22–27.
- Padmanabhan A R and Ramakrishnan N (1993), Influence of process parameters on the properties of friction spun yarns, *Indian J Fibre Text Res*, 18, 14–19.
- Punj S K, Ishtiaque S M and Dhingra L K (1997), Influence of spinning conditions on structure and properties of polyester-viscose blended MJS yarns, *Indian J Fibre Text Res*, 22, 73–83.
- Rajamanickam R, Patel M, Hansen S M and Jayaraman S (1998), Interaction of process and material parameters in air-jet spinning, *Text Res J*, 68, 708–714.
- Rust J P and Lord P R (1991), Variations in yarn properties caused by a series of design changes in a friction spinning machine, *Text Res J*, 61, 645–655.
- Saad M A and Sherouf A M (1989), Yarn tension variations in friction spinning, *Text Asia*, 20, 61–64.
- Salhotra K R (1992), An overview of spinning technologies: possibilities, applications and limitations, *Indian J Fibre Text Res*, 17, 255–262.
- Santjer H J (1991), Polyester for air-jet spinning, *Text Asia*, 22, 26–32.
- Sengupta A K, Chattopadhyay R, Venkatchelapathi G S and Padmanabhan A R (1992), Influence of spin finish and core-sheath ratio on the mechanical properties of friction-spun yarns, *Melliand Textilber*, 73, E83–E84.
- Simpson J and Murray M F (1978), Effect of cotton fibre fineness and strength on mechanical processing and open-end spinning and yarn properties, *Text Res J*, 48, 270–276.
- Stalder H (1990), Spinning in the 1990s, *Text Asia*, 21, 59–64.
- Stalder H (1991), High performance ring spinning, *Melliand Textilber*, 72, E245–E247.

- Stalder H and Soliman H A (1987), Yarn tension in friction spinning, *Text Asia*, 18, 101–105.
- Steiner E (1983), Wrap-spun yarns: the advantages, *Text Horizons*, 3, 27–30.
- Taub E H (1980), Coverspun: a new yarn formation process, *Can Text J*, 97, 49–60.
- Tyagi G K and Dhamija S (2000), Quality aspects of viscose jet-spun plied yarns, *Indian J Fibre Text Res*, 25, 284–288.
- Tyagi G K and Doshi N (2006), Polyester-viscose and polyester-cotton yarns compared, *Text Asia*, 37, 29–32.
- Tyagi G K and Khanna Y (2005), Structural and mechanical properties of polyester Dref-3 yarns produced with different core-wrapper ratios and production speeds, *Indian J Fibre Text Res*, 30, 407–413.
- Tyagi G K and Salhotra K R (1996a), Influence of process parameters on characteristics of MJS yarns, *Indian J Fibre Text Res*, 21, 184–188.
- Tyagi G K and Salhotra K R (1996b), Polyester-viscose fasciated yarns, *Indian Text J*, 106, 50–52.
- Tyagi G K, Salhotra K R and Gupta S (1995), Effect of core-wrapper ratio and spinning speed on physical properties of acrylic Dref-3 yarns, *Indian J Fibre Text Res*, 20, 136–138.
- Tyagi G K, Dhamija S and Salhotra K R (1999), Influence of fibre length and opening roller speed on physical properties of OE rotor-spun yarns, *Indian J Fibre Text Res*, 24, 21–26.
- Tyagi G K, Kaushik R C D and Salhotra K R (2000), Radial packing density and related properties of polyester Dref-3 yarns, *Indian J Fibre Text Res*, 25, 20–24.
- Tyagi G K, Jindal R and Salhotra K R (2001), Influence of spin finish and opening roller speed on the mechanical properties of polyester OE rotor yarns produced with different draw-off nozzles, *Indian J Fibre Text Res*, 26, 392–397.
- Tyagi G K, Saini A, Tyagi A and Khandelwal M (2002), Influence of fibre cross-sectional shape on dye uptake and mechanical characteristics of polyester OE rotor-spun yarns, *Indian J Fibre Text Res*, 27, 11–17.
- Tyagi G K, Singh A, Gupta A and Goyal A (2003), Effect of add-on finish and process variables on properties of air-jet spun polyester yarns, *Indian J Fibre Text Res*, 28, 163–169.
- Tyagi G K, Gopal A and Gon D P (2007), Contribution of fibre profile to performance characteristics of polyester-viscose and polyester-cotton ring- and MJS yarns, *Indian J Fibre Text Res*, 32, 404–408.
- Ulku S, Ozipek B and Acar M (1995), Effects of opening roller speed on the fibre and yarn properties in open-end friction spinning, *Text Res J*, 65, 34–39.
- Vigo J P and Barella A (1981), Influence of opening roller type on properties of open-end polyester-viscose yarns, *Text Res J*, 51, 34–39.
- Wang X (1987), Relationship between spinning condition and yarn quality of air-jet spinning machine type 801 MJS, *Text Res J*, 57, 227–234.
- Wang X, Huang W and Huang X B (1999), A study on the formation of yarn hairiness, *J Text Inst*, 90, 555–569.

## Yarn structural requirements for knitted and woven fabrics

---

H. M. BEHERY, Clemson University, USA

**Abstract:** Fundamentally, this chapter discusses the principal requirements for both knitted and woven fabrics with regard to their end uses. Knitted and woven fabric properties are presented in relation to both fiber and yarn properties. Fiber types, classification, performance and end uses are introduced. A classification of yarn types with regard to their fiber content, structure, twist and method of manufacture, as well as a survey of their physical and mechanical properties, is given. The criteria for the choice of fibers and yarns to suit fabric end uses and performance are outlined.

**Key words:** fibers, yarns, fabric properties, requirements for knitted and woven fabric properties, criteria for choice of fibers and yarns.

### 6.1 Introduction

This chapter describes yarn structure–property relationships for knitted and woven fabrics, particularly the principal requirements for the more common end uses for such fabrics. Importantly, the material presented begins with reference to fiber converted into yarns for knitted and woven end uses.

The applications for fibers commonly used for consumer clothing made mostly from woven and knitted materials have expanded to include felts, geotextiles, industrial fabrics, home furnishings, etc. The more technically advanced fibers, termed high performance fibers, find applications in performance fabrics such as flight spacesuits and firefighters' uniforms, as well as racing car drivers' suits. These fabrics protect the wearer from extremes of temperature. Other uses of these fibers are as reinforcement elements in flexible composite materials, such as automobile tires or belts, as well as rigid composite materials, such as boat hulls, tennis rackets, skis, aerospace applications and bicycle frames. In the field of medical textiles, applications are in surgical operation room gowns and many hospital general supplies. One of the newest areas of application is intelligent textiles and clothing. These are materials and products which react to external physiological stimuli such as temperature and change their shape or properties to provide the necessary protection or comfort.

## 6.2 Fiber types and their classification

Textile fibers can be grouped into two distinct classes:

1. Natural fibers
2. Man-made fibers.

Figure 6.1 shows the fiber classification chart. The natural fibers listed in the chart and certain of the various man-made fibers, e.g. regenerated cellulosic fibers, and the synthetics, such as acrylic, nylon and polyester, are the more widely used materials. The reader is advised to consult the textbooks presented at the end of the chapter for sources of information, in particular the book *Textile Fibers* by Matthews which provides an encyclopedia of fibers.

## 6.3 Principal requirements for knitted fabric end uses

Besides the great variety in the quality of knitted goods, and the fact that the performance of any individual knit may differ from those of other knits, some general guidelines should be observed as principal requirements for knitted fabric end uses.

In Section 6.3.1 some of the knitted fabric properties which give the knit good quality and functionality are outlined. However, the following are equally important as part of knitted fabric performance. These are the problems that consumers seem to encounter most often in the performance of knitted goods:

- Shrinkage
- Stretching
- Distortion of knits
- Skewing or twisting as the fabric is relaxed during laundering
- Snagging: the loop structure of knitted fabrics makes them especially susceptible to snagging.
- Pilling: double knits or knits made from loosely twisted synthetic yarns may be subject to pilling. Weaker fibers, such as cotton, rayon, acetate, and wool, generally break off the fabric.
- Damage by sharp objects: knits may be damaged by sharp objects puncturing the fabric.

### 6.3.1 Knitted fabric properties

Among the different physical and mechanical properties, the following are the ones that mostly reflect on the fabric performance:

- Dimensional stability: excellent elongation or stretch combined with good elastic recovery or return to shape.

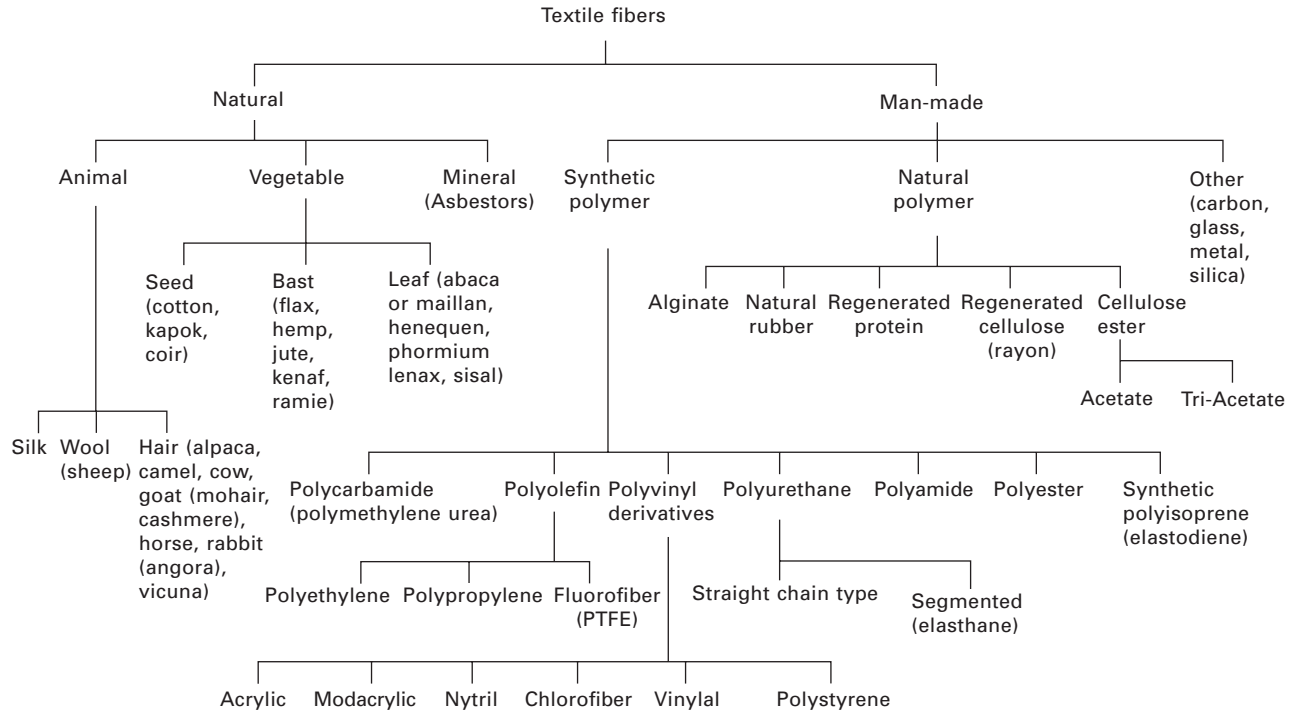

6.1 Classification of textile fibers (source: Synthetic Filament Yarn: Texturing Technology by Ali Demir and Hassan Behery, 1997. Reproduced with permission from Prentice-Hall, Inc.).

- Durability factor: Strength of knitted fabrics is considered to be less important for durability. Knitted fabrics are easily stretched to accommodate changes of shape as a result of stresses imposed in wear and care.
- Outstanding resistance to wrinkling and wrinkle recovery, because the yarns can move freely. Heavier knits resist wrinkling more than lighter weight single knits.
- Comfort factors: knitted goods are porous, providing moisture absorption and comfort, and allowing freedom of movement (e.g. jogging and sports wear).

### 6.3.2 Fiber properties affecting knitted goods

The most significant fiber properties affecting knitted goods may be grouped as follows.

#### *Raw material*

The fibers mostly used for knitting in 100% or blends are polyester, acrylic, cotton, wool, mohair, angora, lycra and some others.

#### *Physical properties*

Arbitrarily, the physical properties of textile fibers may be defined as those properties which characterize the fiber behavior other than mechanical properties. Such properties are as follows.

- Dimensional characteristics: length, diameter or nominal diameter (referred to sometimes as ‘fineness’), cross-sectional shape and area. Figure 6.2 illustrates typical cross-sectional shapes and fiber contours.
- Moisture sorption: also referred to as absorption, desorption and adsorption.
- Density: mostly as linear density in tex or denier.
- Friction, which is dependent on surface characteristics and crimp.
- Electrical properties, i.e. electrical resistivity (or conductivity) and the tendency to develop or carry electrostatic charges.
- Optical properties, i.e. degree of luster or light reflection.
- Thermal properties, which affect the degree of comfort and warmth.

#### *Mechanical properties*

The mechanical properties of fibers determine their ability to withstand stresses applied on them during manufacturing and end use. These may be categorized as:



Circular, uniform in diameter  
Nylon, Dacron

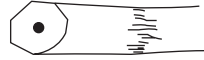

Polygonal lumen  
Flax



Oval to round, overlapping scales  
Wool



Flat oval, lumen convolutions  
Cotton

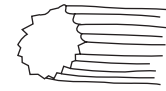

Circular, serrated, lengthwise striations  
Rayon



Lima bean, smooth

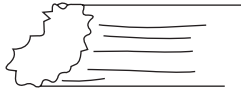

Lima bean, serrated  
Avril rayon



Triangular, rounded edges, uniform in man-mades

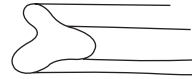

Trilobal  
Antron nylon

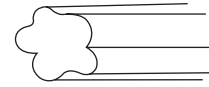

Lobular, lengthwise striations  
Acetate

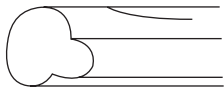

Mushroom (multiform)  
Orlon Sayelle



Dog-bone  
Orlon, Verel, Lycra

Silk, nylon type 90  
Dacron type 62

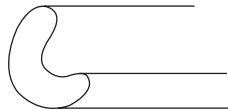

Ribbon-shaped  
Dynel

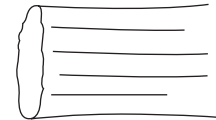

Flat, broad  
Crystal acetate



Y-shaped  
Celacloud,  
Type 20 acetate  
Cumuloft nylon

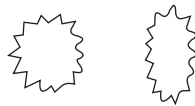

Star or concertina profile fibers



Collapsed tube, hollow center  
Avril rayon

### 6.2 Typical cross-section shapes and fiber contours.

- Tensile properties
- Elastic recovery
- Creep
- Relaxation.

For definitions, see the Appendix, Section 6.12. Figure 6.3 shows examples of a fiber load–elongation curve. The value of the stress at break is the tenacity of the fiber. There is a further determining mechanical property:

- Initial modulus.

Figure 6.4 shows the initial modulus or tensile modulus of the fiber, which is:

$$\text{Initial modulus} = \frac{\text{specific stress}}{\text{strain (\%)}} \tag{6.1}$$

of the initial portion (the straight line part) of the stress/strain curve. It is expressed in g/den or g/tex.

For most practical purposes, the performance of several of the fabrics lies within the area of low deformation. Therefore, the tensile modulus (initial modulus) explained above, as well as the bending modulus (or flexural modulus) and torsional modulus, are of interest in knitted goods and fabrics.

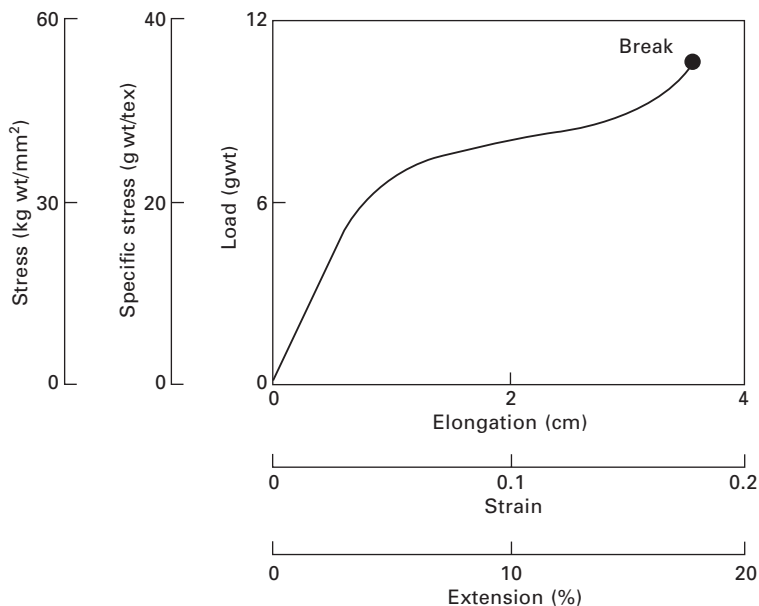

6.3 Load–elongation curve for 20 cm specimen of 0.3 tex filament with density of 1.5 g/cm<sup>3</sup> (specific stress at break = tenacity) (source: *Physical Properties of Textile Fibers*, by W.E. Morton and J.W.S. Hearle, 1975. Reproduced with permission from The Textile Institute, Manchester).

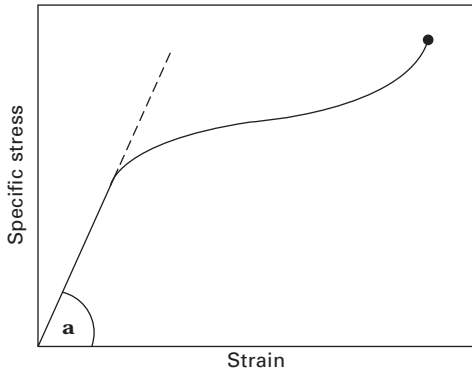

$$6.4 \text{ Initial modulus} = \tan a = \frac{\text{specific stress}}{\text{strain \%}} \quad (\text{source: } \textit{Physical}$$

*Properties of Textile Fibers*, by W.E. Morton and J.W.S. Hearle, 1975.  
Reproduced with permission from The Textile Institute, Manchester).

The tensile modulus is used to explain the reaction of the fiber to tensile loading. The bending modulus relates to the response of a fiber to the bending moment that usually occurs in knit loops. The torsional modulus is used to characterize the response of the fiber when twisted along its axis.

Figures 6.5 and 6.6 show actual stress/strain curves for different fibers. They illustrate the wide range of tensile properties of the different fibers and, hence, enable the fabric designer to choose the fiber which is more compatible with the end uses.

## 6.4 Principal requirements for woven fabric end uses

In woven fabrics, the weave used will have a significant influence on the durability, appearance and comfort of a product. There are three basic weaves: plain, twill and satin. Variations and modifications of these weaves allow for a wide variety of fabric constructions, and selection of different fibers and yarns adds to the possibilities.

Assessing the combined effect of fiber, yarn and weave on fabric performance is of major importance and this can be best illustrated by carefully considering the particular end use. This will be discussed later in Section 6.8: 'Criteria for choice of fibers and yarns to suit fabric end use and performance'.

### 6.4.1 Woven fabric properties

The following are the major woven fabric properties which provide woven goods with their unique performance.

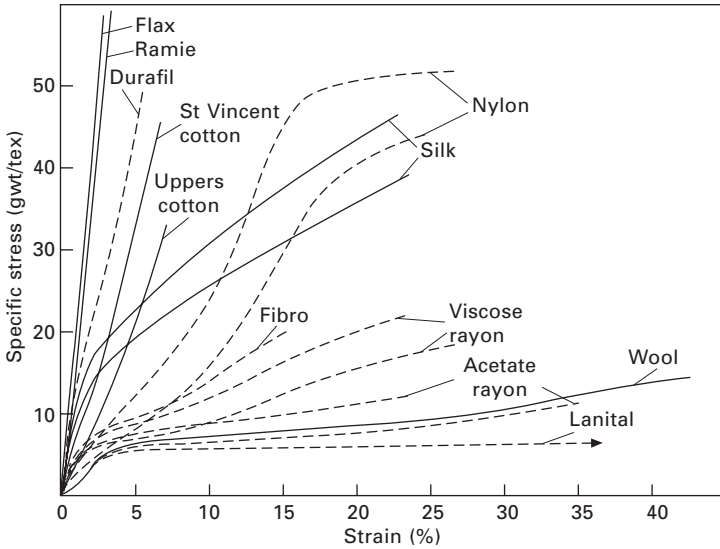

6.5 Stress-strain curves of various fibers tested at 65% r.h., 20 °C, 90  $\text{gf tex}^{-1} \text{min}^{-1}$  (source: Meredith, R., *J. Text. Inst.*, 1945, Vol. 36, T107).

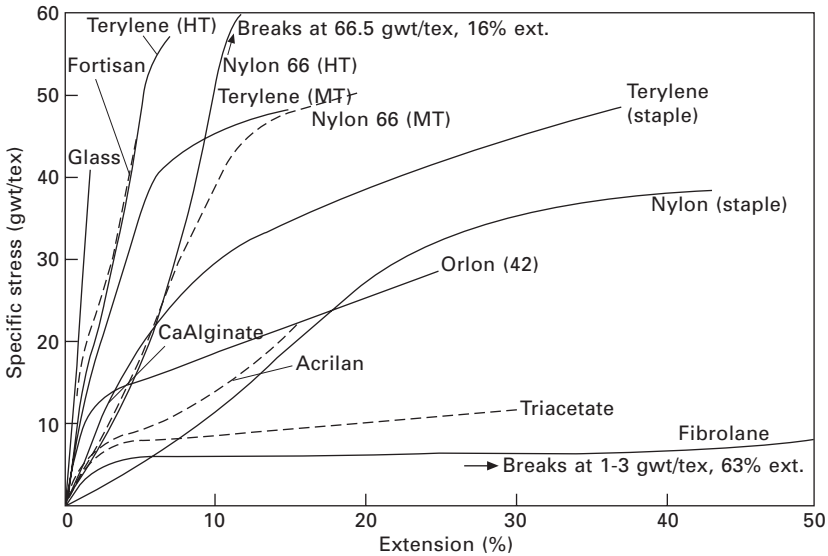

6.6 Stress-strain curves of various fibers (source: Farrow, B., *J. Text Inst.*, 1956, Vol. 47, T58).

*Dimensional stability*

Collier and Tortora (2001) explain that this property is often related to unreleased stresses introduced during fabric manufacturing. Fabrics and the

yarns in them must be kept under tension during weaving. As a result, they may be stretched beyond their normal (relaxed) dimensions. Later when the fabric is subjected to moisture or heat, the stresses within the fibers, yarns and fabrics are relaxed. This phenomenon is more pronounced in the case of thermoplastic fibers.

### *Drape and shearability*

Drape or the ability of fabric to form pleasing folds is related to bending and shearing behavior which are, in turn, affected by yarn and fabric properties.

Shearing is the deformation of a structure in which a rectangle becomes lozenge shaped. In woven fabrics, this results from movement of yarns from a normal position in which they run horizontally and vertically and interlace at right angles to other positions in which the interlacing is deformed away from 90°. Yarns and fabric structures that allow movement at the yarn intersection increase shearing. Woven fabrics with smooth yarns, low fabric counts, and higher crimp exhibit lower resistance to shearing.

Fabrics that shear easily are softer and more drapable, whereas fabric which is unable to shear will be stiff and does not mold or drape softly. In general, because of the ways in which yarns are combined, woven fabrics have higher shearability than other fabric structures.

Collier and Tortora (2001) point out that to form the graceful folds desirable in draping fabrics, they must also have low resistance to bending. Lower fabric counts and fine yarns with flexible fibers give fabrics the ability to bend easily and contribute to draping. Fabrics such as satins that have long floats in the weave are more flexible, bend more easily and improve draping qualities.

### *Durability*

Two of the most important fabric parameters affecting durability are the weave structure and the weight. According to Collier and Tortora (2001), the weave structure determines the interlacing in a fabric. Fabric weaves with more interlacing, such as plain weaves, can transfer and thereby share the tensile stresses at the intersection points. As a result, if fibers and yarns of comparable strength are used, they tend to have higher breaking strength than fabrics with fewer intersection points, such as satin weaves, and thus have greater durability.

### *Tearing strength*

This may be reduced in fabrics with many interlacings. In tightly woven plain weaves the yarns are bound in position and are unable to move to

group together to share the stress imposed in tearing. They therefore exhibit lower tearing strength than twills, oxford, or satins, all of which have fewer lacing points.

### *Tensile properties*

Collier and Tortora (2001) explain that the elongation and recovery of stress in woven fabrics are determined by the yarn mechanical properties and the fabric structure. The crimp added to yarns, as in textured yarns, and the crimp created in weaving when yarns are interlaced, termed fabric crimp, contribute to the fabric elongation. When warp and filling yarns cross each other, they cannot continue to move in an absolutely straight line, but each set of yarns must bend over and under yarns in the other set. As the fabric is stretched, the crimp in the direction of the stretch is removed, permitting the fabric structure to reach its maximum extensibility. The greater the yarn crimp, the more extensible the fabric.

### *Abrasion resistance*

Collier and Tortora (2001) indicated that in woven fabric construction, the level of fabric crimp plays an important role in the resistance to abrasion. The crown of the crimp, i.e. the part of the yarn that protrudes above the surface of the fabric, endures the main abrasive action. The more crowns of the same height there are in a given area of cloth, the more evenly the wear will be distributed over the surface of the fabric. Weaves also enter into abrasion resistance. In fabrics with floats, yarns and fibers are freer to move to absorb energy and are less consistently exposed to abrasants. This is why twills and some tightly woven satin fabrics show superior abrasion resistance.

## 6.4.2 Fiber properties affecting woven goods

The following fiber properties are additional to those properties mentioned before for knitted goods (Section 6.3.2), as woven goods cover a wide variety of goods and an immense spectrum of end uses.

### *Raw material*

In parallel with the technological and engineering advances and developments in processing and manufacturing machinery and equipment as surveyed elsewhere in this book, scientific efforts and activities have entered a new era with the introduction of a tremendous variety of new types of fibers in the textile field. Most of these new fibers are versatile enough to be used in the

various different methods of fabric formation, such as knitting and weaving and for nonwoven goods. However, there are always fibers that are more suitable for one type of fabric than another. For example, the fiber properties affecting knitted goods have been discussed earlier in this chapter.

As well as the fibers mostly used for knitting that were mentioned in Section 6.3.2, there are other high performance and specialty fibers that are more suitable for the production of woven fabrics. Examples are glass fibers, carbon fibers, ceramic, Kevlar, Nomax, and many others.

Due to the variety of end uses for woven fabrics and the continuous attempts to open new fields and applications of woven fabrics, sometimes attempting to replace knitted fabrics, the scope of fiber properties affecting woven goods has given woven fabric designers, producers and consumers almost unlimited choice to work with.

Since 1990, there have been considerable changes in the nature of the fibers being produced, in production methods, and in consumer values and expectations. The quantity of fibers being produced in Asian countries over this period has increased enormously. The advancement of high-tech fibers has continued, with ever finer subdivisions to meet specialized applications, as in high performance, high function and 'smart' fibers. Such fibers are being increasingly used for a wide range of applications including geotextiles and geomembranes and for construction and civil engineering projects. Another example is in the field of intelligent textiles and clothing, defined as products that react to exterior or physiological stimuli. These are divided into four categories: phase change materials, shape memory textiles, chromic materials and conductive materials.

### *Physical properties*

Similar to fabrics used in knitted goods and especially those woven fabrics used for similar end uses, the physical properties discussed before (Section 6.3.2) are almost equally important for both types of fabrics. Since woven fabrics are presently employed for a tremendous variety of end uses, some other physical properties are required to enhance their performance in these new fields. Examples of these applications are:

- Industrial applications, such as in building and construction materials, geotextiles, protective clothing and geomembranes.
- Specialty fabrics made from microfiber and high modulus and high tenacity materials (HM-HT).
- Medical textiles and smart textiles are now two of the most exciting areas in textiles and have found widespread application and end uses in healthcare, wound care and drug release systems.
- Smart fabrics and clothing, including smart technology for textiles and clothing, which also includes wearable electronics and communication

apparel that involves the interaction of smart textile clothing design with electronic devices.

Some of the physical properties mentioned before (Section 6.3.2) for knitted goods may have different effects in woven fabrics and goods from knitted goods. Some examples are as follows.

#### Dimensional properties

Fiber fineness affects the fabric 'hand', feel, appearance and aesthetic properties in general. It also affects the dimensional stability, fabric drape, luster and comfort.

#### Moisture absorption

Due to the compact structure of woven fabrics and goods in comparison to the openness of the knitted structure, moisture absorption in terms of regain percent may be lower for woven than for knitted fabrics. Since moisture absorption property affects several other physical properties of the fabrics, this will result in differences in physical properties of the two types of fabrics.

#### Density

Fiber density directly affects fabric weight and density, and in turn several other physical properties of the fabric, such as thermal properties, surface characteristics, friction and, ultimately, the fabric's 'hand'. It also affects the fabric's air permeability.

#### Friction

The surface characteristics of woven fabric are dependent on the constituent fiber friction properties, particularly as the fibers are assembled in the different yarn structures. This affects the abrasion property of the fabric.

#### *Mechanical properties*

The fiber mechanical properties discussed in Section 6.3.2 have a diverse effect on the performance of woven fabrics in their end uses due to the different modes of loading and stressing and, hence, the mechanism of failure of the woven fabrics. The fiber mechanical properties, together with the way the fibers are assembled into one of the different types of yarns (Section 6.5 below), will contribute to the woven fabric mechanical properties (Section 6.4.1).

## 6.5 Yarn types and their classification

Several classifications have been introduced in the literature. However, most address only one or two aspects of the classification. The author has, therefore, introduced a classification of yarn types according to four categories which encompass almost all yarns available in the industry. The four categories are:

1. Fiber type and content
2. Yarn structure
3. Yarn twist level
4. Method of manufacturing.

### 6.5.1 Classification of yarns according to fiber type and content

Figure 6.7 shows the classification of yarn according to fiber type and content. In the textile industry, yarns are made of one or two types of fibers. These are:

- Staple fiber yarns, spun from short or long staple fibers. In this case, the yarns are spun from 100% homogeneous fibers or blends of two or more types of fibers. Blended yarns provide certain characteristics and properties which cannot be obtained when using only one type of fiber.

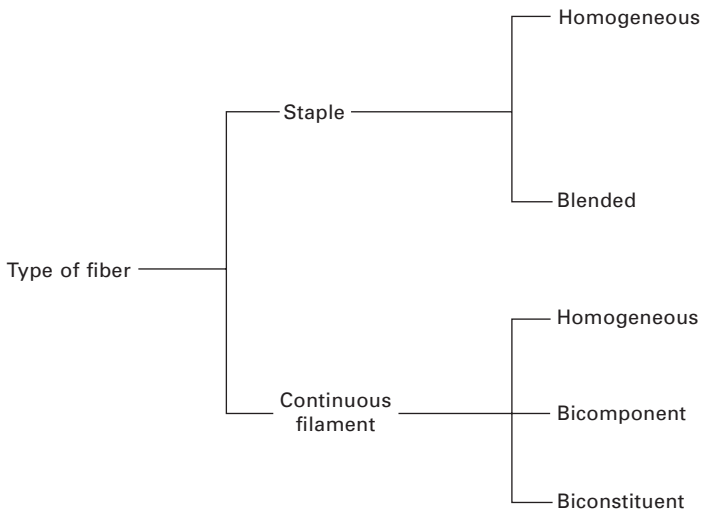

6.7 Classification of yarns according to fiber type and content.

- Continuous filament yarns, which are mostly produced from man-made fibers. These yarns could also be of 100% homogeneous, bicomponent or biconstituent filaments. Bicomponent continuous filament yarns are made by simultaneously extruding two molten filaments of different polymers which combine to form one continuous filament yarn. Figure 6.8 illustrates the formation of bicomponent filaments. Biconstituent continuous filament yarns are made by having one polymer dispersed within another polymer before they are extruded into a yarn, as also shown in Fig. 6.8.
- Combinations of staple fiber and continuous filament. Presently, there are yarns which are made by combining either staple fiber wrapped by continuous filament or staple fiber wrapped around a continuous filament in the core of the yarn. Core-spun yarn may be made with an elastomer core, such as Spandex, covered by another fiber to produce a stretch yarn. Core-spun yarns are used extensively in medical braces for knees, elbows and ankles. The staple fiber on the surface provides sheerness and comfort, especially when used in swimwear, active wear, underwear and hosiery.

### 6.5.2 Classification of yarns according to structure

Aside from the type of fibers converted into singles yarns, they can be classified according to their structural form as shown in Fig. 6.9 which also depicts their general appearances. The structural forms shown are:

- Single yarns
- Ply or multifold yarns
- Cabled or cord yarns
- Complex or core-spun yarns
- Fancy yarns, sometimes known as novelty yarns
- Modified continuous filament yarns.

These are described in turn below.

#### *Single yarns*

Single yarns occur in one of the following forms:

- A number of staple fibers (short to long in length) are twisted together to form a spun yarn.
- A number of filaments laid together with a small amount of twist (producer twist).
- Single filament with or without twist (monofilament).

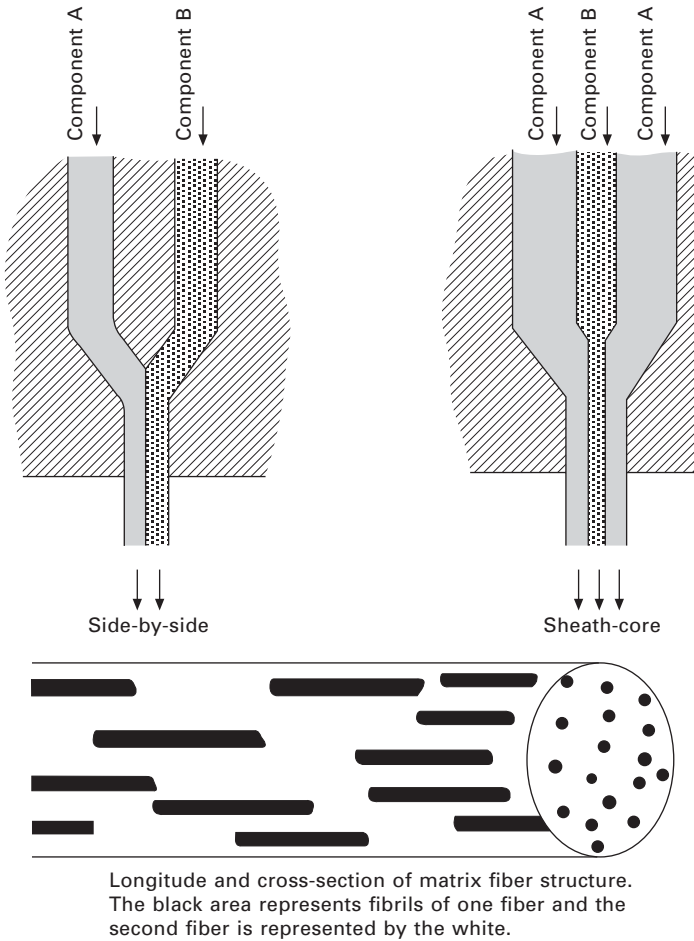

6.8 Formation of bicomponent and biconstituent fibers (source: *Understanding Textiles*, sixth edition, by B. J. Collier and P. G. Tortora, 2001. Reproduced with permission from Prentice-Hall, Inc.).

The structure of single yarns will be discussed in Section 6.6 which explains the fiber/yarn interaction that influences the yarn structure.

*Ply or multifold yarns*

These yarns are produced by twisting together two or more single yarns. This type of yarn has different properties from a single yarn of the same count. It has higher strength, higher uniformity and better abrasion and gives better fabric appearance. Fabrics made of this yarn in the warp do not



S Twist

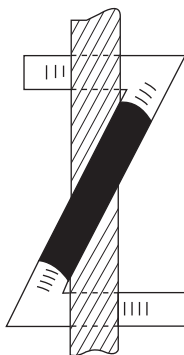

Z Twist



Both single yarns have Z-twist

2-fold yarn has S-twist



One single yarn has S-twist and the other Z-twist

2-fold yarn has Z-twist



All single yarns have Z-twist

Both 3-fold yarns have S-twist

Cord has Z-twist

6.9 Direction of twist and construction of plied and cord (cabled) yarn (source: *Methods of Test for Textiles*, British Standards Institution, Handbook No. 11, 1963, British Standards House, London).

need a sizing (or slashing) process before weaving. This type of yarn has a balanced twist, achieved by ply twisting the two singles yarns in the direction opposite to their twist, and therefore does not tend to snarl or untwist during

the knitting or weaving process, neither will it need steaming or conditioning prior to these processes. This is achieved by usually having the singles twist in the Z- direction and that of the ply in the S-direction. This yarn is more expensive than singles of the same count.

#### *Cabled or cord yarns*

This yarn is obtained by twisting together a multiple (i.e. multifold) of yarns. This type of yarn is mostly used in the tire industry and is designated as tire cord. It is manufactured to exhibit specific properties. Another example of the end use of this type of yarn is as a sewing thread. The performance of this yarn in the examples cited could not be obtained by any other yarn type, since the major properties provided are its strength, tensile modulus and elongation.

#### *Complex or core-spun yarns*

These yarns are made with a central core of one fiber around which is wrapped or twisted an exterior layer of another fiber. Core-spun yarns may be made with elastomer core, such as Spandex, covered by another fiber to produce a stretch yarn. Other core-spun yarns include sewing thread made with a polyester core and cotton cover, suitable for high speed industrial sewing processes in which 100% polyester thread could melt due to the high temperature that the sewing needle may reach.

#### *Fancy or novelty yarns*

These yarns are mainly of decorative interest. They are made by introducing special forms of irregularities or hairiness into either spun or continuous filament yarns. Many different yarns of this type are available in the industry, such as bouclé yarns, flake or seed yarns, nub yarns, slub yarns, spiral or corkscrew, and chenille yarns. Figure 6.10 shows some typical novelty yarns.

#### *Modified continuous filament yarns*

Continuous filament yarns are made from straight filaments which are smooth and slippery to the touch. They lack the bulk, comfort and tactile hand of yarns spun from staple fibers. Producers of continuous filament yarns tried to simulate the effects obtained by staple fiber yarns. First, they modified the luster of the filament from bright to semi-bright to dull. Second, they modified the structure of the filament by adding bulk and stretch, by various

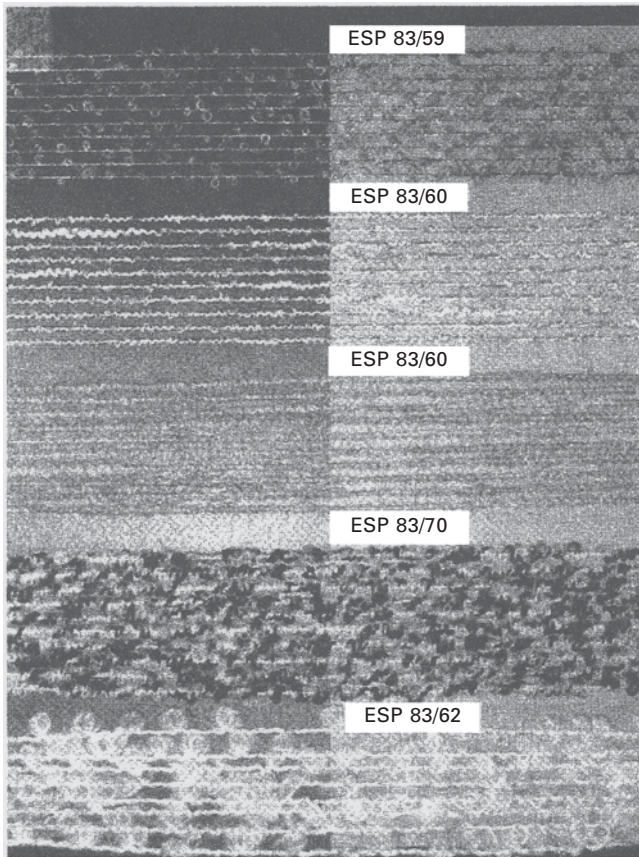

6.10 Some types of novelty yarns (source: *Effect of Mechanical and Physical Properties of Fabric Hand*, by H. M. Behery (editor), 2005. Woodhead Publishing, Cambridge, UK).

texturing processes. These processes are primarily to increase bulk for comfort, resilience and hand or to provide stretch to the yarn. The subject of texturing and the different technologies used with the resultant yarn structures obtained are discussed by Demir and Behery (1997).

### 6.5.3 Classification of yarns according to twist

Some filament yarns have twist applied to them to hold the filaments together and give them coherence. In filament yarns without twist, the individual filaments will spread out and separate from one another and the yarn will lack coherent unity and may cause processing problems as some of the filament could snag and break. In general, a small amount of twist (for example, half

a turn per inch – approximately 1/4 turn per centimeter) is inserted on the filaments, and is known as ‘producer twist’.

In staple fiber yarns, twist is important since it creates the frictional forces, which alone hold the individual fibers in the yarns. This occurs solely due to the transverse pressure which develops when a fiber wrapped in a helical path round other fibers in the yarn is put under tension.

Strength in staple fiber yarns increases as twist increases up to a certain point. Beyond this point, the strength of the yarn begins to decrease. As illustrated in Fig. 6.11, the strength in twisted staple yarns depends on two functions. One increases with the amount of twist and the other decreases with the helix angle due to the obliquity of the fibers with respect to the yarn axis, in other words, due to the component effect. The resultant strength shows a maximum.

As other properties of the yarn are affected by twist, such as bulkiness, absorbency, abrasion resistance, fabric appearance and surface property and hand, this has resulted in the classification of yarn according to the amount of twist, as each type of twisted yarn has found a particular end use according to its specific performance. This is shown in Fig. 6.12. These classifications are:

- Knitting yarn
- Filling yarn (weft yarn)
- Warp yarn
- Hosiery yarn
- Crepe yarn
- Voile yarn.

This classification is due mainly to the yarn strength and its bulk. Knitting

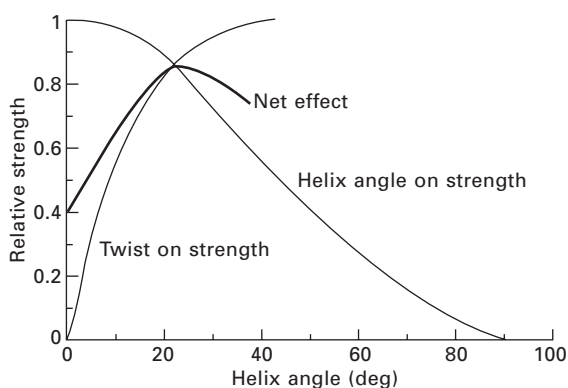

6.11 Effect of twist on modulus and strength of yarns (source: *Fiber Science*, by S. B. Warner, 1995. Reproduced with permission from Prentice-Hall, Inc.).

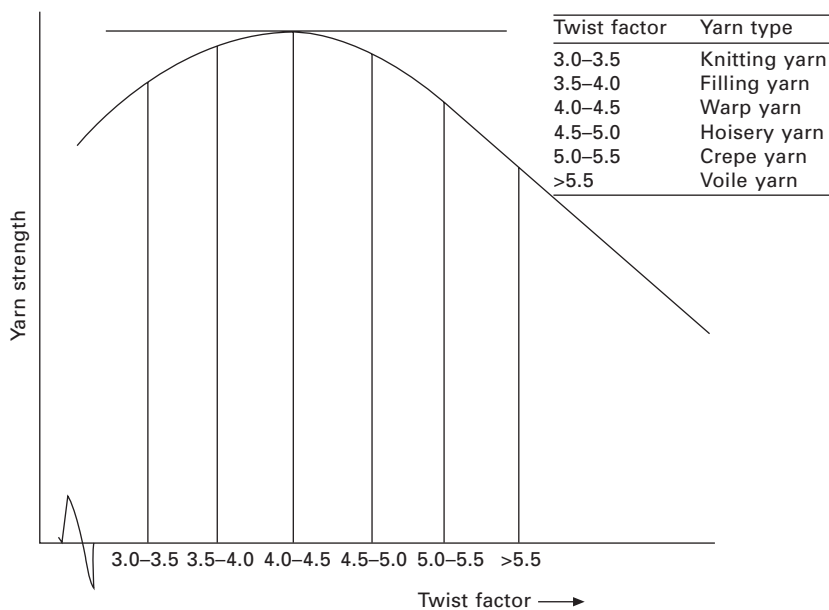

6.12 Classification of yarn according to level of twist.

yarns need more bulk to be absorbent and give high thermal comfort. The lower strength is agreeable with the less tension and stress encountered during the knitting process. The same could be said about the filling yarn (i.e. weft) in weaving. This usually has more bulk than the warp yarn, and provides the body (i.e. bulk) to the woven fabric. The filling yarn is also exposed to less tension and stress than the warp yarn. The warp yarn is the most tensioned and stressed during the weaving process and this is why it should have the maximum yarn strength.

The other three types of yarns, hosiery, crepe and voile, are produced by relatively higher twist, thus sacrificing strength and bulkiness, but acquiring other desirable properties such as surface texture and abrasion. Crepe yarns are known to be a tightly twisted yarn and they are generally very fine. The twist in crepe yarns is so high that they curl up unless they are held under tension, as they would be on a loom during weaving. This tendency of crepe yarn to curl makes fabrics constructed from these yarns less dimensionally stable than other fabric, as they are more elastic, and they have an uneven fabric surface.

In general, more tightly twisted yarns shed soil more easily, because there are fewer loose fiber ends to attract and hold soil. In yarns made from absorbent fibers, absorbency is lower in more tightly twisted yarns.

Crepe fabrics produced by using crepe yarns achieve a nubby, somewhat crinkled effect as the yarns have a less even surface texture. The fabric

designer can take advantage of these effects to create a wide variety of surface textures and designs.

### 6.5.4 Classification of yarns according to method of manufacturing

Figure 6.13 shows the different methods of yarn manufacture currently used in the textile industry. An overview of the developments in spinning technology, and the fundamental principles of ring spinning, open-end spinning and core yarn spinning, are presented and discussed in Chapters 1, 2 and 3 (Part I). The advances in spinning technology are presented and discussed, covering ring spinning, Siro spinning, compact spinning, rotor spinning, friction spinning, air-jet spinning, hollow spindle spinning and self-twist spinning, in Chapters 7–14 respectively (Part II). For information on any of these systems, the reader should refer to these chapters.

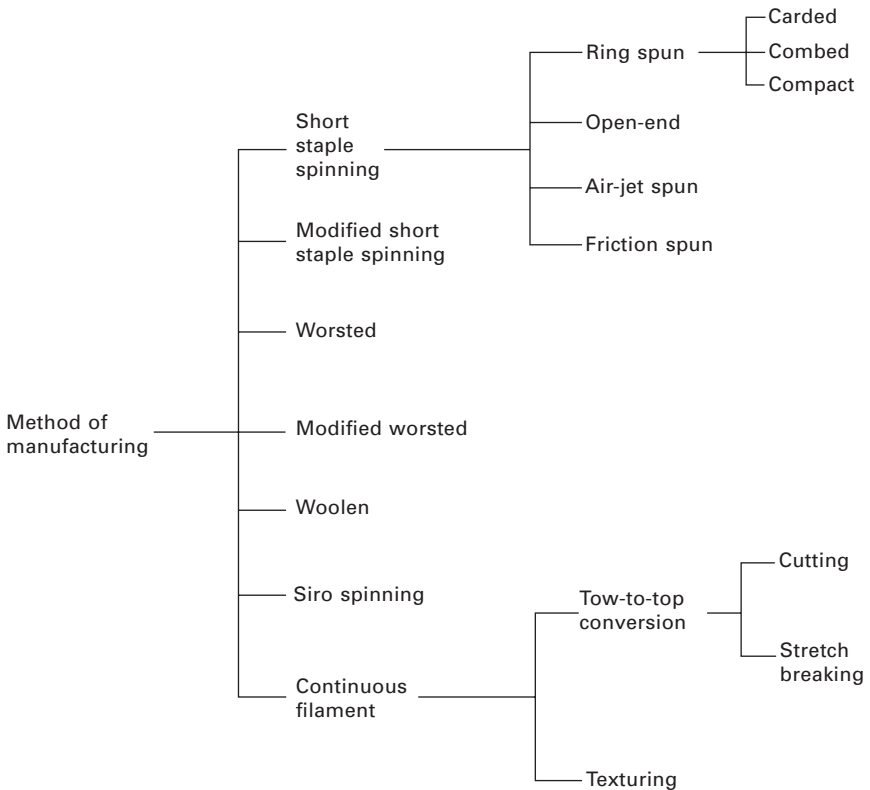

6.13 Classification of yarn according to methods of manufacturing.

## 6.6 Fiber/yarn/manufacturing process interactions and their effect on yarn structure

### 6.6.1 Fiber migration phenomenon

The phenomenon of fiber migration during processing of fibers, filaments and blends has been studied by many over a period of half a century. A very thorough treatment of fiber migration in staple and filament yarns and yarn structure in general is found in the book *Structural Mechanics of Fibers, Yarns and Fabrics*, by Hearle, Grosberg and Backer (1969).

Although a great deal of work on yarn structure has been reported in the literature, much work remains in relating the various factors which influence yarn structure and their relation to performance characteristics other than mechanical properties. The following is an overview of this phenomenon and the mechanisms by which it occurs.

### 6.6.2 Mechanisms of fiber migration

There are three major mechanisms which control migration behavior:

- Tension variation as a mechanism of migration (Morton and Yen, 1952)
- Geometric mechanism which depends on wrapped or ribbon twisting (Riding, 1964)
- Migration under the combination of the two mechanisms (Hearle, *et al.*, 1965).

### 6.6.3 Factors affecting migration

The various factors affecting fiber migration were outlined and discussed by Behery (1968). These factors could be most conveniently considered in three groups, namely fiber factors, yarn factors and the manufacturing process, and the interaction between these factors decides the final yarn structure. These factors are outlined as follows.

#### 1. Fiber factors

- Physical properties
  - length
  - fineness
  - shape or cross-section
  - coefficient of fiber friction
  - type of fiber or its chemical identity
- Mechanical properties
  - tensile modulus

- extensibility
  - elastic recovery
  - bending modulus or flexural rigidity
  - torsional rigidity.
2. Yarn factors
- yarn count
  - amount of twist in the roving (or producer twist in the continuous filament yarn)
  - amount of twist to be put in the yarn.
3. Processing factors
- tension during spinning
  - drafting system
  - amount of draft and draft distribution within the system
  - position of fibers as delivered by the machine front roll, particularly in the case of blending on drawing or roving frames
  - machine geometry and machine setting.

The final yarn structure will be affected and determined by any one of the above outlined factors. However, in most cases, multiple factors interact to enhance the positioning of the fibers between the yarn center and surface. Sometimes, multiple factors interact in a more complex fashion and the yarn structure will be decided by the effect of the factor that dominates the fiber movement during spinning.

It is essential for the fabric designer, when choosing the type of yarn which will be more appropriate for a particular end use and provides the best performance of the fabric, to take into account the results of the interaction of the fiber properties, yarn factors and the effect of the manufacturing process on the yarn structure. This information is available in the extensive work and studies reported in the literature over a long period of time. Information on the fundamentals, theories, and practice is given in references 1, 2, 6, 7, 10, 11 and 12.

## **6.7 Survey of yarn properties**

Tables 6.1 and 6.2 list the physical and mechanical properties to be considered when specifying a yarn for a knitted or woven fabric in accordance with the ultimately required fabric performance.

### **6.7.1 Physical properties**

Table 6.1 lists the physical properties of the yarns and the standard test method for each property, according to the American Standard for Testing and Materials (ASTM).

Table 6.1 Yarn physical properties and standard test methods

Type of yarn	Physical property	ASTM Standard Testing Method
Staple fiber yarn	• Fiber type: identification of fibers	D-27b-00a
	• Blend ratio: methods for quantitative analysis	D-629-99
Filament yarn	• Standard tolerance test method	D2497-(07.01)
	• Degree of filament entanglement	D4724-99
<i>For yarn structure</i>		
Single yarn	• Yarn number	
	– Yarn number or yarn count, by short length	D1059-97
	– Yarn number by skein method	D1907-97
	– Yarn number by automatic tester	D6587-2000
	– Yarn number and variability by automated tester	D6612-2001
	• Yarn evenness – using capacity testing equipment	D1425-96
	• Yarn appearance grade	
	– Grading spun yarn for appearance	D2255-02
	– Yarn classifying and counting faults in electronic tester	D6197-99
	Yarn structure single yarn	• Yarn evenness – using capacity testing equipment
• Yarn appearance grade		D2255-02
– Grading spin yarn for appearance		D2255-02
– Yarn classifying and counting faults in electronic tests		D6197-99
• Yarn hairiness - by photo-electric apparatus		D5647-01
• Yarn abrasion for wet and dry yarn-to-yarn abrasion resistance		D6611-00
• Yarn friction, for coefficient		D3108-01
– Of friction, yarn to solid material		
– For coefficient of friction yarn-to-yarn		D3412-01
• Amount and direction of twist		
– Twist in single yarns by the untwist–twist method	D1422-99	
– Twist in yarns by direct counting	D1423-02	
• Types of yarn structure designation of yarn constructing	D1244-98	
• Shrinkage property of yarn	D2259-02	
Textured yarns	• Bulk: method for bulk properties of textured yarns	D4031-01
	• Recoverable stretch: evaluation of recoverable stretch of stretch yarn (skein method)	D6720-01
	• Crimp and shrinkage properties: for textured yarns using a dynamic textured tester	D6774-02
Cotton yarns and/or fibers	• Moisture absorption property of yarn: for moisture in cotton by oven drying	D2495-01

Table 6.2 Yarn mechanical properties and standard test methods

Type of yarn	Mechanical property	ASTM Standard Testing Method
Single yarn	<ul style="list-style-type: none"> <li>• Tensile properties</li> <li>Tensile properties of yarns by the single strand method</li> <li>From this test, the following properties are obtained:               <ul style="list-style-type: none"> <li>a Tenacity (breaking strength) – g/tex or g/d</li> <li>b Breaking elongation (%)</li> <li>c Tensile modulus (or initial modulus) – g/tex or g/d</li> <li>d Cord modulus (between specific elongation) g/tex or g/d</li> <li>e Breaking toughness (work of rupture)</li> </ul> </li> </ul>	D2256-02
	<ul style="list-style-type: none"> <li>• Skein strength</li> <li>This is the test method for breaking strength of yarn in skein form.</li> </ul>	D1578-93 (reapproved 2000)

### 6.7.2 Mechanical properties

The mechanical properties of all types of yarns are similar to the mechanical properties of fibers and are expressed in the same units. These properties are listed in Table 6.2.

## 6.8 Criteria for choice of fibers and yarns to suit fabric end use and performance

The information presented in this chapter discussing the relationships between the properties of fibers, yarns and fabrics is needed to determine the criteria for the choices of the fundamental elements, the fibers, yarns and fabrics, to suit the end use and performance desired. The fiber types and their classification have been summarized and the physical and mechanical properties of the fibers which affect both knitted and woven goods have been outlined and discussed. In the meantime, some of the newly developed fibers and their specialty end uses have been mentioned. Understanding the effect of the fiber factor will undoubtedly provide the fundamental criteria for the proper choices to build upon for a fabric which will be appropriate to the required end use and performance.

A comprehensive classification of yarn types in accordance with fiber types and content, yarn structure, twist and method of manufacture is given together with a survey of their physical and mechanical properties. This will provide the other element of the criteria for the choice of yarn to suit fabric end use and performance.

The interaction of fiber, yarn and manufacturing process and their effect on the yarn structure have been explained in order to understand the yarn structure with respect to the position of the fibers in the yarn from its center to its surface. The phenomenon of fiber migration determines some important characteristics of the fabrics. For example, in polyester/cotton blend, being the most popular blend, the yarn structure obtained will depend largely on the physical properties of the fibers, such as fineness, denier and fiber length, and on the mechanical properties such as the tensile modulus, extensibility and elastic recovery. The yarn structure will vary depending on the positioning of the two fibers. When the polyester migrates mostly to the yarn center, cotton will occupy the majority of the yarn surface, the yarn will react to further processes as cotton yarn and will give the fabric the cotton fiber feel. In the meantime, polyester being in the center will provide more strength to the yarn. Ultimately, fabrics made of this yarn will have less abrasion, and other fabric properties will also be decided, such as drapeability, shearing, appearance, moisture absorption, etc. On the other hand, if polyester and cotton exchange their position in the yarn structure, with the cotton migrating to the yarn center and polyester staying mostly on the yarn surface, entirely different properties from those mentioned above will result, with the yarn having a different feel and more luster. The yarn will also have less strength and more abrasion resistance and will be more prone to pilling, with less moisture absorption capability.

Accordingly, it is the responsibility of garment designers to have a good understanding of the physical and mechanical properties of the material they will be working with. They must also consider the processing and other factors affecting the material during the manufacture of garments, and their end use.

## 6.9 Conclusions

From the topics presented in this chapter and throughout other chapters, the following conclusions could be outlined:

1. The scientific, engineering and technological advances that have been applied in the different phases of the textile industry, have highlighted the way to a greater understanding of the different interactions between fiber and machine, fiber and yarn, and yarn and fabric.
2. There is an endless variety of yarns that can be created by using different fibers, by twisting fibers more or less tightly, and by combining two or more individual yarns to form a more innovative product.
3. The potential for variation in fabric structure is enormous, resulting in an endless variety of textile structures that are produced to suit the different end uses and provide the utmost performance.

4. Those involved in testing and quality control, assessment and evaluation are provided with standard test methods which provide them with the information they need and/or the specifications for the products' end use and performance.

## 6.10 Sources of further information and advice

The following reference books cover the various aspects of the topics discussed in this chapter and some of the other chapters. These topics encompass properties of fibers, yarns and fabrics and their interactions. Readers and/or those involved in the various phases of the textile industry, namely fabric and apparel designers, researchers and those who are interested in product development, retailers and personnel responsible for quality control or quality assessment, will find a wealth of information and knowledge which will help them to improve their experience and widen their horizon and help them improve their products.

It is necessary to indicate that the references cited are a few of many that are available, and it is the author's sincere advice that continuous follow-up of the updated developments and information should be made.

*Annual Book of ASTM Standards* (2007), Section seven, textiles, Volume 07.1, 07.2. ASTM International, West Conshohocken, PA (email: service@astm.org)

Collier BJ and Tortora PG (2001), *Understanding Textiles*, sixth edition, Upper Saddle River, NJ, Prentice-Hall

Demir A and Behery HM (1997), *Synthetic Filament Yarn: Texturing Technology*, Upper Saddle River, NJ, Prentice-Hall

Hearle JWS, Grosberg P and Backer S (1969), *Structural Mechanics of Fibers, Yarns and Fabrics*, New York, Wiley-Interscience

Hongu T and Phillips GO (1997), *New Fibers*, second edition, Cambridge, UK, Woodhead Publishing

Matthews JM (1954), *Textile Fibers*, sixth edition, New York, John Wiley & Sons

Morton WE and Hearle JWS (1993), *Physical Properties of Textile Fibers*, third edition, Manchester, UK, The Textile Institute

Vaughn E (1992), *Principles of Woven, Knitted and Nonwoven Fabric Formation*, Clemson University, Clemson, SC

Warner SB (1995), *Fiber Science*, Dartmouth, MA, Prentice-Hall

## 6.11 References and bibliography

Behery HM (1968), Study of theory of fiber migration – need for more fundamental approach and further studies, *Text. Res. J.*, 38, 321

Behery HM and Batavia DH (1971), Effect of fiber initial modulus on its migratory behavior in yarns, *Text. Res. J.*, 41, 812

- Collier BJ and Tortora PG (2001), *Understanding Textiles*, sixth edition, Upper Saddle River, NJ, Prentice Hall
- Demir A and Behery HM (1997), *Synthetic Filament Yarn: Texturing Technology*, Upper Saddle River, NJ, Prentice-Hall
- Farrow B (1956), Extensometric and elastic properties of textile fibers, *J. Text Inst.*, 47, T58
- Hearle JWS and Merchant VB (1962), Interchange of position among the components of a seven-ply structure: mechanism of migration, *J. Text. Inst.*, 53, T537
- Hearle JWS, Gupta BS and Goswami BS (1965), Migration of fibers in yarns. Part V. Combination of mechanisms of migration, *Text. Res. J.*, 35, 972
- Hearle JWS, Grosberg P and Backer S (1969), *Structural Mechanics of Fibers, Yarns and Fabrics*, New York, Wiley-Interscience.
- Meredith R (1945), The tensile behavior of raw cotton and other textile fibers, *J. Text. Inst.*, 36, T107
- Morton WE and Yen KC (1952), The arrangement of fibers in fibro yarn, *J. Text. Inst.*, 43, T60
- Riding G (1964), Filament migration in single yarns, *J. Text. Inst.*, 55, T9
- Townsend PP and Dewhurst J (1964), Fiber migration of viscose rayon staple fiber yarns processed on the Bradford worsted system, *J. Text. Inst.*, 55, T485

## 6.12 Appendix: Glossary and definitions of physical and mechanical properties of fibers, yarns and fabrics

Abstracted from *Dictionary of Fiber and Textile Technology* by Hoechst Celanese (1990)

**Abrasion Resistance:** The ability of a fiber or fabric to withstand surface wear and rubbing.

**Absorbance:** The ability of a substance to transform radiant energy into a different form, usually with a resulting rise in temperature. Mathematically, absorbance is the negative logarithm to the base 10 of transmittance.

**Absorbency:** The ability of one material to take up another material.

**Absorption:** The process of gases or liquids being taken up into the pores of a fiber, yarn, fabric.

**Adsorption:** The attraction of gases, liquids, or solids to surface areas of textile fibers, yarns, fabrics, or any material.

**Aesthetics:** In textiles, properties perceived by touch and sight, such as the hand, color, luster, drape, and texture of fabrics or garments.

**Balanced Cloth:** A term describing a woven fabric with the same size yarn and the same number of threads per inch in both the warp and the filling direction.

**Balanced Twist:** In a plied yarn or cord, an arrangement of twist which will not cause the yarn or cord to twist on itself or kink when held in an open loop.

**Basket Stitch:** In this knit construction purl and plain loops are combined with a preponderance of purl loops in the pattern courses to give a basket-weave effect.

**Basket Weave:** A variation of the plain weave in which two or more warp and filling threads are woven side by side to resemble a plaited basket. Fabrics have a loose construction and a flat appearance and are used for such things as monk's cloth and drapery fabrics.

**Bending Length:** A measure of fabric stiffness based on how the fabric bends in one plane under the force of gravity.

**Bending Modulus:** Maximum stress per unit area that a specimen can withstand without breaking when bent. For fibers, the stress per unit of linear fiber weight required to produce a specified deflection of a fiber.

**Break Factor:** A measure of yarn strength calculated as: (1) the product of breaking strength times indirect yarn number, or (2) the product of breaking strength times the reciprocal of the direct yarn number.

**Breaking Length:** A measure of the breaking strength of a yarn; the calculated length of a specimen whose weight is equal to its breaking load. The breaking length expressed in kilometers is numerically equal to the breaking tenacity expressed in grams-force per tex.

**Breaking Load:** The maximum load (or force) applied to a specimen in a tensile test carried to rupture. It is commonly expressed in grams-force (kilograms-force), pounds, or newtons.

**Breaking Strength:** **1.** The maximum resultant internal force that resists rupture in a tension test. The expression 'breaking strength' is not used for compression tests, bursting tests, or tear resistance tests in textiles. **2.** The load (or force) required to break or rupture a specimen in a tensile test made according to a specified standard procedure.

**Breaking Tenacity:** The tensile stress at rupture of a specimen (fiber, filament, yarn, cord, or similar structure) expressed as newtons per tex, grams-force per tex, or grams-force per denier. The breaking tenacity is calculated from the breaking load and linear density of the unstrained specimen, or obtained directly from tensile testing machines which can be suitably adjusted to indicate tenacity instead of breaking load for specimens of known linear density. Breaking tenacity expressed in grams-force per tex is numerically equal to breaking length expressed in kilometers.

**Bursting Strength:** **1.** The ability of a material to resist rupture by pressure. **2.** The force required to rupture a fabric by distending it with a force applied at right angles to the plane of the fabric under specified conditions. Bursting strength is a measure widely used for knit fabrics, nonwoven fabrics, and felts where the constructions do not lend themselves to tensile tests. The two basic types of bursting tests are the inflated diaphragm method and the ball-burst method.

**Cabled Yarn:** A yarn formed by twisting together two or more plied yarns.

**Cable Twist:** A construction of thread, yarn, cord, or rope in which each successive twist is in the direction opposite the preceding twists; i.e., an S/Z/S OR Z/S/Z construction.

**Carded Yarn:** A cotton yarn that has been carded but not combed. Carded yarns contain a wider range of fiber lengths and, as a result, are not as uniform or as strong as combed yarns. They are considerably cheaper and are used in medium and coarse counts.

**Chenille:** **1.** A yarn with a fuzzy pile protruding from all sides, cut from a woven chenille weft fabric. Chenille yarns are made from all fibers, and they are used as filling in fabrics and for embroidery, fringes, and tassels. **2.** Fabric woven with chenille yarns.

**Circular-Knit Fabric:** A tubular weft-knit fabric made on a circular-knitting machine.

**Combed Yarn:** A yarn produced from combed sliver.

**Commercial Moisture Regain:** An arbitrary value adopted as the moisture regain to be used in calculating the commercial or legal weight of a fiber shipment.

**Core-Spun Yarn:** A yarn made by twisting fibers around a filament previously spun yarn, thus concealing the core. Core yarns are used in sewing thread, blankets, and socks and also to obtain novelty effects in fabrics.

**Cotton Count:** The yarn numbering system based on length and weight originally used for cotton yarns and now employed for most staple yarns spun on the cotton, or short-staple system. It is based on a unit length of 840 yards, and the count of the yarn is equal to the number 840-yard skeins required to weigh 1 pound. Under this system the higher the number, the finer the yarn.

**Crease:** A break or line in a fabric generally caused by a sharp fold. Creases may be either desirable or undesirable, depending upon the situation. A

crease may be intentionally pressed into a fabric by application of pressure and heat and sometimes moisture.

**Crease-Resistant:** A term used to describe a fabric treated chemically to improve its resistance to and recovery from wrinkling.

**Crease Retention:** The ability of a fabric to maintain an inserted crease. Crease retention can be measured subjectively or by the relation of a crease in a subsequent state to the crease in the initial state. Crease retention may be strongly dependent on the conditions of use, e.g., normal wear, washing, or tumble drying.

**Creep:** Deformation that is time-dependent and is exhibited by material subjected to a continuing load. Creep also known as Delayed deformation maybe recoverable or nonrecoverable following removal of the applied load.

**Crepe:** A lightweight fabric characterized by a crinkling surface obtained by the use of: (1) hard-twist filling yarns, (2) chemical treatment, (3) crepe weaves, and (4) embossing.

**Denier:** A weight-per-unit-length measure of any linear material. Officially, it is the number of unit weights of .05 grams per 450-meter length. This is numerically equal to the weight in grams of 9000 meters of the material. Denier is a direct numbering system in which the lower numbers represent the finer sizes and the higher numbers the coarser sizes. In the U.S., the denier system is used for numbering filament yarns (except glass), manufactured fiber staple (but not spun yarns), and tow. In most countries outside the U.S., the denier system has been replaced by the tex system.

The following denier terms are in use:

- **Denier per Filament (dpf):** The denier of an individual continuous filament or an individual staple fiber if it were continuous. In filament yarns, it is the yarn denier divided by the number of filaments.
- **Yarn Denier:** The denier of a filament yarn. It is the product of the denier per filament and the number of filaments in the yarn.

**Density:** The mass per unit volume (usually expressed as grams per cubic centimeter).

**Dimensional Restorability:** The ability of a fabric to be returned to its original dimensions after laundering or dry cleaning, expressed in percent. For example, 2% dimensional restorability means that although a fabric may shrink more than this in washing, it can be restored to within 2% of its original dimensions by ordinary home pressing methods.

**Dimensional Stability:** The ability of textile material to maintain or return to its original geometric configuration.

**Elasticity:** The ability of a strained material to recover its original size and shape immediately after removal of the stress that causes deformation.

**Elastic Limit:** In strength and stretch testing, the load below which the specimen shows elasticity and above which it shows permanent deformation.

**Elastic Recovery:** The degree to which a fiber, yarn, or cord returns to its original size and shape after deformation from stress.

**Elastomers:** Synthetic polymers having properties of natural rubber such as high stretchability and recovery.

**Electrical Resistivity:** The resistance to longitudinal electrical flow through a uniform rod of unit length and unit cross-sectional area.

**Elongation:** The deformation in the direction of load caused by a tensile force. Elongation is measured in units of length (e.g., millimeters, inches) or calculated as a percentage of the original specimen length. Elongation may be measured at any specified load or at the breaking load.

**Elongation at Break:** The increase in length when the last component of the specimen breaks.

**Evenness Testing:** Determination of the variation in weight per unit length and thickness of yarns or fiber aggregates such as roving, silver, or top.

**Extensibility:** The ability of a material to undergo elongation on the application of force. (Also see **Elongation**.)

**Fabric Construction:** The details of structure of fabric, includes such information as style, width, type of knit or weave, threads per inch in warp and fill, and weight of goods.

**Flexural Rigidity:** This measure of a material's resistance to bending is calculated by multiplying the material's weight per unit area by the cube of its bending length.

**Geotextiles:** Manufactured fiber products made into fabrics of various constructions for use in a wide variety of civil engineering applications.

**Helix Angle:** **1.** The angle formed by the path of a ply and the major axis in a yarn or tire cord. **2.** The angle between the tangent to a yarn and the minor axis of the package on which it is wound. Also called wind angle.

**High Modulus:** A term that refers to a material with a higher than normal resistance to deformation.

**High Tenacity:** A term to describe a material with higher than normal tensile strength. (Also see **Tenacity**.)

**Immediate Elastic Deformation:** Recoverable deformation that is essentially independent of time, i.e., occurring in (a time approaching) zero time and recoverable in (a time approaching) zero time after removal of the applied load.

**Impact Resistance:** **1.** The resistance of a material to fracture by a blow, expressed in terms of the amount of energy absorbed before fracture. **2.** In yarn or cord, the ability to withstand instantaneous or rapid rate of loading.

**Initial Modulus:** The slope of the initial straight portion of a stress-strain curve. The modulus is the ratio of the change in stress, expressed in newtons per tex, grams-force per tex, or grams-force per denier, to the change in strain expressed as a fraction of the original length.

**Luster:** The quality of shining with reflected light. With reference to textile materials, the term is frequently associated with the adjectives bright or dull to distinguish between varieties of manufactured fibers.

**Moisture Properties:** All fibers when exposed to the atmosphere pick up some moisture; the quantity varies with the fiber type, temperature, and relative humidity. Measurements are generally made at standard conditions, which are fixed at 65% RH and 70 °F. Moisture content of a fiber or yarn is usually expressed in terms of percentage regain after partial drying.

**Moisture Regain:** The percentage of moisture in a textile material brought into equilibrium with a standard atmosphere after partial drying, calculated as a percentage of the moisture-free weight.

**Natural Fiber:** A class name for various genera of fibers (including filaments) of: (1) animal (i.e., silk and wool); (2) mineral (i.e., asbestos); or (3) vegetable origin (i.e., cotton, flax, jute, and ramie).

**Novelty Yarn:** A yarn produced for a special effect. Novelty yarns are usually uneven in size, varied in color, or modified in appearance by the presence of irregularities deliberately produced during their formation. In singles yarns, the irregularities may be caused by inclusion of knots, loops, curls, slubs, and the like. In plied yarns, the irregularities may be affected by variable delivery of one or more yarn components or by twisting together dissimilar singles yarns. Nub and slub yarns are examples of novelty yarns.

**Optimum Twist:** In spun yarns, a term to describe the amount of twist that gives the maximum breaking strength or the maximum bulk at strength levels acceptable for weaving or knitting.

**Pilling:** The tendency of fibers to work loose from a fabric surface and

form balled or matted particles of fiber that remain attached to the surface of the fabric.

**Plied Yarn:** A yarn formed by twisting together two or more singles yarns in one operation.

**Relaxation:** When a fiber yarn or fabric is held stretched, the stress in it gradually decays. It may drop to limiting value or may disappear completely. This phenomenon is known as relaxation.

**Sizing: 1.** A generic term for compounds that are applied to warp yarn to bind the fiber together and stiffen the yarn to provide abrasion resistance during weaving. Starch, gelatin, oil, wax, and manufactured polymers such as polyvinyl alcohol, polystyrene, polyacrylic acid, and polyacetates are employed. **2.** The process of applying sizing compounds. **3.** The process of weighing sample lengths of yarn to determine the count.

**Skein Break Factor:** The comparative breaking load of a skein of yarn adjusted for the linear density of the yarn expressed in an indirect system. It is the product of the breaking load of the skein and the yarn number expressed in an indirect system (e.g., pounds times cotton count). A statement of the skein break factor must indicate the number of wraps in the skein, if this is not otherwise apparent. Without specifying the number of wraps, a statement of the skein break factor is meaningless.

**Skein Breaking Tenacity:** The skein breaking load divided by the product of the yarn number in a direct numbering system and the number of stands placed under the tension (twice the number of wraps in the skein), preferably expressed in newtons per tex.

**Static:** An accumulation of negative or positive electricity on the surface of fibers or fabrics because of inadequate electrical dissipation during processing. Static results in an electrical attraction or repulsion of the fibers relative to themselves, to machine parts, or to other materials, preventing the fiber from traveling in a normal path in the process.

**Stiffness:** The property of a fiber or fabric to resist bending or to carry a load without deformation. It is based on the fiber modulus.

**Tenacity:** The tensile stress when expressed as force per unit linear density of the unstrained specimen (e.g., grams-force per denier or newtons per tex).

**Tensile Strain:** The relative length of deformation exhibited by a specimen subjected to a tensile force. Strain may be expressed as a fraction of the nominal gauge length or as a percentage. (Also see **Elongation**.)

**Tensile Strength: 1.** In general, the strength shown by a specimen subjected to tension as distinct from torsion, compression, or shear. **2.** Specifically, the

maximum tensile stress expressed in force per unit cross-sectional area of the unstrained specimen, e.g., kilograms per square millimeter, pounds per square inch. (For maximum stress per unit linear density.)

**Tensile Stress:** The resistance to deformation developed within a specimen subjected to tension by external force. The tensile stress is commonly expressed in two ways, either as (1) the tensile strength, i.e., the force per unit cross-sectional area of the unstrained specimen, or as (2) tenacity, i.e., the force per unit linear density of the unstrained specimen. The latter is more frequently used in textile testing.

**Tex: 1.** A unit for expressing linear density, equal to the weight in grams of 1 kilometer of yarn, filament fiber, or other textile strand. **2.** The system of yarn numbering based on the use of tex units.

**The Cord:** A textile material used to impart the flex resistance necessary for the reinforcement. Tire yarns of polyester, rayon, nylon, aramid, glass, or steel are twisted to 5 to 12 turns per inch. Two or more of these twisted yarns are twisted together in the opposite direction to obtain a cabled tire cord. The twist level required depends on the material, the yarn linear density, and the particular application of the cord. Normally tire cords are twisted to about the same degree in the S and Z directions, which means that the net effect is almost zero twist in the finished cord.

**Twist Multiplier:** The ratio of turns per inch to the square root of the yarn count.

# Part II

Advances in particular yarn spinning  
technologies

---



**Abstract:** Ring spinning occupies a unique position among the various spinning technologies because of its versatility in producing stronger yarns from very fine to coarse counts from many fibres. Ever since its inception, it has undergone developments at a snail's pace. The productivity of ring spinning has improved over the years, yet it is very much lower compared to that of other spinning systems. The recent developments in ring spinning are mainly concerned with improvements in drive systems, drafting arrangement, design aspects of ring and traveller, machine monitoring, automation that includes roving stop motion, roving bobbin transfer, doffing and cop transfer to winding. Other developments that have taken place such as compact, solo, double-rove and core-sheath spinning, etc., have improved the versatility of ring spinning without change in the very basic concept of ring spinning.

**Key words:** automation, bobbin, compact, drafting, drives, doffing, monitoring, ring, roving, start-up, transport, traveller.

## 7.1 Introduction

Ring spinning celebrated its bicentenary in 2008 but, unlike blow-room, carding and drawing machines, the basic shape of the ring-spinning machine has not undergone much of a change. The capacity of ring-spinning machines has increased greatly, now housing 1680 spindles. In addition, there have been developments in variants of ring spinning such as 'double-rove spinning', 'solo-spinning', 'core-sheath spinning' catering for hard and soft cores, and 'compact ring spinning'. There have also been improvements in productivity and ease of operation, process and product monitoring, auto-doffing, the linking of roving and winding machines and in yarn quality.

The productivity of ring spinning has improved over the last two decades, but not at a satisfactory pace, being several degrees lower than that of other spinning systems. The productivity of ring spinning is limited by the sliding friction of the traveller that determines its wear and yarn breaks, despite the incorporation of new designs of rings and travellers made with new materials and finishes. No major breakthrough in productivity appears likely in the near future because the traveller is a restrictive factor. A traveller that slides at high speeds develops considerable frictional heat, and it is extremely difficult to dissipate this heat in the short time available. Nevertheless, ring

spinning is unique among the various commercial spinning systems, setting the benchmark for yarn strength. Ring spinning is the most flexible system with regard to the fibres which can be used and the number of yarn counts that can be spun, which no other spinning system so far has been able to challenge.

## 7.2 Main technologies of spinning

The major technologies of staple fibre spinning are ring, rotor, air-jet and open-end friction. These technologies are all used commercially and compete with each other for their share of the market. With the largest share by far, ring spinning accounts for more than 80% of the market, mainly catering for apparel applications, both knitted and woven, tents, and tarpaulins. Air-jet yarns find applications in shirting and ladies' outerwear. Open-end (OE) friction yarns find applications in technical and recycling products, carpets and home textiles. Rotor yarns are used for apparel, especially denim and knitwear. A brief comparison of these spun-yarn technologies is shown in Table 7.1.

## 7.3 Advantages and limitations of ring spinning

The inherent strength of ring spinning lies in its ability to process a wide range of fibres, and to produce an extensive range of yarn counts of the highest strength. The fundamental limitation of ring spinning is its low productivity that can be traced back to its complete reliance for twisting the fibre strand on a miniature element called a 'traveller', weighing 12.5 to 280 mg, which can only slide, not roll. The sliding velocity of the traveller is currently limited to <50 m/s because if it was any higher, with the current design of travellers and the racetrack on which they slide (the 'ring'), the travellers would not be able to withstand the kind of temperature rise they would experience due to frictional heating. All attempts to dissipate heat from the travellers to their surroundings through conduction, convection and radiation are insufficient when the traveller speed exceeds 42–50 m/s (depending on traveller and ring combinations) with a maximum spindle rotation speed of 22,000 rpm.

Other major limitations of ring spinning are associated with the yarn quality it produces, namely high yarn hairiness (especially hairs longer than 3 mm) and irregularity. The latter is characteristic of roller drafting, which is unable to flawlessly regulate the movement of short fibres. The former is due to the spinning geometry, principally the spreading of the fibre strand that occurs at the front roller nip. With the introduction of compaction of the fibre strand in the spinning region (using various compact spinning technologies), the problem of excessive hairiness of ring-spun yarns was a thing of the past

Table 7.1 Comparison of major staple fibre spinning systems

Spinning system	Drafting	Strength impartation	Fibres	Count range, Ne	Speed, m/min
Ring	Roller	Mechanical process, true twist, high fibre migration	Cotton, synthetic, wool, few technical fibres	4–160	25
Rotor	Opening roller and aerodynamic	Mechanical process, true twist, surface with wrappers, low fibre migration	Cotton and blends	5–40	200
Air-jet (twin nozzles)	Roller	Aerodynamic process, false-twist, core twistless, surface with wrappers, less wrapper fibres, low fibre migration	Synthetics, combed cotton	15–60	300
Air-jet (single nozzle)	Roller	Aerodynamic process, false-twist, core twistless, surface with wrappers, more wrapper fibres, low fibre migration	Synthetics and cotton	8–40	400
OE-friction	Opening roller and aerodynamic	Mechanical process, true twist, low fibre migration	Technical and speciality, synthetic, bast, wool fibres	0.18–5	300

for spinners who could afford to have compact ring-spinning machines. But the problem of hairiness variation along the length of the yarn still remains unresolved and it will remain so while there is no individual control of fibres during drafting.

## 7.4 Developments in ring spinning

There are two categories of developments in ring spinning: (1) developments in the machines with regard to drives, automation, monitoring (process and machine) and the linking of the ring-spinning machine to roving and winding machines to improve productivity and process efficiency for classical, single ring-spun yarns; and (2) developments leading to derivatives or offshoots of ring-spinning technologies such as compact, nozzle-ring, double-rove, solo and core-sheath spinning systems that produce non-classical ring yarns.

### 7.4.1 Roving guide drive

In the conventional roving guide, the wear on the roller at the extreme ends of strokes is quite high due to the sine-curve-like movement of the guide. Zinser has developed a roving guide, where the movement of the guide is a combination of small straight lines that evens out wear on the top roller over the whole traversing width (Fig. 7.1). With an improved roving guide drive, wear on the top drafting cylinders is reduced, increasing the service life of the top rollers.

### 7.4.2 Delayed start-up of drafting rollers

The drive for the drafting rollers is a rigid one (by gears) and the spindle is driven by a flexible drive (belt). The initial belt tensions on both sides of the spindle are the same while the machine is at rest. When the ring-spinning machine is started, the belt tension in the forward direction increases, and at the back it decreases enough to build up the required torque on the spindle. Additional slackness present on the spindle belt compounds the problem. The acceleration of the spindle lags behind that of the drafting rollers and the yarn slackens; if it slackens too much, this might lead to balloon instability and the end breaks. Delaying the starting of the drafting rollers by a few seconds would solve this problem. In the Marzoli ring-spinning machine, at the beginning of cop build-up, the starting of the drafting rollers is delayed so that the spindle starts to rotate first, which tightens the initial yarn ends (Marzoli, 2009).

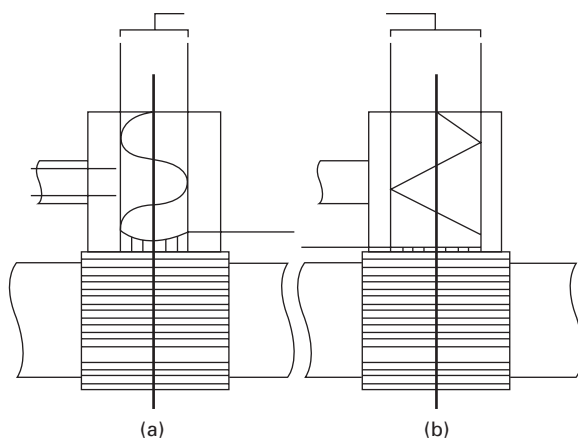

7.1 Roving guides: (a) conventional, and (b) new roving guide in Zinser ring spinning machine (courtesy of Zinser).

### 7.4.3 Modification in drafting arrangement

Conventional bridge-shaped cradles are flat with a step guide. New bridge cradles are designed with a convex shape (arc). Rieter's Ri-Q bridge (Rieter, 2009) and Marzoli's Arco bridge (Marzoli, 2009) are arc-type cradles (Fig. 7.2). With the new design, the top and bottom aprons assume concave and convex shapes respectively in the working region and are kept at a higher tension compared to that when running on flat cradles. This type of arrangement extends the pressure fields on the fibres held by the middle rollers close to the front rollers, improving the guidance of short fibres. When spinning finer yarns, fewer fibres are drafted and arc-shaped cradles might be useful. Arco bridge cradles are recommended for compact and finer yarns. It has been shown that Rieter's Ri-Q bridge reduces yarn CV% and imperfections (thick and thin places) by 40% and improves yarn strength by 18%.

A new drafting system proposed by Chen *et al.* (2000) is shown schematically in Fig. 7.3. The top apron extends into the back zone; at its extreme back end it pushes and deflects the fibre strand down from the back roller. This arrangement gives improved fibre guidance for short fibres and hence an improvement in the evenness of the yarn is obtained.

### 7.4.4 Rotating ring

A new system, termed 'magnetic spinning', has been developed in which the ring is a magnetically suspended rotor kept inside a fixed stator. The ring can freely carry the pigtail/traveller at 40,000 rpm. The stator is equipped with four magnetic actuators that always keep the ring in its central position.

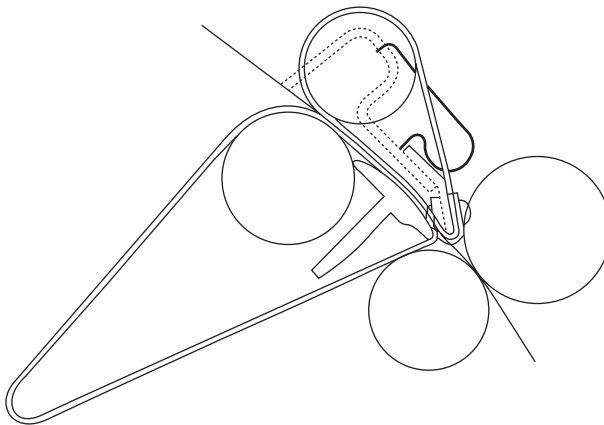

7.2 Deflection of bottom apron: Arco Bridge of Marzoli (courtesy of Marzoli).

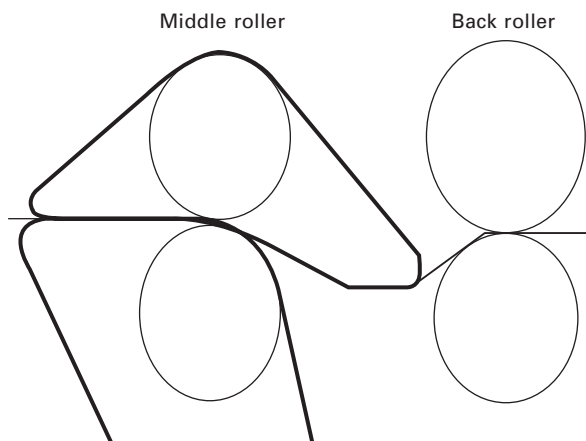

7.3 Top apron extending into the back zone (Chen *et al.*, 2000).

This system is yet to be commercialized. The limitations of the system are discussed in the future trends section of Chapter 2.

#### 7.4.5 Ring and traveller

The ring is the race track over which the traveller has to revolve to impart twist to the yarn balloon. Running at a speed of 110–170 km/hour, the traveller generates heat at its interface with the inner edge of the ring. As the traveller is very light, its temperature can reach as high as 300°C in spite of heat losses due to conduction and convection, leading to localized melting and rapid wear. The problem is aggravated with increased spindle speed and ring diameter.

Considerable research work has been carried out by the ring and traveller manufacturers, aimed at reducing the frictional wear of the ring and travellers and increasing heat conduction at the traveller–ring interface. This has resulted in the use of carbon-rich steel, lubricated rings, ceramic rings, special finishes (diffusion treatment, nickel plating) and new designs of ring and traveller combinations with an increased area of contact. Other developments leading to a revolving ring are yet to be commercialized. The travellers used for short staple spinning are C-type on a low crown ring/T-ring, Orbit and SU (Fig. 7.4). The area of contact between the ring and traveller is greater in the case of SU and Orbit types, providing better heat dissipation. The traveller describes an up-and-down motion and tilts in the radial and tangential planes continuously due to the variation in the balloon size and its tension and also the change in the lead angle with the ring rail movement. In SU and Orbit rings, the design of the ring itself provides a certain balancing effect on the traveller while it is tilting/oscillating. The resultant lifting force on the traveller



7.4 Types of ring and traveller (courtesy of Bracker).

**f Flat wire**

Good seating on the ring, hence low hairiness results. Suitable for fine cotton yarn and viscose

**dr Semi-round wire**

For blends, cotton and synthetics. Good results with low twisted (knitting) yarn. For high speeds

**udr Ultra semi-round wire**

For cotton, blends and synthetics. This wide profile offers large contact surface and good heat conduction at high speeds

**fr Flat round (combined profiles)**

For acrylics, special synthetics and core yarn. Flat toe, round yarn passage, for higher speed

**r Round wire**

For wool, synthetics and core yarn, for lower speeds. Small area of contact with ring leads to instability

**drh Semi-round high**

Special section, designed for US travellers



7.5 Traveller cross-sections (courtesy of Bracker).

due to winding and balloon tension ( $T_L$ ) is balanced by another resultant downward force ( $T_D$ ) that arises due to the action of centrifugal force on the traveller ( $C$ ) and the normal reaction force on the traveller ( $N$ ) by the ring at the ring–traveller interface. Travellers are made with different cross-sections (wire profiles) suitable for different fibres and yarns (Fig. 7.5).

The fibres protruding from the yarn body (hairs) are crushed between the ring and traveller and form a steady lubricating film. The fibre lubrication prevents metal-to-metal contact and reduces the friction coefficient

considerably, in extreme cases from 0.12 to 0.08, depending on the fibre (dry or strong wax-containing cotton or softening agents on synthetics). With new rings, metal-to-metal contact occurs at the ring–traveller interface and gives rise to a high friction coefficient that results in increased yarn tension and breaks. When rings are changed for new ones, it is usual practice to run the spindle at lower speeds then progressively increase the speed over a period of a few days, called ‘running-in’, to generate fibre lubricants and deposit them on the ring. A heavy traveller on a fibre-lubricated ring can generate the same friction drag on the traveller as a lighter traveller sliding on a non-fibre-lubricated ring.

#### 7.4.6 Drive systems

Changing the yarn count and twist (level and directions) can now be carried out automatically without any mechanical intervention (change of gears). Another trend is the division of drafting systems on long ring-spinning machines into two halves, each driven independently. Ring-spinning machines such as the Rieter G35 Flexi start and the Marzoli MPT-N and MP1-N have these features. Front and back rollers are driven individually by frequency-controlled synchronous motors running separately on the two halves of the machine. This facilitates processing two separate lots of fibres that differ in twist and yarn count. A combination of these two methods offers advantages such as:

- Time-saving during start-up and doff of the machine
- Spinning of small lots or samples
- Setting of twist, total draft and yarn count by the push of a button.

As an example of this, the drive features of the Marzoli ring-spinning machine are illustrated in Fig. 7.6. The main motor with a relative inverter drives only the spindles. An asynchronous motor drives the ring rail. The drafting rollers have two separate drives, one on each side of the spinning machine, through asynchronous motors. On each side, one motor drives the front drafting rollers and the other one drives the middle and back drafting rollers. The production parameters, namely main draft, twist and shape of the bobbin, must be entered at the control panel, making any gear changing redundant; this ensures fast and precise control of important parameters, thereby increasing the flexibility of the ring-spinning machine. There is the option to produce slub, multi-twist and multi-count yarn.

#### 7.4.7 Spindle drives

Two types of system are employed to drive the spindles, namely a four-spindle group drive with tapes (Fig. 7.7) and a tangential belt drive (Fig.

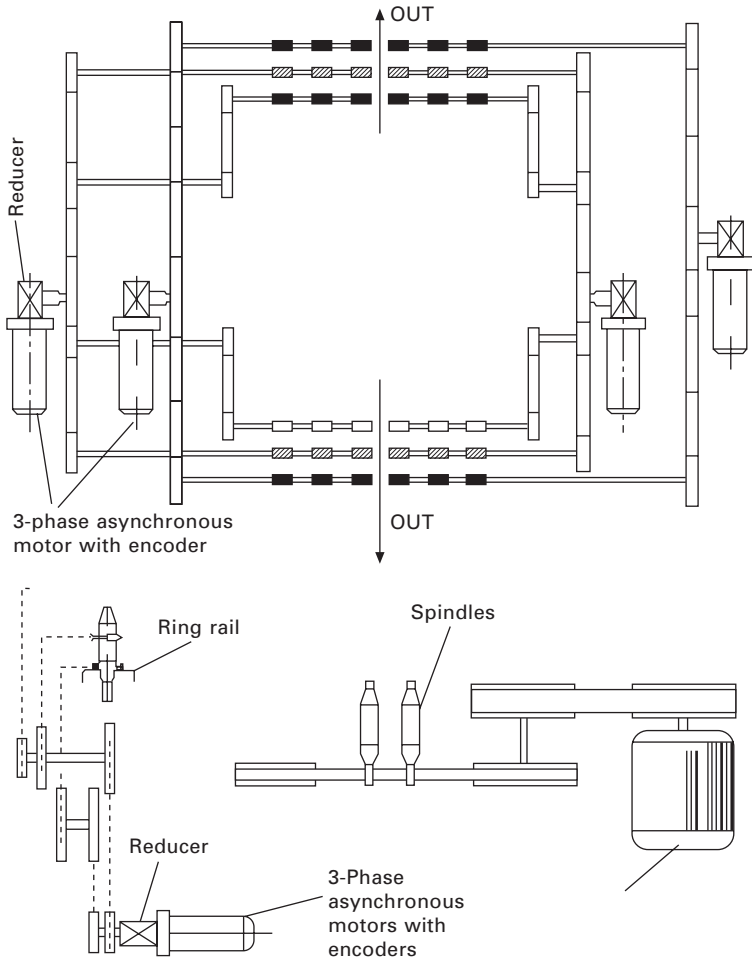

7.6 New drive system for ring spinning machine – Marzoli MPT-N (courtesy of Marzoli).

7.8). In the former, a pulley (Jockey pulley) mounted on the main shaft of the spinning machine drives two spindles on one side of the machine and a further two spindles on the other side of the machine by means of a flexible tape/belt. Two tension rollers on either side of the pulley ensure an even, firm tension on the belt. In the tangential belt drive, a belt extends from the motor past the inner side of each spindle. A number of tension rollers are placed along the belt to press against it and ensure a constant tension on the belt for all the spindles. However, there is a possibility of non-uniform tension on the belt due to variations at the locations of the tension rollers. This might lead to a variation in yarn twist on each spindle. Tangential belt

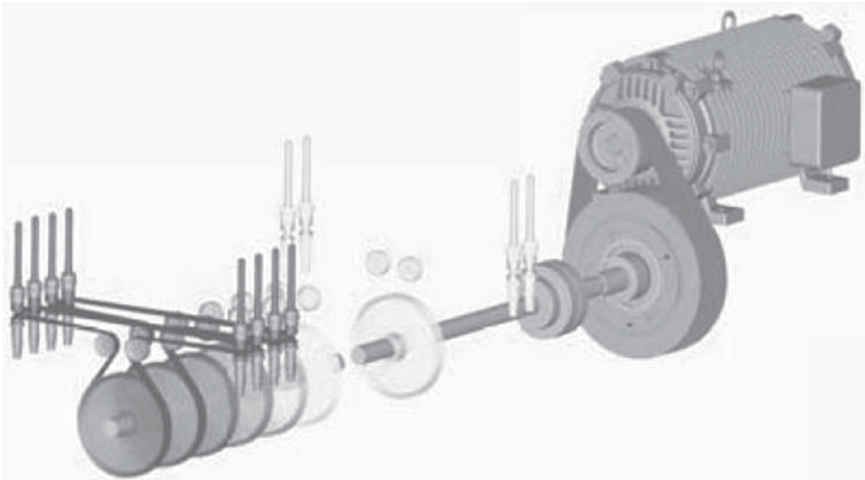

7.7 Four-spindle belt drive (courtesy of Rieter).

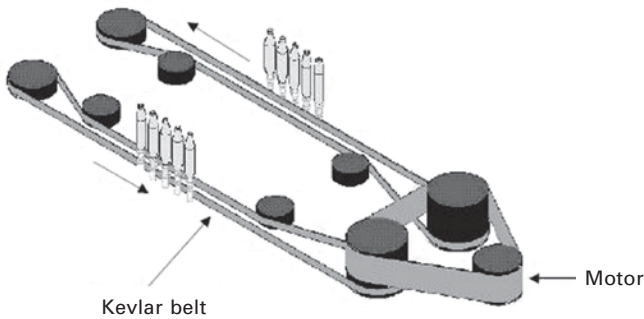

7.8 Tangential spindle drive (courtesy of Marzoli).

drives are available in three basic forms: single, double and grouped. If a belt breaks, production is affected on a large number of spindles.

The four-spindle belt drive was employed for many decades, and then the tangential drive came into existence. However, there is now a perceptible trend of users going back to the time-tested four-spindle drive. The four-spindle drive offers a greater angle of wrap around the spindle wharves by manipulating the position of the tension pulleys. This ensures less slippage on the belt, and provides constant rotation speeds to the spindles over the total length of the machine, regardless of the number of spindles on the machine. Furthermore, it leads to less tension on the belt and hence a lower energy consumption. In the event of a belt breaking, only the four spindles are affected, and it is also a quick job to replace it.

### 7.4.8 Timing belt

Timing belts with toothed wheels are replacing gears in industrial drive applications. A timing-belt drive is as rugged and accurate as a gear drive. A timing-belt drive is a positive drive; the belt is made of rubberized fabric with steel wire to take the tension. It does not stretch or slip, and consequently transmits power at a constant angular velocity. Belts require no initial tension, operate over a wide range of speeds, have >99% efficiency and require no lubrication. A timing belt driving the drafting rollers is shown in Fig. 7.9. Ergonomically, a timing-belt drive is very simple: a toothed belt tensioned by a pulley/roller connects the input and output elements. Changing the speed of the machine is easier with the timing-belt drive than with the gear drive. Gear drives require carrier gears if the input and output elements are some distance away. The positioning of carrier gears needs careful consideration, based on the rotational directions of the driver and driven elements. Furthermore, a gear drive experiences interference, the phenomenon of transmitting fluctuating speeds for various reasons such as the accumulation of fibres and dust on gear teeth, the breaking or wearing of teeth, and improper meshing of the gears by deflection of the shaft or misalignment of the gears. These types of problem are not seen in timing-belt drives.

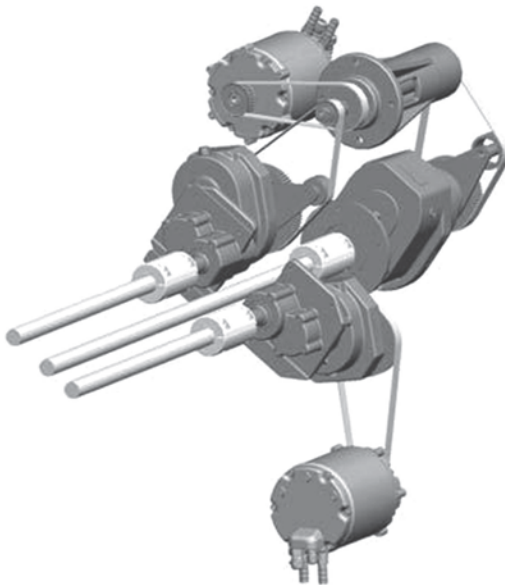

7.9 Servo motor drives for drafting system (courtesy of Rieter).

### 7.4.9 Elimination of reserve winding with yarn grip during doffing

Reserve or under winding of yarn is carried out before doffing. The length of yarn wound in this operation is more than that required for joining the yarn when the spinning machine restarts with empty bobbins. The excess yarn must be removed manually or mechanically and this portion of material is disposed of as hard waste. Furthermore, this leads to ends-down, fly formation in the spinning area and yarn quality deterioration. Therefore the recent trend is to eliminate reserve winding; one such design for this is Rieter's SERVO grip. The sequence of operations for Servogrip is illustrated in Fig. 7.10 which shows (1) the ring rail at top position, (2) the Servogrip opens when the ring rail is lowered, the spindle rotates very slowly, and winds a short length of yarn onto the Servogrip, (3) a clamping cap closes and clutches the yarn, (4) the clamping cap moves up, (5) the clamping cap moves down, and (6) the clamping cap returns to its original position.

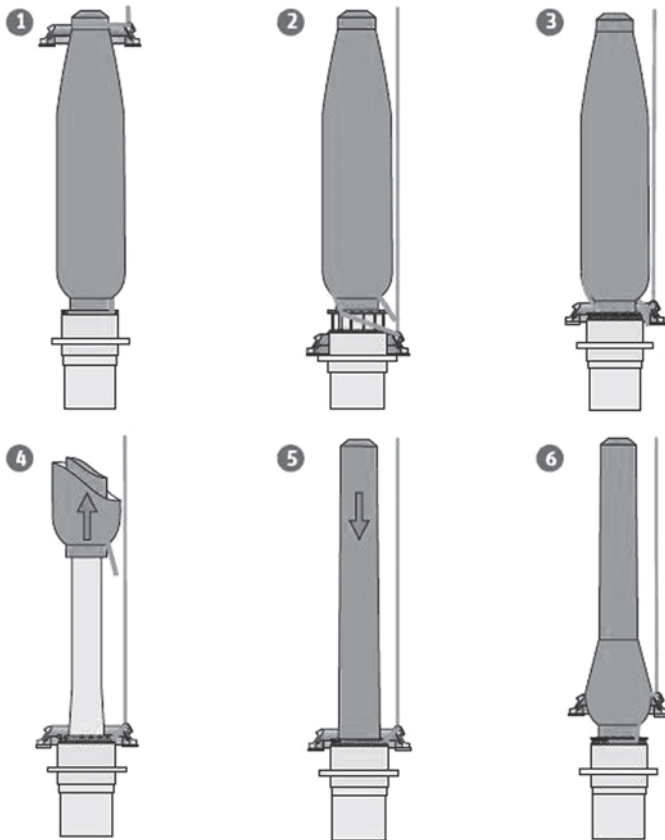

7.10 Elimination of reserve windings: SERVO grip of Rieter (courtesy of Rieter).

(4) the full cop is removed, (5) a new bobbin is inserted onto the spindle and grips the yarn, and (6) the winding goes onto the new bobbin while the short length of yarn in the Servogrip remains throughout the cop build-up. Only at the next cop change is the length of yarn released and pulled off with the full cop, leaving no yarn residues on the spindle.

#### 7.4.10 Closed-circuit cooling system

A closed-circuit cooling system is integrated into the machine, whereby waste heat from the motors and frequency converters passes over an internal heat exchanger and then directly into the exhaust air ducts of the air-conditioning system. This reduces the load on the air-conditioning system, which can then provide a constant environment for the spinning premises.

#### 7.4.11 Automation in ring-spinning machines

Automation in ring spinning consists of:

- Transferring the roving bobbin into the creel of the ring-spinning machine
- Stopping the roving feed when an end breaks
- Machine and production monitoring
- Doffing
- Transporting cops to the winder.

##### *Roving bobbin transfer*

On the creel of the ring-spinning machine, optical sensors are placed near each of the roving bobbins. Full roving bobbins move in the area near the ring-spinning machine. If a bobbin is exhausted, the movement of roving bobbins is stopped and a T-shaped lever, with pegs at each end for holding the roving bobbin, comes into action. One side of that lever takes the new bobbin and the other end takes the empty roving bobbin from the ring-spinning machine's creel. The lever then rotates through 180° and transfers the fully wound bobbin to the ring-spinning machine's creel and the empty bobbin to a creel nearby. The operator only joins the roving ends, which saves them time and reduces roving bobbin run-out time caused by operator error in a manual system.

##### *Transfer of roving bobbin from the roving machine to the creel of the ring-spinning machine*

Most machine manufacturers offer the automatic transport of roving bobbins to the creel of the ring-spinning machine. A design offered by Oerlikon

Schlafhorst on the Zinser 351 ring-spinning machine (Schlafhorst, 2009) has four rows of creels, which are designed as transport rails driven by trolley trains (Figs 7.11 and 7.12). Three rows of creels are in working positions and the fourth one serves as a reserve. If one of the rows of working creels runs out of roving bobbins, the next one automatically takes over as the supply creel. The operator of the ring-spinning machine has to join up roving ends to the waiting full bobbins. By simply pressing a button on the ring-spinning



7.11 Automatic transfer of roving bobbin with rows of creel: CimTrack 4 (courtesy of Oerlikon Schlafhorst Zinser).



7.12 Ring spinning machine with automatic roving bobbin transfer (courtesy of Oerlikon Schlafhorst Zinser).

machine, the trolley with empty tubes is sent back and a new full trolley train is requested. The empty trolley train now enters the cleaning station, then waits in the storage section to be filled again. The control centre sends a new full trolley train to the ring-spinning machine. Two modules are offered: a stand-alone module integrated into the transport system or a tube cleaner integrated into the roving machine.

During the manual transport of roving bobbins, it is possible to mix up different lots of bobbins, or to damage the outer layers of roving. Most of the damage to the yarn is not visible until the fabrics are finished. The intermediate storage of bobbins also results in soiling. Automatic bobbin transfer does not have these limitations. It has a high potential for saving labour costs, especially for coarser yarn counts, since it only takes a short time to replenish a full bobbin. The techno-economics of automatic bobbin transfer have to be taken into account before installing it.

### *Roving stop motion*

When a yarn breaks during spinning, the drafting rollers continue to process the fibre strand, and fibres are sucked into an aspirator and go as waste. In poor spinning conditions (high relative humidity), the drafted fibres lick on to the drafting rollers and form a lap. This can damage the top rollers and aprons and causes ends-down on the neighbouring spindles. The removal of roller lap also causes additional problems. All the costs (labour, power and indirect costs) incurred in converting the fibres into roving become unproductive. It would be desirable to have a roving stop motion that interrupts the flow of fibres from the time an end breaks until joining is carried out. Roving stop motions can be provided as part of the travelling device or as assemblies at each individual position. The former is more economical but the roving stop would not be immediate as in the case of integrated equipment.

Marzoli has brought out a roving stop motion in which the roving is locked at the back of the drafting system as soon as a yarn break is detected by a sensor. The sensor, which is placed below the lappet, senses the presence of yarn at each spindle position. Marzoli's roving stop mechanism is illustrated in Fig. 7.13. Additionally, the sensors at each position are used as data collection units for the status of each spinning position. This has potential applications for machine monitoring and production data acquisition.

### *Monitoring*

Ring-spinning monitoring systems are available for obtaining data about individual machines, individual blends or the complete ring-spinning installation from printed reports or from screen displays, including spindle rpm, mean yarn twist, production data (machine and spindle), machine

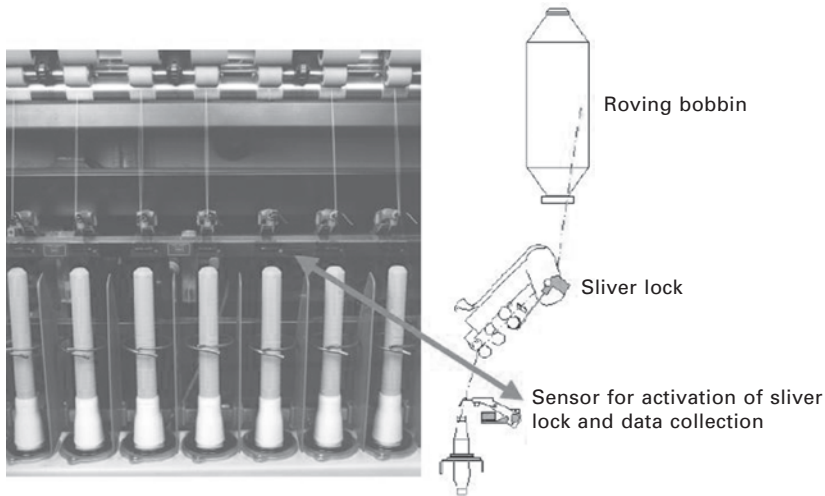

7.13 Roving stop motion (courtesy of Marzoli).

efficiency and downtime, doff time, number of doffs, ends-down and mean period for each end-down. Many sensors are used to monitor different parts of the machine to acquire different data.

A travelling sensor based on the principle of magnetic induction moves continually back and forth at about ring rail level on each side of the ring-spinning machine. If a yarn breaks, the sensor emits a pulse indicating an end-down, while simultaneously identifying the spindle by its code number. This sensor registers the yarn break at one spindle several times before the position is returned to production. The time for which an end remains down is computed. Another sensor, fitted to a roller corresponding to the front roller, detects delivery speed and machine downtime; a further sensor detects the number of doffs and the time taken for each doff. All this information is passed on to a computer for displaying, printing and evaluating over a given period.

#### *Centralized control of spinning parameters and data retrieval*

Rieter's MEMO set product module stores spinning parameters for up to 18 different yarns. The data are available at all times and can be retrieved and processed. The parameters are downloaded directly from a laptop, and transferred between several spinning machines. Machine functions, spindle drive, drafting arrangements, auto doffing, and traveller cleaner's details are all centrally controlled and always available on the display unit. Real-time information is made available regarding output and machine status. Adjustments to production parameters, e.g. for yarn twist, are possible via

a keyboard. When changing the blend, modifications to machine data can be made quickly. The time remaining to the next doffing process is available on a display, which can facilitate the allocation of personnel.

### *Automatic doffing*

There are two types of automatic doffing for ring-spinning machines: stationary and travelling devices; the former is mostly used in new machines. After completion of a doff, the doffer, which contains empty ring bobbins and also the provision for holding the fully wound bobbins, rises from below. Fully wound cops are then gripped by the doffer and transferred to it, and then empty bobbins are transferred from the doffer to the spindle of the ring-spinning machine. Subsequently the doffer comes back to its original position and transfers all the full cops to a conveyor belt, which might be used to transfer them to the winding machine.

### *Automatic cop transport to winding*

Automatic cop transport to winding can be classified into (1) intermediate transport between spinning and winding sections/departments and (2) direct link to a specific winding machine. In an intermediate transport system, the transport devices take up the boxes of full cops coded according to their contents, and deliver them to a distribution station. This station directs the boxes to the cop preparing unit of the corresponding winding machine. The empty tubes are deposited in other boxes and returned via a second conveyor system to the ring-spinning room. Intermediate transport systems are very flexible, rapidly adaptable and less dependent on the layout of the building that houses them. However, they can be rather complex, costly and liable to faults.

With the direct link system, the ring-spinning machine and the winding machine can be coupled to form a production unit. The cops doffed at the ring-spinning machine are passed to the winding machine. The transfer speed must correspond to the production rate of the winding machine; hence it is slow. Empty bobbins are returned to the loading station of the auto doffer at the ring-spinning machine. The number of winding units chosen should be such that the cops delivered after one doff have just been rewound when the cops from the next doff become available. The requirement for synchronizing each machine is difficult to achieve when products are changed frequently.

## 7.4.12 Technologies to produce core yarns

For processing both elastic and hard filaments, attachments to feed the filaments into the front roller nip are available that can be retrofitted on

existing ring-spinning machines. In the case of manufacturing elastic filament core spun yarn, the control of stretch or pre-draft on the filaments has to be carried out precisely using positively driven rollers that support the filament package. Selection of the appropriate roughness and finish for the rollers' surface is critical to avoid stick-slip of filaments. Servo motors are also used to drive guide rollers. For processing hard core filaments, a special creel for supporting and unwinding filament cops is installed. With very fine yarn, precise centring of the filament in the resultant composite yarn is difficult. A floating filament guide system with an intermediate roving guide bar is used to ensure the relative positions of filament and roving. One of the main defects of core spinning is the production of yarn without any filaments when the filaments break. Different systems are available to avoid this. Mobile filament detectors can be used, one on each side of the machine. An individual filament detector, together with a roving stop mechanism, would be ideal and could be adapted to stop the production of a particular spindle when the filament broke. Figures 7.14 and 7.15 illustrate a ring-spinning machine for producing core yarns.

#### 7.4.13 Double roving spinning system

In a double roving spinning system (Fig. 7.16), two rovings are drafted separately and twisted together. The resulting yarn looks like a two-ply yarn, but with unidirectional twist. Such yarns have lower hairiness and pilling tendencies, are more even with less thin places, and have a smooth yarn surface offering better colour and printing definition in woven fabrics. Double rove yarns were primarily developed to replace two-ply yarns in the worsted sector. Now this system is also available in the short staple sector. Since the size of the spinning triangle is highly critical in short staple spinning to avoid end breaks, an adjustable condenser is placed in the back draft zone to fine-tune the distance between the two rovings. The system can be adapted for existing ring-spinning machines, cotton and worsted. Pinter has designed a system that works with core-spun and fancy-spun yarns.

#### 7.4.14 Ring spinning machine with multiple spinning systems

It is possible to produce multi-count and multi-twist yarns with independent servo drives to the drafting rollers, by varying the main draft and front roller speed respectively. A combination of both can produce slub/fancy yarns. It is possible to produce a wide range of yarn structures with fancy appearance using inbuilt programs that control the servo motors in ring spinning. Such ring-spinning machines are in operation all around the world. Pinter has

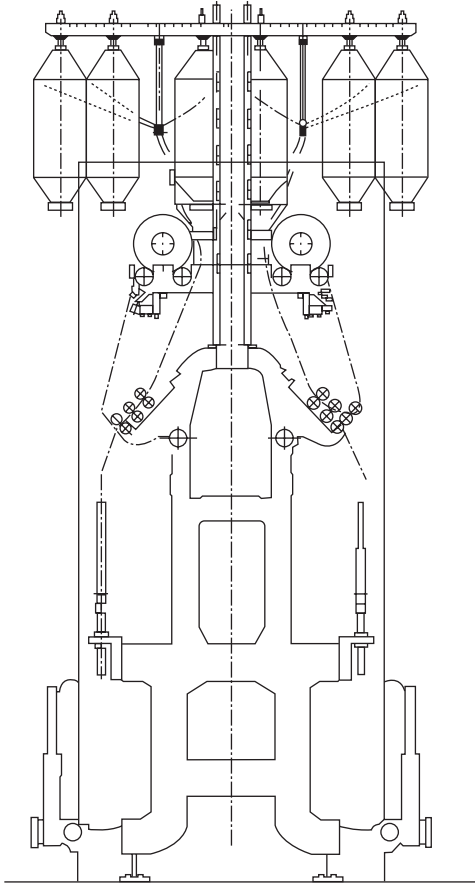

7.14 Elastic core attachment in ring spinning machine (courtesy of Marzoli).

developed a small ring-spinning machine – ‘Merlin’ – with six or 48 spindles that allow it to work with a range of fibres to produce all types of special yarns and their combinations: slub (multi-count and multi-twist), core spun, devore and double rove yarns. The machine is fully automated so requires no change of gears to modify draft, twist and speed.

#### 7.4.15 Technologies to produce low hairiness yarns

Technologies that are available to produce low hairiness yarns using ring-spinning machines can be categorized into (1) the use of a nozzle after the spinning triangle; and (2) modification of the spinning triangle.

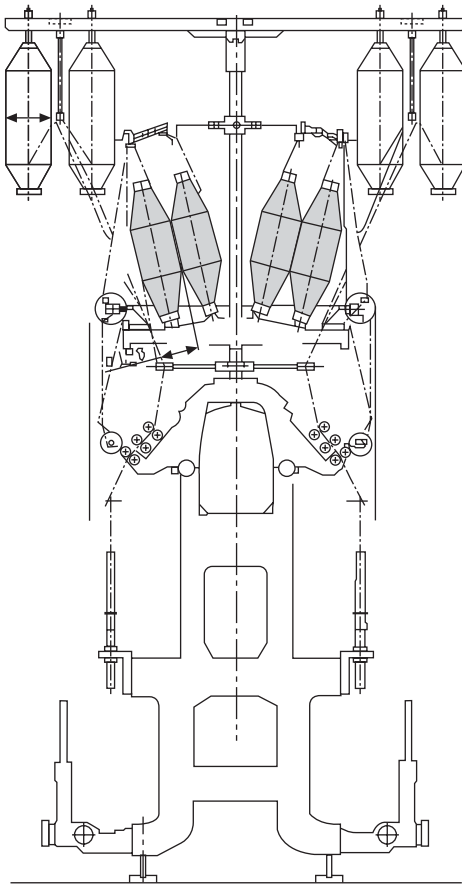

7.15 Hard core filament attachment in ring spinning machine (courtesy of Marzoli).

*Nozzle ring spinning*

Nozzle-ring or jet-ring spinning is a recent innovation, which has until now been in the research stage. An air nozzle is placed below the front roller and the issuing fibre strand passes through it before reaching the yarn guide eye (Fig. 7.17). The nozzle has to be placed such that the front roller nip, the axes of the nozzle and the yarn lie in a straight line. Compressed air is supplied to the nozzle through pipes with a pressure regulator and an air filter. Since the nozzle is the heart of the process of reducing yarn hairiness, its design plays a vital role. It is an air-vortex type of nozzle which creates a swirling airflow as shown in Fig. 7.18. A Z-nozzle should be used for Z-twisted yarn. The airflow issues from the nozzle in an upward direction, i.e. against the direction of yarn movement. The yarn coming from the front roller is

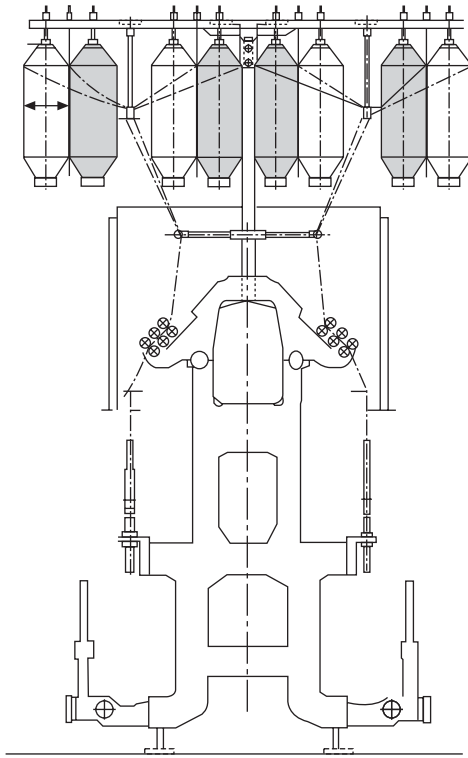

7.16 Double roving ring spinning machine (courtesy of Marzoli).

partially untwisted on the upstream and then re-twisted on the downstream, i.e. the yarn undergoes a false twisting action. The swirling airflow has three components, namely tangential, axial and radial, the last being very low in magnitude. The air-drag forces acting on the protruding hairs fold and wrap them around the yarn surface (Fig. 7.19). The distance between the nozzle and the front roller, the angle of air inlets and the yarn channel diameter play decisive roles in the efficiency of hairiness reduction. An operating air pressure around 0.5 bar (gauge) is found to be sufficient to reduce it. Placing the nozzle too close to the front roller would disturb the spinning triangle and affect the yarn formation process itself. Generally, the distance between the nozzle and the front roller is around 10 cm for the best results. The air nozzle preferentially reduces longer hairs, especially S3 hairs (Table 7.2). The hairiness reduction may reach 50%.

Nozzle-ring spinning is in its nascent stage. Many issues have to be addressed, such as (1) joining yarns during spinning by a suitable means, (2) its precise positioning in the spinning region, (3) making the cost of the nozzle affordable, and (4) reducing air consumption below 0.5 bar (gauge), before this technology can be commercialized.

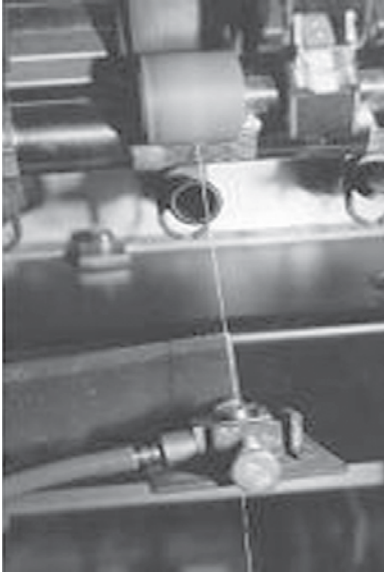

7.17 Photograph of the nozzle assembly mounted on a ring spinning machine (courtesy of A. Patnaik, PhD thesis).

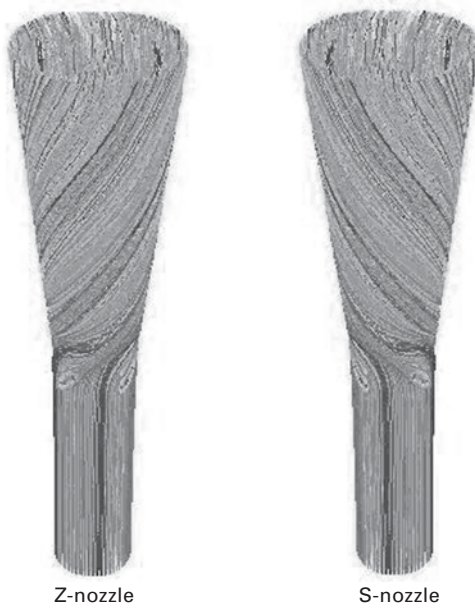

7.18 Typical airflow in Z- and S-nozzles (courtesy of A. Patnaik, PhD thesis).

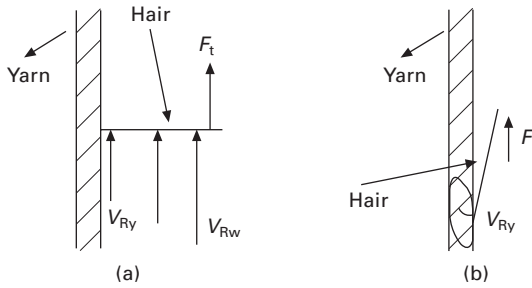

7.19 Drag forces acting on a hair: (a) transverse; (b) longitudinal (courtesy of A. Patnaik, PhD thesis).

Table 7.2 Hairiness values of ring and nozzle-ring cotton yarns (30 tex) with nozzles having air inlets of different axial angles

Sample code	Number of hairs/100 m length of yarn						
	N1	N2	N3	N4	N6	N8	S3
Control	2810	275	84	43	10	1	138
Z40-2.2	2642	253	43	17	5	0	65
Z50-2.2	2612	269	48	17	7	0	72
Z60-2.2	2729	259	55	23	7	0	85

### *Ring spinning systems with modified spinning triangle*

Compact spinning and solo spinning systems are being developed with the aim of modifying the geometry of the spinning triangle to improve the structure of ring yarns by effectively binding the surface fibres into the body of the yarn, hence reducing yarn hairiness.

#### Compact spinning

In the case of compact spinning, the width of the fibre strand emerging from the front roller nip is condensed when leaving the spinning triangle with a small base at the front roller nip, virtually eliminating edge fibres.

#### Solo spinning

In solo spinning, the drafted fibre strand is divided into sub-strands that form the spinning triangles. At the apex of the triangle(s), the sub-strands are twisted together, similar to the plying of several yarns. The edge fibres in each sub-strand are trapped within and between strands. Solo spinning is primarily being developed to make single woollen yarns suitable for use as warps without plying. The solo spinning attachment can be fitted onto

existing ring-spinning machines; it consists of a pair of solo spun rollers held in a bracket, which is clipped onto the front of the drafting arm. Each roller is positioned immediately below the top front draft roller, where it interacts with the emerging drafted fibre strand before twist insertion. The surface of the solo spun-roller is made up of lands and in between them are slots that are offset.

## 7.5 Future trends

The problems associated with air-jet spinning using two nozzles have been harsh and rigid yarns, difficulty in spinning cotton fibres and poor yarn strength. The method of air-jet spinning with a single nozzle developed by Murata can produce yarn at 400 m/min. The problem of generating more wrapper fibres during spinning and consequently improving the yarn strength has been tackled to a major extent by this new technology. The strength of yarn produced from this 'air-vortex spinning' technology is considerably higher than that from the previous method but a little lower than that of ring yarns. The air-vortex yarn surface looks like a ring-spun yarn. Air-vortex spinning has the potential to replace ring spinning in the medium count range (10–60 Ne). Rotor spinning will expand its market share for yarns in the range 6–20 Ne. For the production of fine and very fine yarns (60–160 Ne), especially from cotton fibres, ring spinning will continue to dominate the market.

## 7.6 References and bibliography

- L. Chang and X. Wang, 'Comparing the hairiness of Solo spun and ring spun worsted yarns', *Textile Res. J.*, 73(7), 2003, 640–644.
- K. Z. Chen, C. Z. Huang, S. X. Chen and N. Pan, 'Developing a new drafting system for ring spinning machines', *Textile Res. J.*, 70(2), 2000, 154–160.
- Marzoli (2009), <http://www.marzoli.it>
- R. S. Rengasamy, V. K. Kothari, A. Patnaik and H. Puneekar, 'Airflow simulation in nozzle for hairiness reduction of ring spun yarns: Part I: Influence of airflow direction, nozzle distance, and air pressure', *J. Textile Inst.*, 97(1), 2006, 89–96.
- R. S. Rengasamy, A. Patnaik and R. Anandjiwala, 'Simulation of airflow in nozzle-ring spinning using computational fluid dynamics: Study on reduction in yarn hairiness and the role of air drag forces and angle of impact of air current', *Textile Res. J.*, 78(5) 2008, 412–420.
- Rieter (2009), <http://www.rieter.com>
- Schlafhorst (2009), [www.schlafhorst.oerlikontextile.com](http://www.schlafhorst.oerlikontextile.com)
- X. Wang and M. Miao, 'Reducing yarn hairiness with an air-jet attachment during winding', *Textile Res. J.*, 67(7), 1997, 481–485.

---

P. R. LAMB and X. WANG, Deakin University, Australia

**Abstract:** This chapter describes two modifications made to the conventional ring spinning technology, termed Sirospun™ and Solospun™, which were primarily aimed at significantly reducing the production cost of fabrics. Both were invented at CSIRO in Australia, hence the name ‘Siro’ spinning. The properties of Sirospun and Solospun yarns are different from those of conventional ring-spun yarns and this has opened new market opportunities.

**Key words:** ring-spinning, Sirospun, Solospun, weavable singles, CSIRO.

## 8.1 Introduction

This chapter initially explains, as a background, the main problem of ring spinning. The basic differences between short-staple and long-staple ring spinning are then described as they influence the production cost of yarns made for weaving (i.e. weaving yarns). The principles and mechanical features of firstly Siro spinning and secondly Solo spinning are explained. The resultant yarn properties are discussed, including how they differ from the two-fold ring-spun yarns they are intended to replace, the advantages and disadvantages of these yarns, and their impact on woven fabrics. A brief outline is given of the linkage of these two processes to the development of splicing and coloured contaminant detection, and their similarity to compact spinning is also considered.

## 8.2 Background

The ring and traveller system is a remarkable self-compensating mechanism for inserting twist into a strand of fibres and as such has survived for several hundred years. However, this method of twist insertion is very expensive because of its low production speed. Ring spinning is more expensive than the total cost of all the prior processes up to the spinning frame.

As is explained in Chapter 1, in order to insert *real* twist during ring spinning the whole package (bobbin) must rotate inside the yarn balloon once for every turn of twist inserted. Rotation of the package cannot be avoided without changing to an open-end system in which there is a break between the fibre supply and twist insertion point. A very fine yarn of, say, 10 tex (10 g/km) may have around 1000 turns/m. If the spindle rotates at

10,000 turns/min, the production speed would be 10 m/min or 0.6 km/hour or 36 kg/spindle/year, assuming 6000 hours of running time per year or 24 hours per day, six days per week at 80% efficiency. A similar calculation for a 20 tex yarn yields approximately 100 kg/spindle/year. The important disadvantage, then, is that a single ring spindle is a very low production unit. Hence a large number of spindles are needed. A typical mill would have at least 10,000 and in a few cases as many as 100,000 spindles. The cost per spindle and the associated labour, energy and capital costs are therefore substantial. To reduce the costs of spinning, either the production per spindle must be increased or the associated costs reduced.

The basic features of short-staple (cotton) and long-staple (wool) ring spinning are similar, but there are important differences which influence the economics of both the yarn and the fabric production associated with each. In particular, the differences of length, fineness and the nature of the fibres spun merit consideration. Cotton, for example, is much finer and shorter than wool; it has a higher tenacity but lower extensibility. The scale of the drafting system geometry is therefore related to these fibre parameters. The sizes of the rings and bobbins are much smaller for cotton fibres because the yarns are, on average, finer. The shapes of the rings and travellers are also different for the two fibre types. This is because the cotton traveller is designed to crush loose fibres, enabling the wax on the cotton fibre to lubricate the sliding action of the traveller around the ring. For wool, lubricating oil is wicked onto the ring and the traveller slides on this lubricating film. The smaller rings and travellers enable short-staple ring-spinning speeds to be approximately twice those for long-staple.

The most significant difference between the spinning processes is the method used to achieve the fundamental requirement that a yarn for weaving must be able to survive the cyclic stresses and abrasion of the weaving process. Rubbing a finger and thumb forwards and backwards over a lightly gripped singles yarn will cause loose fibres to be rolled into fibre balls and the yarn will eventually break. The same sort of abrasion happens to the warp yarns on the loom. This leads to weak places, jamming in the reed and to neighbouring yarns becoming entangled, causing increased breakage during weaving. The result is increased labour cost for repairing yarn breaks, lower weaving efficiency because of machine stoppages, and lower quality fabrics owing to faults including those caused by the many yarn repairs.

To minimise the effect of abrasion, the standard practice has been to use two-fold yarns for weaving wool-based fabrics, and to apply a size coating on singles yarns for weaving cotton type cloths. Thus, after spinning, singles cotton yarns have a starch (size) applied to them, enabling them to survive the abrasiveness of the shedding action during weaving. The starch size is a glue that is soluble in warm water and therefore after weaving can be washed out of the fabric. For wool yarns the alternative method of using two-fold

yarns to avoid abrasive failure involves taking pairs of spun yarns (i.e. two singles) and twisting them together, usually in the opposite twist direction to the single's twist direction.

The methods outlined below avoid the need for two-folding by greatly improving the binding-in of surface fibres within what is still essentially a singles yarn having unidirectional twist. In doing this they also reduce hairiness, which contributes to reduced entanglement between neighbouring yarns during weaving, but the more important effect is to bind fibres so that there are not long lengths which can become entangled and to prevent the rubbing-up of loose fibres by the oscillating reed.

### 8.3 Sirospun

Sirospun can be seen as a pseudo-two-fold yarn in which the two components are untwisted strands rather than twisted singles yarns. To some extent it built on the concept of self-twist spinning, also invented at CSIRO (Henshaw, 1969). In self-twist spinning two drafted strands have cyclic false twist inserted by a set of oscillating rollers. One strand is made to follow a longer path so that when the two strands are brought together their twist is out of phase. In trying to untwist, the two strands twist about each other, capturing oscillating twist in each strand. Production speeds to 200 m/min were possible and the yarns could be used for knitting. However, to be weavable the yarn had to undergo a real twisting in a separate twisting step (ring twisting or two-for-one twisting) as with normal two-fold yarn production.

#### 8.3.1 Long-staple Sirospun

The aim was to achieve a weavable worsted yarn by capturing strand twist during twist insertion on the ring-spinning frame and to avoid the need for a subsequent twisting. The initial steps were taken at CSIRO in the mid-1970s (Plate and Lappage, 1980). Two strands were fed side-by-side through the drafting system and, on leaving the front rollers, passed through a further pair of rollers that intermittently blocked the twist from propagating up to the nip line (Fig. 8.1). The two strands were brought together by the twist to form a large, long spinning triangle (the 'vee'). The twist-blocking rollers caused the twist running into the two strand arms to increase and decrease. This intermittent twist becomes trapped in the yarn below the convergence point, which is held fixed by a guide, as alternating twist of the strands relative to the rotating point of contact (i.e. the mean folding twist). The alternating twist enables surface fibres to be trapped between the two strands. Plate and Lappage (1980) showed that the amount of trapping is proportional only to the alternating strand twist and is independent of the two-fold twist. An alternative method by Lappage (1973) achieved a

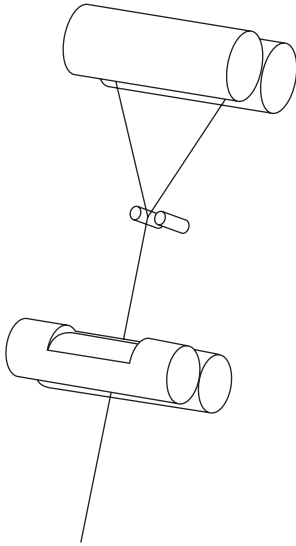

8.1 Schematic of two-strand spinning system with intermittent twist blocking roller.

similar result by vertically oscillating the convergence guide without the twist-blocking rollers.

Even though twist is observed in the strands during Sirospun spinning, if it is constant then none of it is trapped in the yarn. Real (net) twist cannot be introduced, only alternating twist. This is illustrated in the model of Fig. 8.2 (following Plate and Lappage, 1982) in which the two singles strands are represented by long rubber cylinders. One of the untwisted cylinders has a black line along its length (Fig. 8.2(a)), representing a surface fibre. If real twist is inserted then the surface fibre traces a helical path (Fig. 8.2(b)) and every turn of singles twist leads to a trapping point of the fibre after two-folding (Fig. 8.2(c)). If the strand twist remains constant then there is no real (alternating) twist of the strands relative to each other. A fibre that starts on the surface always remains on the surface (Fig. 8.2(d)). This is the basic reason why ordinary singles yarns (or Sirospun yarns at small strand spacing) are not weavable. In such yarns there is a small amount of fibre migration, due to varying spinning tensions and movement of the delivery positions of fibres, but overall many surface fibres are poorly trapped and will be easily rubbed up along the yarn during weaving. Constant strand twist above the convergence point just leads to fibres maintaining their relative positions in the two strand yarn; removal of the two-fold twist will leave two untwisted strands. When two strands are held at both ends insertion of real twist is not possible and only varying twist can enable trapping. There are numerous publications where it is stated or assumed that increasing the

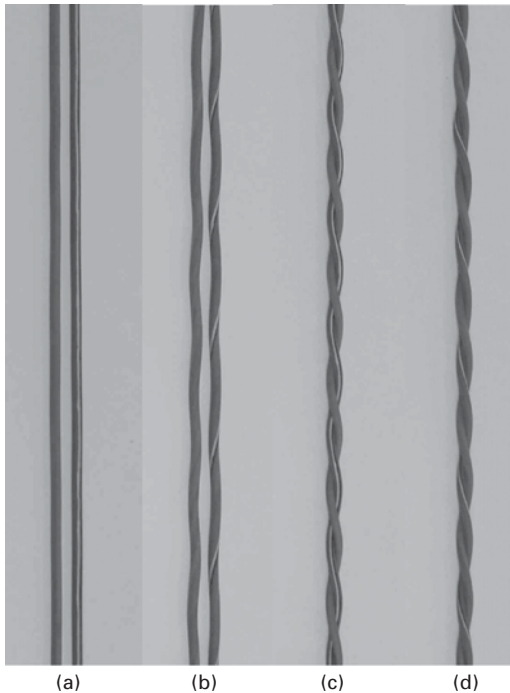

8.2 Model yarn showing (a) untwisted strands, (b) twisted singles, (c) two-fold and (d) two-fold of untwisted singles.

observed level of strand twist will lead to better fibre trapping or a stronger yarn. This is not correct; fibre trapping will only be increased if more strand twist leads to increased variation in the relative twist of the two strands as they are brought together at the convergence point.

In the initial attempt at producing weavable singles yarn it was found that, although the twist-blocking roller gave weavable yarns, the abrasion resistance of the yarns was still adequate without the twist-blocking roller. It was discovered that the natural variation in the number of fibres in the strands caused sufficient twist variation for surface fibre trapping. A second mechanism also occurred (Plate, 1983a), namely fibre ends being caught in the vee, i.e. free fibre ends can have more or less twist than the strand. The binding mechanisms increase with strand spacing, so it has been observed that abrasion resistance improves and hairiness decreases with increasing strand spacing. However, above a certain spacing it is found that the number of spinning breaks rapidly increases. This is because the strand arms start to draft. Under typical conditions of twist and tension, only about half of the final twist propagates up into each strand. For normal levels of twist for weaving yarns, this is borderline for preventing drafting. However, if the strand arms are short, significant numbers of fibres are gripped both at

the roller nip and below the convergence point, which prevents drafting. Consequently, spinning performance tends to deteriorate rapidly as the strand length approaches the mean fibre length. This explains why the recommended metric twist factor for Sirospun wool yarns is 120 to 130 and that spinning performance improves significantly with long fibre length.

If mean strand properties do not change with length (or time) then the size of the spinning triangle should increase with strand spacing but the geometry (convergence angle) and twist level should remain constant. In fact, it has been observed that the number of turns per metre of twist in the strand arms decreases slightly with increasing strand spacing while the convergence angle (the angle between the strands) stays almost constant (Miao *et al.*, 1993). Fluctuations in strand linear density will cause changes in the local twist of each strand and this variable twist can be trapped. Such 'strand twist' can be observed but the methods are laborious (Johnson and Young, 1985). The better test of fibre trapping is the degree to which yarn abrasion resistance is improved.

It is possible for one strand arm to break and spinning to continue. Such a half-weight strand would cause an extremely serious fabric fault. To prevent this, a break-out device was introduced (Fig. 8.3). The break-out device became the core patented part of the Sirospun process. When one strand breaks the pair of guides are toppled off their seat and the yarn now has to loop round the pins. Twist is prevented from flowing up from the rotating bobbin causing both strands to be broken.



8.3 Sirospun break-out device.

The changes needed to the ring spinning frame to produce Sirospun yarns are thus a double creel (for twice the number of roving packages), a double set of roving guides, a wider middle (apron) roller recess, modified front-zone condensers (if used), and the break-out device (Fig. 8.4). The yarn count per spindle is doubled and the amount of twist inserted is usually the same as would be inserted in the two-folding operation (a metric twist factor of 120 to 130) which is similar in turns per metre to that put in the singles yarn. The recommendation is still to have the same total number of fibres in the yarn cross-section as the equivalent two-fold yarn (e.g. for wool, at least  $2 \times 35 = 70$ , given the accepted spinning limit of 35 fibres in the yarn). This twist level and number of fibres are needed to ensure good spinning performance by avoiding drafting of the strand arms. Studies (Plate and Feehan, 1983; Plate, 1983a) have shown that the optimum strand spacing is a balance between improved abrasion properties and poorer evenness and spinning performance. It was found that yarn abrasion resistance increases linearly with strand spacing, hairiness drops rapidly at first, then slowly, and yarn evenness, tenacity and elongation improve at first, then plateau and later decrease. The standard strand-spacing of 14 mm has been adopted for worsted spinning (Plate, 1983a).

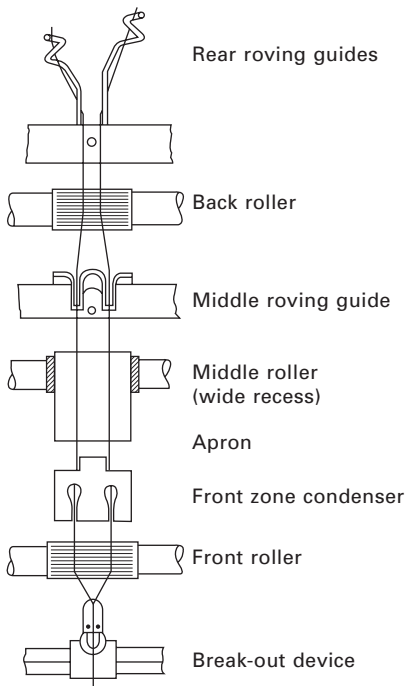

8.4 Sirospun components.

Extensive trials comparing Sirospun yarns with equivalent two-fold yarns have shown that Sirospun yarns have higher tenacity and elongation and lower hairiness. They should be expected to have the same evenness because both yarns are made up of two strands that are identically drafted. However, on average they have marginally poorer evenness, possibly due to correlations between the drafting of strands through the same drafting zone and due to occasional strand-arm drafting. Studies (Plate, 1983a, 1983b) of worsted yarns show that Sirospun yarns are not quite as abrasion resistant as the equivalent two-fold and more likely to fail on the loom under extreme conditions, such as in the selvedge. Allen and Plate (1985) observed that Sirospun yarns have more thin places than two-fold yarns produced from the same material and observed that extreme thin places are associated with higher spinning tension. This is consistent with the cause being strand-arm drafting.

It is often thought that Sirospun is really a two-fold yarn in which real twist is trapped in the strands. This is impossible; real twist cannot be inserted when both ends are held fixed. It is much better to think of Sirospun as a singles yarn with improved binding of the surface fibres. It still has the unidirectional twist and will give rise to the same spirality as a singles yarn. As singles, Sirospun yarns are leaner than the equivalent two-fold yarns. This is a potential cause of more visible streakiness in plain-weave piece-dyed fabrics where the uniform colour and simple pattern provide the least hiding of the yarn irregularity that is always present.

With Siro spinning the cost of the spinning stage is roughly halved, because production per spindle is doubled and two-folding is eliminated. One drawback is that winding and clearing are carried out on the final yarn rather than the singles. This means that the joins (splices) must survive weaving unaided by a good (unspliced) yarn. The performance of splices in weaving is so critical that Sirospun could not gain wide commercial adoption until improved wool splicing (the Thermosplicer™) was available.

### 8.3.2 Short-staple Sirospun

Extensive research (for example, Cheng and Sun, 1998; Sun and Cheng, 2000) has shown very similar results for cotton Sirospun as for worsted Sirospun. The wider the strand spacing the better the yarn properties were, in terms of tenacity, hairiness, abrasion resistance and trapped strand twist. The optimum strand spacing for combed cotton is about 9 mm. This smaller spacing compared to that for wool reflects the shorter cotton fibre length and the need to avoid drafting of the strand arms. It was also found that although Sirospun cotton yarn was less hairy and more extensible than conventional two-ply yarn, it was inferior in evenness and imperfections. An interesting side-effect of the reduced yarn hairiness, also applicable to compact yarns,

is that there is less ring lubrication from crushed fibres and consequently specially treated travellers and the use of as light a traveller as possible are recommended.

### 8.3.3 Alternatives to Sirospun

Two-strand spinning can, of course, be carried out without the break-out device and the spinner can rely on single strand yarn being detected and removed by the clearer in winding. The problem here is that the clearer will not necessarily detect a slow disappearance of one strand or may not remove further lengths of single strand when winding resumes after a cut. If such a half-weight yarn survives into the woven fabric it is such a serious fault that the entire length of fabric may lose its value.

Enhanced two-strand spinning has also been tried in which the twist in the strands is alternatively perturbed in one arm then the other (Norman and Wang, 2001). While yarn hairiness and abrasion resistance were improved by the addition of a roller with phased recesses, the tensile and evenness of the yarns deteriorated.

Two quite different but related alternatives to Sirospun that have been developed are Suessen's PLYfil 2000 system and Murata's Twin Spinner. These machines have double-zone drafting from sliver of parallel strands which are then consolidated in an air-jet and wound side-by-side onto a package at high speed. The pairs of yarns are then up-twisted on a 2-for-1 twister. They are thus analogous to Sirospun, and even more to self-twist spinning of weaving yarns, with the air consolidation leading to fibre trapping in the final yarn, but the twist is inserted on a 2-for-1 rather than a ring-frame. The cost savings do not seem to be as large as for Sirospun because of the capital cost of the new machine, and the high-draft system necessarily leads to slightly less even yarns than when there is a sliver reversal between two smaller drafts (Lamb and Junghani, 1991).

## 8.4 Solospun

Work on producing weavable singles yarns from a single roving continued at CSIRO but the potential methods were considered too expensive to be implemented on a spinning frame. However, scientists at WRONZ, New Zealand, including Lappage *et al.* (1994) who had been a co-inventor of the initial Sirospun method, discovered that just adding an extra zone with a negative draft gave a wool yarn with greatly increased abrasion resistance. Knowing that a new way had been found, but not what it was, led to increased effort at CSIRO which resulted in the process now known as Solospun.

Solospun (Prins *et al.*, 1995, 2001) consists of an additional small roller clipped onto the spinning frame so that it is driven by the bottom roller.

The new roller is slotted with the lands and slots alternating (four times) around the circumference (Fig. 8.5). The effect is to split the roving strand into multiple sub-strands that are continually being altered (Fig. 8.6). In this way the fibre-trapping mechanisms of Sirospun are enhanced. Significant

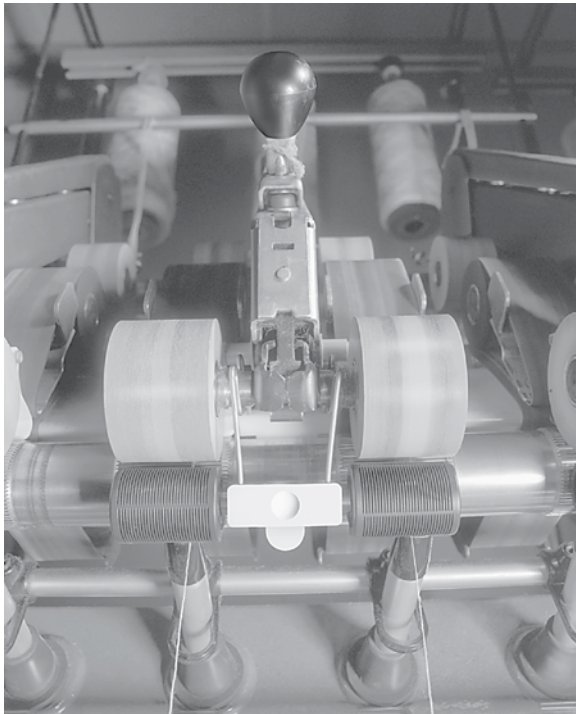

8.5 Solospun slotted roller pair clipped beneath front rollers (reproduced with permission of CSIRO).

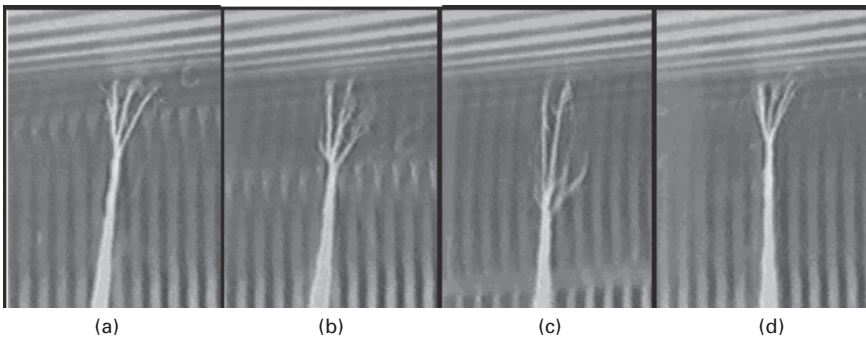

8.6 Production of mini-strands in Solospun (reproduced with permission of CSIRO).

amounts of strand twist can be captured because the number and size of the strands are being almost continuously altered as is the free length into which twist can propagate. The rollers act as intermittent twist blocks, preventing twist from reaching the fibres emerging from the front draft roller nip. The strands are not only spread out along the face of the roller but also vary in the perpendicular direction as they fall into, and are lifted out of, the slots. The action of moving a central strand back and forth between a pair of outer strands can also introduce a form of false-braiding and gives much greater scope for trapping of fibre ends.

The competing methods were evaluated in a joint development between CSIRO, WRONZ and IWS, and the CSIRO method was adopted because of better performance at lower cost. A great advantage of Solospun is that the attachment can be quickly added or removed from existing spinning frames without the need for additional drive shafts or components. Unlike Sirospun, the method operates on a single strand. The spinning performance of the multi-strand yarn with 70 (2  $\times$  35) fibres in the cross-section is much improved relative to singles (35 fibres) or Sirospun. As a result, spinning speeds can be increased, and lower twist factors (down to metric twist factors of 100, and possibly lower when using long fibres) or fewer fibres (down to about 60) can be used. Solospun can thus lead to both higher production and finer yarns than Sirospun and the lower twist can lead to enhanced fabric properties.

Solospun offers the improvements in yarn properties of Sirospun plus more. It does not need the extra creeling and components to handle two strands or the break-out device. The weaving performance of a Solospun yarn has actually been shown to be superior to that of a matched two-fold yarn from the same material even though the yarn evenness was slightly poorer. Solospun was introduced in 1998 and exhibited at ITMA 1999. At the end of 2000 it was reported that more than 60,000 spindles had been installed worldwide with an expectation of 150,000 by 2003 (Anon., 2000). It seems that this figure was probably not reached and it is difficult to establish how many of the supplied rollers are still in operation.

Solospun does not appear to have been made available for cotton. This is believed to relate to the greater difficulty of splitting the finer and more compact cotton strand into sub-strands and to competition from compact yarn spinning when mills are set up to size rather than two-fold yarns to achieve satisfactory weaving performance.

## 8.5 Types of fibres used

Both Sirospun and Solospun were developed for wool and are predominantly used in long staple wool, wool/manmade fibre blends, wool/cashmere or other animal fibres, and 100% manmade fibres, including high-bulk acrylic. For the

standard strand spacing of 14 mm the mean fibre length should preferably be longer than about 60 mm, but longer is better for spinning performance, provided the drafting system can handle the fibre length.

Sirospun lends itself to bicomponent spinning in which the two strands can be of completely different fibres or just of different colours. It appears that virtually all two-colour (marl) yarns are now spun using Sirospun because the strand spacing makes the marl more visible compared with spinning with the strands side by side. This is a reflection of the fact that the binding mechanisms tend to maintain the separate two-strand structure, making the twist more visible and preventing it from being blurred in subsequent abrasion. Sirospun and Solospun both confer a special advantage for blends of wool with continuous filaments. Sirospun with one strand being a continuous single (or multiple) filament has sometimes been referred to as 'Sirofil' but this is not a registered trademark. In Sirospun, if a multi-filament strand is fed in line with one of the two fibre (e.g. wool) strands then improved covering (hiding) of the filament results and a more effective binding of the fibres occurs. (An interesting effect is that feeding the filament down one side rather than the other gives better hiding of the filament, which side depending on the direction of the twist.) A similar improvement is possible with a central strand in Solospun. The binding prevents 'strip-back' in which the wool fibres are rubbed along the filament and into lumps in subsequent processes. The method has been widely adopted for producing stretch weaving yarns using an elastomeric filament (e.g. Lycra™). These yarns were the key to making tight-fitting wool-rich stretch jeans or trousers when fashion is required.

Sirospun with a strand spacing of 7 to 9 mm is used for short-staple (cotton and cotton/manmade fibre blends) spinning. Spinning performance benefits from good fibre length and freedom from faults and there are bigger cost savings for finer yarns, so it is mostly used for combed cotton. Solospun is not currently used in short-staple spinning.

## 8.6 Yarn quality and properties achieved

Sirospun and Solospun are primarily directed at replacing two-fold warp yarns in weaving. In comparison with conventional two-fold yarns which they seek to replace, when the yarns are made from the same input material, they have higher tenacity and elongation and lower hairiness but slightly poorer evenness and fault counts. The Sirospun yarns are slightly less abrasion-resistant than the two-fold, but the Solospun yarns can be slightly more abrasion-resistant. However, unlike conventional two-fold yarn, both yarns are modified singles yarns with unidirectional twist. This is part of the reason why they have higher elongation-at-break values. The fibres are in a helical configuration in the double-strand spun yarns, whereas the fibres in a conventional two-fold yarn are more aligned with the two-fold yarn axis,

having had most of their singles twist removed by the two-fold twist. If the double-strand spun yarns are not set by a steaming operation they will have a tendency to snarl, that is twist around themselves when untensioned.

For weaving yarns it is normal to insert a similar number of turns per metre in the two-fold yarn as in the singles (the singles will typically have a metric twist factor of 90 and the two-fold a metric twist factor of 120 to 130). This is necessary for both good abrasion resistance and a structure which can survive the cyclic tensioning on the loom. It has been found that Sirospun yarns need a similar twist factor (around 130); however, the reason is more to do with preventing thin places due to drafting of the strand arms in spinning. Sirospun or Solospun yarns spun at these twist factors are leaner, and have reduced hairiness, than two-fold yarns. This results in less cover, that is the yarns do not have the bulk to hide the interstices in the woven fabric. Consequently, the fabric is visually more streaky, particularly for plain weaves. Solospun yarns can, however, be spun with significantly lower twist factors (down to about 105 if there is a high number of fibres in the yarn cross-section) and this can overcome the streakiness problem.

Conventionally, singles yarns are spun with Z-twist and two-folded with S-twist. Since it is replacing the two-fold yarn the general practice is to spin Sirospun with S-twist. This practice has become blurred with Solospun because it can be simply clipped on and off the existing spinning frame. The crucial requirement for weaving is not to mix yarns with different twist directions and to ensure that all splicers are set for the particular twist direction.

## 8.7 Advantages and limitations

The main advantage of Siro spinning is cost savings. Previously, in order to produce a warp yarn for worsted weaving it was necessary to spin two half-weight yarns, wind them onto larger packages and then insert two-fold twist using either a ring twisting frame or a two-for-one twister. Now, it is possible to more than double the production of the ring-spinning frame and eliminate the two-fold twisting step. The net effect is to reduce yarn production costs to some 30% to 40% of that for conventional two-fold yarns.

The major disadvantage of Siro spinning is that good spinning performance does not guarantee good weaving performance. In two-fold yarn production it can be generally stated that if singles yarn spinning is satisfactory then weaving performance of the two-folded yarn will be satisfactory. This is not the case with Sirospun and even more so with Solospun and has led to some unhappy early experiences by mills.

Sirospun does not allow the use of a cheaper raw material, e.g. a coarser fibre, than would be used in the equivalent two-fold yarn. The general advice is that the same roving must be suitable for the commercial spinning of singles yarn from one strand (Allen and Plate, 1985). Some mills have

used a longer, coarser fibre and produced yarns with only 60 fibres in the cross-section. Spinning performance was good but weaving performance was unacceptable.

Solospun can actually allow a slightly cheaper raw material. It can give acceptable spinning performance down to about 50 fibres in the cross-section but, at normal twist levels, weaving performance appears to worsen rapidly for less than about 60 fibres in the cross-section. Solospun can also allow lower twist levels but not both lower twist and fewer fibres together. The general guidelines are to keep twist levels and number of fibres in the cross-section higher when using shorter fibres, but allow either lower twist *or* fewer fibres when using longer fibres. Lower twist will give higher production and a softer, fuller yarn and fabric, while fewer fibres gives inferior yarn and fabric but can allow a significantly cheaper fibre to be used.

The components of two-fold yarns are wound and cleared as singles, i.e. prior to conventional two-fold twisting, so any joints made in the singles yarn are supported by a second (unmended) yarn in the two-fold yarn that has to survive warping and weaving. The clearer settings for Siro yarns are necessarily different from those for the singles because fault categories are in proportion to the mean thickness of the yarn and the inherent variation due to varying numbers of fibres in the cross-section will be reduced. Therefore, finer (in terms of percentage) clearer settings are appropriate but the level used will depend on winder efficiency and fabric quality considerations. However, the quality of the knot or splice must be extremely high as it must be able to survive weaving unaided. For wool, hot air splicing (such as the Thermosplicer™ from Schlafhorst/Oerlikon) is strongly recommended.

There can be considerable loss of fibre (up to 5%) in Sirospun if front zone condensers are not used (Plate, 1983a). Appropriate front zone condensers can reduce this to 0.5%. Some loss of fibre can also be expected with Solospun but actual figures do not seem to have been published. The occasional loss of fibre is probably a contributing factor to the higher number of thin places in Sirospun yarns registered by the Uster evenness tester.

Conventional two-fold, Sirospun and Solospun yarns all appear to benefit from a warp lubricant, or waxing. These reduce yarn abrasion and stitching faults due to the entanglement of neighbouring yarns.

For Sirospun, the break-out device must be positioned correctly so that random fluctuations in the strands do not cause the device to fall over. It has also been found that some synthetic fibre blends, or the use of a multi-filament core, can allow the yarn to continue running even when one strand has broken. Another disadvantage of Sirospun, which is overcome by Solospun, is that when one roving breaks or finishes then the other roving continues to be carried through drafting and is lost as fly or can lead to roller lapping.

For Solospun, an inherent problem is that good yarn spinning can still occur even if the attachment is not working (e.g. the slotted roller is not

rotating or is damaged). Thus yarns with poor abrasion resistance can get through to the fabric. Having several such yarns could significantly degrade weaving performance and fabric appearance. Technically, this can now be detected in winding using sensors that monitor yarn hairiness and, if linked winding is used, there is the potential for locating which spindles on the spinning frame are faulty.

Solospun can also be used to produce singles weft yarns. The yarns will not only be less hairy off the spinning frame than conventional singles, but they will also develop less hairiness in subsequent winding and unwinding.

Many knitting yarns are also two-folded but only about 55% of the number of turns per metre is inserted (the singles will typically have a metric twist factor of 70 to 80 and the two-fold a twist factor of 50 to 60). This amount of twist is just enough to make a torque-balanced yarn that has no tendency to twist or snarl when tension is released. Solospun is not appropriate for producing such yarns because the structure has unidirectional twist and is not torque-balanced. However, many yarns are also knitted as singles. If the twist level is not too low and the number of fibres in the cross-section is large, then Solospun will give acceptable spinning performance and a cleaner yarn that will rub up less in subsequent processing and have higher elongation. Such yarns also give a marginal improvement in pilling performance.

## 8.8 Applications

Sirospun and Solospun are just a refinement to ring spinning that are used almost exclusively in the production of weaving yarns, although Solospun can be used in knitwear. As the first process on the market to replace two-fold yarns, Sirospun offered huge reductions in the total cost of woven fabrics. It happened to coincide with, and probably accelerated, a move to lighter weight fabrics. The International Wool Secretariat (IWS) introduced a Cool Wool marketing programme for lightweight trans-seasonal wool fabrics, particularly using plain weaves. A significant proportion of the world's worsted spinning installations were converted and it has been estimated by ABARE (Australian Bureau of Agricultural and Resource Economics) that the benefit of Sirospun to the industry was over AUS\$8 billion by 1992 (Johnston *et al.*, 1992). The information is not readily available on how widespread the current use of Sirospun is and to what extent it has been replaced by Solospun. It definitely has an ongoing market in marl yarns, bicomponent spinning and stretch fabrics.

There was an initial belief that the unidirectional twist of Sirospun yarns would necessarily lead to stiffer fabrics than those made from two-fold yarns. In general, this turned out not to be true. The reason appears to lie in the fact that a significant component of fabric stiffness is determined by the interaction between yarns rather than the stiffness of individual yarns.

After fabric finishing, the leaner and more compact weavable singles yarns interact less when the fabric is bent. In comparisons with fabrics made from conventional two-fold yarns, fabrics woven from Sirospun or Solospun yarns have consistently outperformed, or at least equalled, the conventional fabrics in terms of measured stiffness and assessed handle. Moreover, Solospun yarns can be spun with lower twist factors but similar weaving performance, which has enabled even softer fabrics (Prins *et al.*, 2001).

The main product areas for both worsted and cotton weavable singles yarns are men's wear and ladies' outerwear. Very fine cotton yarns (down to 7.1 tex  $\text{N} \ 2$  or Nm 140/2) have been used for high quality shirts and light gabardine textiles (Friederich, 1991). Solospun has been used with long, fine wool to produce luxurious, soft shirts but the wool or fabric must be adequately shrink-proofed for such applications.

There are several variants of Sirospun that allow new or improved products. One is bi-component spinning with one strand being a soluble PVA filament which is then washed out of the fabric to give an ultra-fine yarn and fabric. A second variant developed in China and named 'embedded composite spinning' (Wei-Lin *et al.*, 2009) is multi-strand spinning which supports shorter or lower strength fibres. The two supporting strands for the two central short fibre strands can be filaments or even yarns. For example, fine cotton yarns have been used to spin a balanced cotton/ramie blend yarn of exceptional quality.

## 8.9 The development of ancillary processes

A key problem with Sirospun is the need for joins in the two-fold yarn which would survive weaving. Garnsworthy and Plate (1982) observed that knots can slip apart under the cyclic tension encountered on the loom, and that there are different versions of what had previously been considered the same knot depending on the twist of the yarn relative to the twist direction of the component overhand knots. The work of Garnsworthy (1981, 1984) on improved methods of splicing resulted in a mechanical splicer that removed and reinserted twist after splicing using counter-rotating discs. This became known as the Twinsplicer<sup>TM</sup> marketed by Savio Macchine Tessili S.p.A. However, this splicer was smaller and more easily implemented for cotton than for wool and was only produced for short-staple yarns. Undeterred, Garnsworthy went on to investigate air splicing and attempted to enhance the splaying of the fibre beard using an electric discharge. He found an improvement but then observed that it continued for some time after the discharge was turned off, and subsequently realised that the improvement was due to the heating of the air. This serendipitous discovery resulted in the Thermosplicer<sup>TM</sup> from Schlafhorst/Oerlikon (Garnsworthy, 1984). It is an air-jet splicer that uses hot air. The burst of heat takes the wool/polymer

above its glass transition temperature (because the moisture in the yarn takes time to escape), making it easier for the yarn ends to be opened, for the fibres to be entangled and then set into the spliced configuration. The Thermosplicer was so important for producing splices that could survive weaving that it is unlikely that Sirospun would have been commercially successful without it.

The improvements in splicing encouraged Plate to initiate research at CSIRO to consider removing other small faults from wool yarns, notably coloured faults from residual vegetable matter (e.g. from grass seeds and burrs) from yarns. This led to the invention of Siroclear™ by Lamb and Prins (Lamb *et al.*, 1988), the first detector for removing coloured contaminants from yarn which was commercially implemented by Loepfe Brothers Ltd as part of their YarnMaster series of clearers.

The ideal of making a weavable singles yarn, using a single roving, was still a desired objective and it was Lappage, now at WRONZ, and colleagues who came up with a potential method. This stimulated revived efforts at CSIRO that led to the invention of Solospun by Prins, Lamb, Naylor and Tao (1995) which was taken to the market by CSIRO, WRONZ and IWS. In a recent development, Tao *et al.* (2006) have combined the dividing roller of Solospun with a false-twist device to produce softer, low-twist cotton yarns.

## 8.10 Future trends

A different approach to reducing costs was to try to improve spinning performance by making modifications aimed at reducing end-breaks. It was argued that most breaks occurred at the spinning triangle where there was less twist and where the load was not shared equally between the fibres – higher loads being borne by the more highly tensioned outer fibres. Ways of compacting the drafted strand before insertion of twist were therefore developed which can be collectively referred to as ‘compact’ spinning. The added compacting zone uses air to reduce the width of the drafted, but untwisted, fibre stream to almost the same diameter as the yarn.

Compact spinning provides an interesting contrast to Solospun where the strand is first split into multiple sub-strands. Interestingly they both reduce yarn hairiness, increase abrasion resistance and lead to stronger yarns. Direct comparisons between the systems using the same raw material do not yet seem to have been made. However, it appears that the improvements in abrasion resistance from compact spinning are not enough to make the singles yarns weavable, but that the compact yarns are more even and, for this reason at least, stronger. Hence, for cotton weaving yarns which are to be sized, compact yarns appear to offer a clear quality advantage. For worsted weaving yarns it appears that compact yarns are not suitable as weavable singles. However, one solution has been to combine compact and Sirospun spinning (Brunt,

2004). Sirospun and Solospun have also been combined (Najar *et al.*, 2006) to give even lower hairiness but otherwise similar properties.

It might have been expected that Solospun installations would far exceed Sirospun. Responses from industry suggest that the main reasons why this does not seem to have happened are (1) the improvement in yarn quality over Sirospun is marginal, and the yarns are certainly not as good as compact spun yarns, (2) the cost of Solospun rollers, and (3) variability from spindle to spindle. The last reason is related to difficulties in monitoring performance. Faulty operation or worn parts, giving poor abrasion resistance, can cause serious problems in weaving but have not been readily visible in spinning and have been only marginally detectable in winding in terms of increased hairiness.

The ideal for a future yarn would seem to be to combine the improvements in quality of compact spinning with a big enough reduction in hairiness and improvement in abrasion resistance to make a weavable compact singles yarn. However, the mechanisms of splitting and compacting seem to be mutually incompatible. Alternative directions are to try to extend Solospun into short-staple or knitting yarns. A step in this direction that seems to be underway is to combine a miniature Solospun roller with false-twisting. The method appears to allow cotton yarns of low twist, which are therefore softer, to be produced (Yang *et al.*, 2007).

## 8.11 Sources of further information and advice

For a deeper understanding of Sirospun the reader is referred back to the five-part series of papers by Plate and co-authors. The components can be purchased through the original licensee Zinser, which is now part of the Oerlikon textile group, as shown in their brochures (e.g. <http://www.schlaflhorst.oerlikontextile.com/en/desktopdefault.aspx/tabid-809/>), or other textile part manufacturers. Relatively little information has been published on Solospun but the key paper (Prins, Lamb and Finn, 2001) can be downloaded (<http://www.csiro.au/files/files/pdt6.pdf>). There have been two commercial suppliers for Solospun attachments. Contact either AgResearch in New Zealand (formerly WRONZ) or Australian Wool Innovation (AWI, previously Woolmark, IWS) for current details. A Technical Manual is available from ITEC Innovation Ltd (<http://itecinnovation.com/productDetails.php?id=201>). The part of CSIRO where these ‘Siro spinning’ developments took place has gone through a number of name changes from the original Division of Textile Industry and is now referred to as CSIRO Materials Science and Engineering – Geelong. A book has been published which summarises its first 50 years of successful research (Williams, 1998) and a summary of the spinning developments that enabled the Cool Wool marketing campaign can be accessed via the CSIRO website (at <http://www.csiro.au/resources/LightweightWool.html>).

## 8.12 References

- Allen L A and Plate D E A (1985), 'On the properties of Sirospun yarns', *Proc. 7th Int. Wool Text. Res. Conf.*, Tokyo, Vol. II, 396–407.
- Anon (2000), '60,000 go solo', *Text. Month*, December, 38.
- Brunt N (2004), 'EliTeCompactSet – versatile method of yarn compaction', *Melliand Int.*, 10(1), 24–26.
- Cheng K P S and Sun M N (1998), 'Effect of strand spacing and twist multiplier on cotton Sirospun yarn', *Text. Res. J.*, 68(7), 520–527. doi: 10.1177/004051759806800709
- Friederich T (1991), 'Siro spinning method – a profitable way to manufacture two-ply yarn', *Melliand Textilber.*, 72(5), 319–322, E125.
- Garnsworthy R K G (CSIRO) (1981), 'Splicing yarn', Australian Patent 543623.
- Garnsworthy R K G (CSIRO) (1984), 'Pneumatic splicing of yarns', Australian Patent 566956. (Also US Patent 4,577,458, German Patent 3437199.)
- Garnsworthy R K and Plate D E A (1982), 'Knots – old and new – for the textile industry', Report No. G45, CSIRO Division of Textile Industry, Belmont, Australia.
- Henshaw D E (1969), 'Self-twist yarn', *J. Text. Inst.*, 60(11), 443–451.
- Johnson N A G and Young M D (1985), 'The structure of Sirospun yarns', *Proc. 7th Int. Wool Text. Res. Conf.*, Tokyo, Vol. II, 386–395.
- Johnston B G, Tulpule V, Foster M and Gilmour K (1992), 'Sirospun: The economic Gains from Sirospun technology', ABARE Report 92.5.
- Lamb P R and Junghani L (1991), 'Drafting and evenness of wool yarns produced on the PLYfil, Sirospun and two-fold systems', *J. Text. Inst.*, 82(4), 514–517.
- Lamb P R, Plate D E A, Prins M W, Allen L A, Gore C E, Hageman P, Smith C and Spence D W (1988), 'The removal of coloured contaminants from undyed yarn during winding', *Proc. Text. Inst. World Conf.*, Sydney.
- Lappage J (CSIRO) (1973), 'Method and apparatus for forming yarn', US Patent 3,695,019.
- Lappage J, Johnson N A G and Hartshorn O L R (WRONZ) (1994), 'Improvements to the manufacture of yarn spun on closed-end, high-draft spinning systems', New Zealand Patent 254280. (Also International Publication No. WO94/01604, Australian Patent 673532.)
- Miao M, Cai Z and Zhang Y (1993), 'Influence of machine variables on two-strand yarn spinning geometry', *Text. Res. J.*, 63(2), 116–120. doi: 10.1177/004051759306300208
- Najar S S, Khan Z A and Wang X G (2006), 'The new Solo–Siro spun process for worsted yarns', *J. Text. Inst.*, 97(3), 205–210. doi: 10.1533/joti.2005.0182
- Norman S and Wang X (2001), 'Modified two-strand spinning – Part III: Yarn performance', *Res. J. Text. Apparel*, 5(1), 1–9.
- Plate D E A (1983a), 'An alternative approach to two-fold weaving yarn, Part V: The properties of two-strand yarns', *J. Text. Inst.*, 74(6), 320–328.
- Plate D E A (1983b), 'Abrasion-testing of two-strand yarn', *J. Text. Inst.*, 74(6), 378–381.
- Plate D E A and Feehan J (1983), 'An alternative approach to two-fold weaving yarn, Part IV: Factors affecting strand twist', *J. Text. Inst.*, 74(4), 204–212.
- Plate D E A and Lappage J (1980), 'An alternative approach to two-fold weaving yarn', *Proc. 6th Int. Wool Text. Res. Conf.*, Pretoria, Vol. III, 499.
- Plate D E A and Lappage J (1982), 'An alternative approach to two-fold weaving yarn, Part I: Control of surface fibres', *J. Text. Inst.*, 73(3), 99–106.
- Prins M W, Lamb P R, Naylor G R S and Tao X (CSIRO) (1995), 'Yarn spinning',

- Australian Patent 688423. (Also International Publication No. WO95/14800, US Patent 6012277, etc.)
- Prins M W, Lamb P R and Finn N (2001), 'Solospun – The long staple weavable singles yarn', *Proc. Text. Inst. 81st World Conf.*, Melbourne.
- Sun M N and Cheng K P S (2000), 'Structure and properties of cotton Sirospun yarn', *Text. Res. J.*, 70(3), 261–268. doi: 10.1177/004051750007000314
- Tao X, Xu B and Wong S-K (The Hong Kong Polytechnic University) (2006), 'Method and apparatus for manufacturing a singles ring yarn', US Patent 7,096,655.
- Wei-Lin X, Cai-Ling D, Wei-Gang C, Heng-Xing Y, Xiao-Lin S and Guang Q (Wuhan University of Science and Engineering) (2009). 'Positioning spinning method of embedded system' Chinese Patent 101492843 (A).
- Williams V A (1998), 'From Fleece to Fabric, 1948–1998. Fifty Years of Wool Textile Research', CSIRO Wool Technology, Geelong, Australia.
- Yang K, Tao X M, Xu B G and Lam J (2007), 'Structure and properties of low twist short-staple singles ring spun yarns', *Text. Res. J.*, 77, 675–685.

M. A. M. EL-SAYED and S. H. SANAD, Agricultural Research Centre, Cotton Research Institute, Egypt

**Abstract:** Most of the technical advances in ring spinning have aimed to improve the performance of the existing technology. Compact spinning technology has been gaining much interest since its first commercial introduction at ITMA-99 in Paris and it can best be described as a modification of the basic ring frame and friction spinning technique. The mechanism of compact spinning involves narrowing and decreasing the width of the band of fibres which come out from the drawing apparatus before it is twisted into a yarn, and the elimination of the twisting triangle. This causes the fibre stream in the form of the flat band of fibres to be condensed into a compact fibre stream with increased frictional contact points between the fibres.

**Key words:** compact spinning, spinning triangle, yarn strength, hairiness.

## 9.1 Introduction

In spite of modernisation and rapid technological development in the field of ring spinning, the mechanism of ring-traveller and spindle has remained almost the same until recently. Nevertheless, ring spinning remains the dominant spinning technology. The producers of modern spinning frames have been developing machines with improved construction of different working elements and optimal spinning geometry, with a ring diameter of 36 mm, a tube length of 180 mm and a spindle speed of up to 25,000 rev min<sup>-1</sup>. Most of the serving and transport functions have also been automated. A high level of linking spinning and winding, and even of the winding and twisting technological processes, has been achieved using the elements of computer-assisted automation and control. Besides the conventional functions (spindle speed, delivery speed, productivity, twist, draft, machine efficiency), computer-based systems control and enable the optimisation of spinning conditions (formation of bobbins, position of ring rail, automated doffing and setting of empty tubes, cleaning and oiling of main machine parts). Construction improvements of different working elements of the ring-spinning frame and optimised spinning geometry of the continuous form of fibres (roving or sliver) enable increased productivity and better yarn quality, as well as flexibility and profitability of the process.

Compact spinning has been recognised as a revolution in ring spinning.

This technology is claimed to offer superior quality and better raw material utilisation (Suessen, 2002; Klein, 1987a; McCreight *et al.*, 1997; Kampen, 2000; Klein, 1993).

### 9.1.1 Basic principles of compact spinning

Compact spinning is simply the modification of the conventional ring spinning system at the drafting zone with some additions and modifications to its existing drafting system. The idea of compact or condensed spinning is to minimise the change in the width of fibre strand by applying air suction to condense the fibre stream in the main drafting zone and a substantial reduction (almost elimination) of the spinning triangle. This is achieved using an air-suction system and a perforated surface mounted in the fibre flow line.

### 9.1.2 Yarn formation: compact spinning vs. ring spinning

In ring spinning, the main source of the fibre migration is acknowledged as the tension differences between fibres during the yarn formation. When a thin ribbon-like fibre bundle is transformed into a roughly circular shape by twist insertion, fibres at the edges of the bundle are faced with tension, whereas fibres in the middle are subjected to compression unless there is excessive yarn tension. To release the stress, fibres subjected to tension try to shorten their path length in the yarn while fibres under compression try to lengthen it. As a result of this, fibres leave their perfect helical path and migrate between layers of the yarn (Klein, 1987b). In compact spinning, tension differences between fibres during twist insertion is smaller than those in ring spinning due to the elimination of the spinning triangle. Therefore fibre migration in compact yarns could be expected to be less than that in conventional ring spun yarns.

### 9.1.3 Ring spinning drawbacks; spinning triangle, fibre migration and yarn hairiness

In the ring spinning frame, the fibre bundle follows a path between the drafting system and yarn take-up on the cop. This path involves the drafting arrangement, thread guide, balloon control ring and traveller. These elements are arranged at various angles and distances relative to each other. All these distances, inclinations and angles are referred to as the spinning geometry. The spinning geometry has a significant effect on the end breaks, tension conditions, and generation of fly, yarn hairiness and yarn structure (Klein, 1993). Twist is imparted by the traveller, and goes up as close as possible to the nip line of the front rollers. However, twist never penetrates completely to the nip line. Since the width of the fibre bundle emerging from the

drafting system is many times the diameter of the yarn to be spun, fibres in the bundle have to be diverted inwards and wrapped around each other. Consequently, at the exit from the front rollers there is always a triangular bundle of the fibres without twist, which is called the ‘spinning triangle’ (Klein, 1987a; McCreight *et al.*, 1997). Figure 9.1 shows one such spinning triangle. Most of the end breaks initiate at this weak point because each fibre in the spinning triangle does not contribute to the yarn strength equally during the yarn formation.

Fibres in the centre of the spinning triangle are not subjected to any tension, and thus are bound together without being elongated, while the external fibres have to resist the full force of the balloon tension. Short fibres in the spinning triangle can contribute very little to the strength of the forming yarn (Olbrich, 2000). The length of the spinning triangle is determined by the twist level, drafted ribbon width, spinning tension and spinning geometry. While high yarn twist causes a short spinning triangle, low twist causes a long triangle as shown in Fig. 9.2.

Klein (1987a) has pointed out that a short spinning triangle represents a short weak point and thus fewer end breaks. He also indicates that if the spinning triangle is too short, the deflection of the fibres on the edges has to be very sharp during the binding-in. This is not possible with all fibres. Therefore a very short spinning triangle results in some fibres on the edge not to be integrated into the yarn, resulting in loose fibres or ‘fly’. Other fibres on the edge might be bound-in at one end only, causing hairiness. On

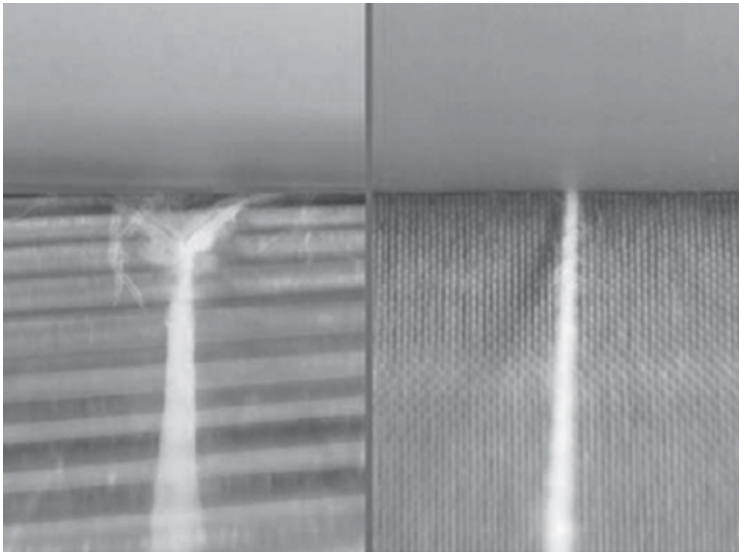

9.1 Spinning triangle in ring spinning vs. compact.

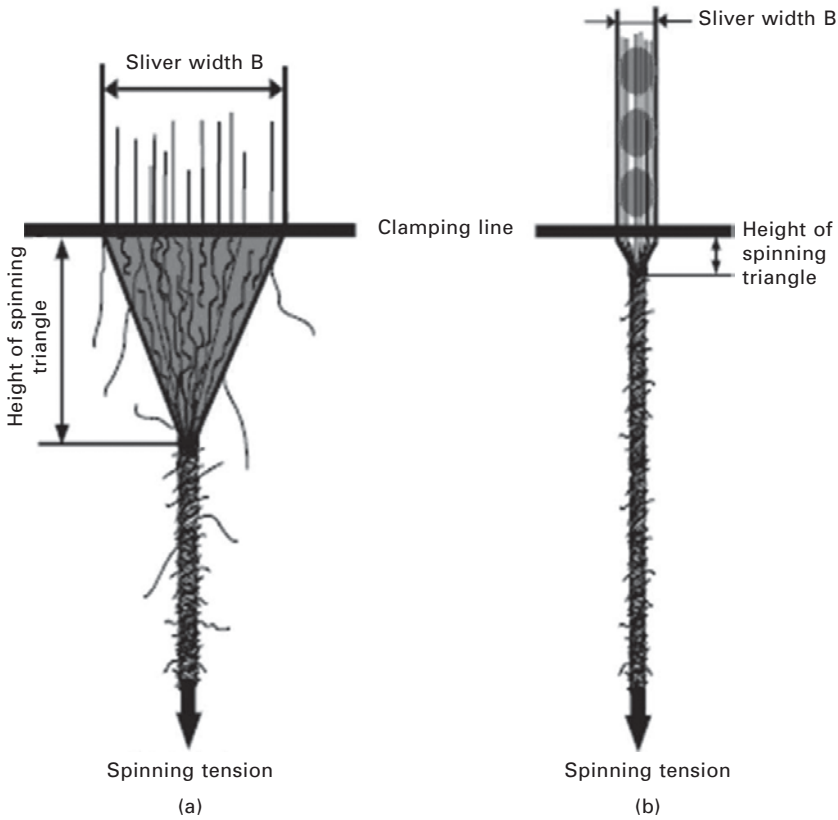

9.2 Spinning tension in (a) conventional ring and (b) compact spinning (Artzt, 2000).

the other hand, a long spinning triangle results in a longer weak point, and thus more end breaks. However, with a long triangle, fibres are better bound into the yarn. This produces a smoother yarn and less fly.

In general, unincorporated fibres in ring spun yarns stand out from the twisted yarn core, and cause hairiness, which is a disturbing factor in subsequent process steps (Kampen, 2000). Compact spinning aims at eliminating the spinning triangle and the above problems associated with it. The following sections present the history of the compact spinning process, the differing techniques employed by various machine manufacturers and the resulting improvement in yarn properties.

### 9.1.4 History of compact spinning

The idea of compact spinning emerged during the attempts made by Rieter under the direction of Dr Ernest Fehrer (Wutthorst, 2000) to adapt a ring

spinning frame for spinning from a sliver feed, delivered to the ring spinning machine in sliver cans. In order to achieve this desire, some modifications on the ring spinning machine were necessary. Dr Fehrer came up with the idea of dividing a drafted sliver onto two spindles by means of suction and compressed air, which can best be described as a modification of the basic ring frame and friction spinning techniques (Fehrer's DrefRing development) (Barella and Manich, 1997). Several trials were run on a modified Rieter ring-spinning machine. The results showed that this method was technically viable, but very expensive due to the large space requirements for the sliver cans and the costly, longer-distance sliver feed. On the other hand, the quality of the produced yarn was surprisingly good even though the draft employed during spinning was very high, and the fibres were fed from the untwisted sliver. A closer study showed that the reason for this superior yarn quality was the condensation of the fibres subsequent to the division of the sliver. This incident led researchers to focus on developing a drafting mechanism with a mechanical/pneumatic fibre condenser unit to obtain excellent yarn parameters in ring spinning. It took many years to operationally reach commercial acceptance.

During that period, it became evident that a range of technical solutions with a series of alternatives could achieve the same effect. Later, other textile machinery makers patented competing technical solutions (Meyer, 2000). With the invention of compact spinning, for the first time a new spinning process was not aimed at exclusively achieving higher production speeds, but at better fibre strength utilisation and yarn quality. Stadler (1995) discussed a number of ways by which the fibres can be condensed. One conventional way is to increase the twist in the roving to an optimum level that will allow better compactness of the fibres during the drafting process, i.e., keeping the fibres together sideways. This method suggests that the roving twist can act as a fibre condenser mainly in the break-draft zone, and partially at the main draft zone. Another approach of condensation is to use mechanical devices, for example a funnel-shaped condenser, located between the aprons and the delivery cylinders. Such an element can in fact add a condensation effect to the fibre flow. The only disadvantage is that because of the frictional drag of the funnel on the fibres, the drafting action is disrupted, leading to a deterioration in yarn evenness and an increased number of imperfections. A third possibility is aerodynamic condensation after the drafting zone, but before the yarn formation.

At ITMA-99 in Paris three textile machinery makers, Rieter of Switzerland, and Suessen and Zinser of Germany, exhibited their compact, or condenser, spinning systems. These systems are somewhat different in each case, but all of them are based on the same principle of using a pneumatic system, or aerodynamic device, to push the staple fibres together and eliminate the spinning triangle, or condensing the fibres to attain a much smaller

spinning triangle than with conventional ring frames as depicted in Fig. 9.3.

This was achieved by adding an extra condensing action between the front roller and twist insertion. Because of this condensing, the width of the fibre bundle is reduced significantly prior to twist insertion, and thus the spinning triangle is nearly eliminated. With the elimination of the spinning triangle, even short fibres are capable of contributing strength, and all the fibres are twisted under the same tension. Moreover, the fibre ends are much more tightly incorporated into the fibre mass (Kampen, 2000; Meyer, 2000; Oven, 1999). Among these companies, only Suessen claimed at ITMA-99, that its technology would be applied virtually to the entire current range of ring spun yarn counts and types.

### 9.1.5 The Suessen compact spinning system

This system consists of an additional ‘drafting zone’, which is mounted on a standard three-roll ring spinning machine (Fig. 9.4). In this drafting zone an air-permeable lattice apron runs over a suction tube. The suction tube is under negative pressure and there is a slot tilted in the direction of fibre movement for each spinning position. After the fibres leave the front roller nip line, they are guided by means of the lattice aprons over the openings of the suction slots where they move sideways and are condensed due to suction air flow. The openings of the suction slots are inclined to the direction of fibre flow. This helps condensing by generating a transverse force on the fibre band during their transport over the slot, causing the fibre band to rotate around its own axis. The lattice apron carries the fibres attached to it up to the delivery nip line. The diameter of the delivery (driven) top roller is slightly bigger than the diameter of the front bottom (driving) roller. This generates a tension in the longitudinal direction during the condensing process. The tension ensures the straightening of curved fibres, and therefore supports the condensing effect of the negative pressure

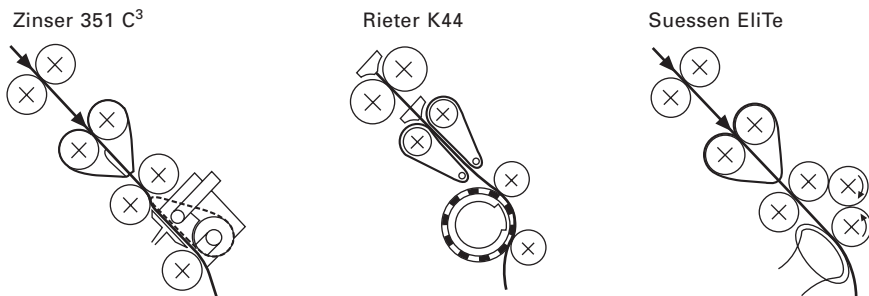

9.3 Different types of compact system.

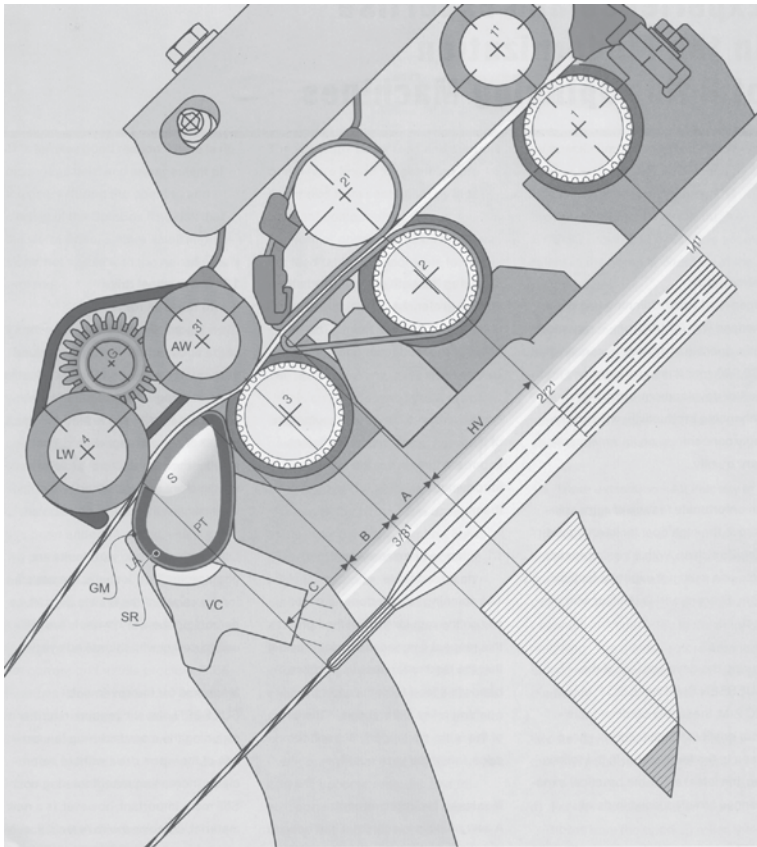

9.4 Drafting system in compact spinning, Suessen EliTe®.

acting on the fibre band in the slot area of the suction tube (Kampen, 2000; Stahlecker, 2000).

#### *Rieter K44 'ComforSpin'®*

The compact spinning concept illustrated in Figs 9.5. and 9.6 is the one represented by the Rieter 'ComforSpin'® process. In this system, aerodynamic forces are used to laterally condense the drafted fibre ribbon after the main drafting zone. As a result, the spinning triangle becomes so small that it is almost eliminated.

As shown in Fig. 9.7, the Rieter K44 ComforSpin machine consists of a three-roller, double-apron drafting system. The exit zone of this system is modified to allow fibre condensation; the exit roller is replaced by a perforated drum (1), within which is a stationary suction unit that is connected to the

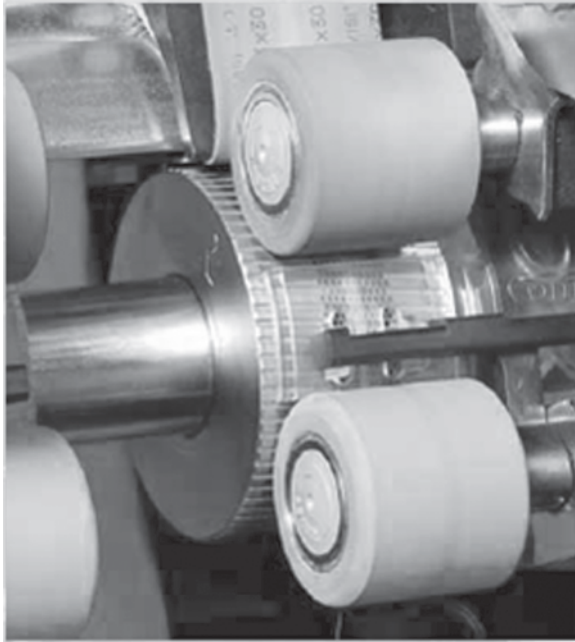

9.5 Rieter K44 ComforSpin® compact system.

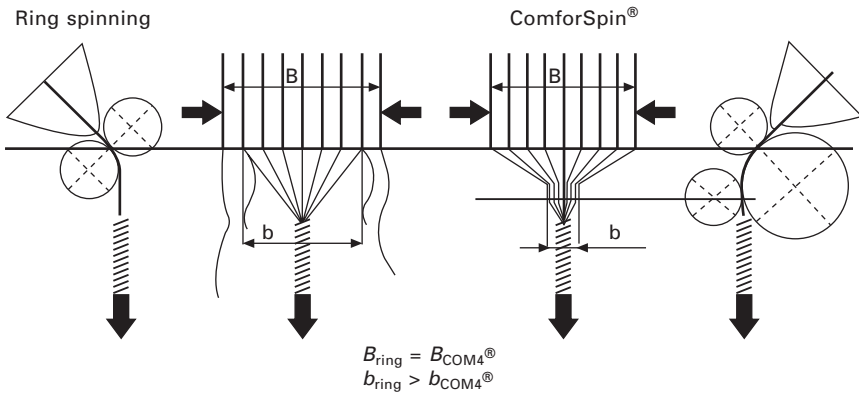

9.6 Rieter K44 ComforSpin® compact system.

machine's central extraction unit (2). The fibres delivered by the exit nip line of the drafting system are held on the surface of the perforated drum, moving at the drum's peripheral speed. Thus, the ComforSpin technology allows aerodynamic parallelisation and condensation of the fibres after the main draft. The spinning triangle is thus reduced to a minimum. The heart of the K44 ComforSpin machine is therefore the compacting zone, which consists

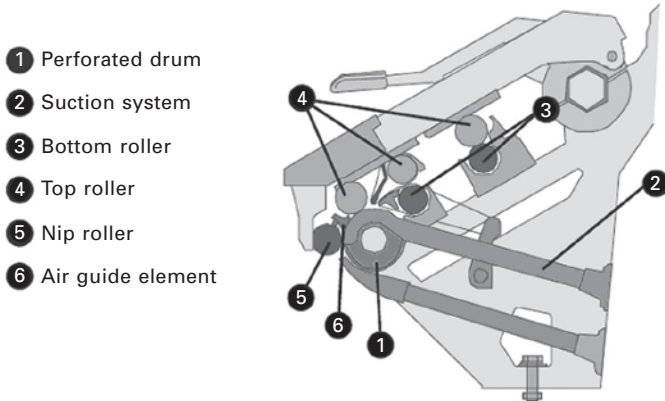

9.7 Rieter K44 ComforSpin<sup>®</sup> compact system.

of the perforated drum, suction insert, and air guide element. The positively driven perforated drum is hard-wearing and resistant to fibre clinging. Inside each drum is an exchangeable stationary suction insert with a specially shaped slot (see Fig. 9.5). This is connected to the machine's suction system. The air current created by the vacuum generated in the perforated drum condenses the fibres after the main draft. The fibres are fully controlled all the way from the nip line after the drafting zone to the spinning triangle. An additional nip roller prevents the twist from being propagated into the condensing zone. The compacting efficiency in the condensing zone is enhanced by a specially designed and patented air guide element (Stadler, 2000). Optimal interaction of the compacting elements ensures good compaction of the fibres. This is claimed to give unique COM4<sup>®</sup> yarn characteristics (Oxenham, 2003a,b; El Mogahzy, 2004).

#### *Suessen EliTe<sup>®</sup> system*

Suessen introduced its EliTe<sup>®</sup> Compact spinning system at ITMA-99, Paris. The Suessen EliTe Compact spinning system is available as modern short-staple spinning systems, called the EliTe CompactSet-S, or retrofitted to existing ring spinning frames, and the EliTe CompactSet-L for existing ring spinning frames in long staple spinning. The EliTe CompactSet is available for almost every ring-spinning machine type made by Rieter, Lakshmi, Shanghai, Zinser, Toyota, Marzoli and many other manufacturers.

The operating principle of the Suessen EliTe spinning system is that on leaving the drafting system the fibres are condensed by an air-permeable lattice apron, which slides over an inclined suction slot (see Fig. 9.8). The system consists of a tubular profile subjected to negative pressure and closely embraced by a lattice apron. The delivery top roller, fitted with rubber cots,

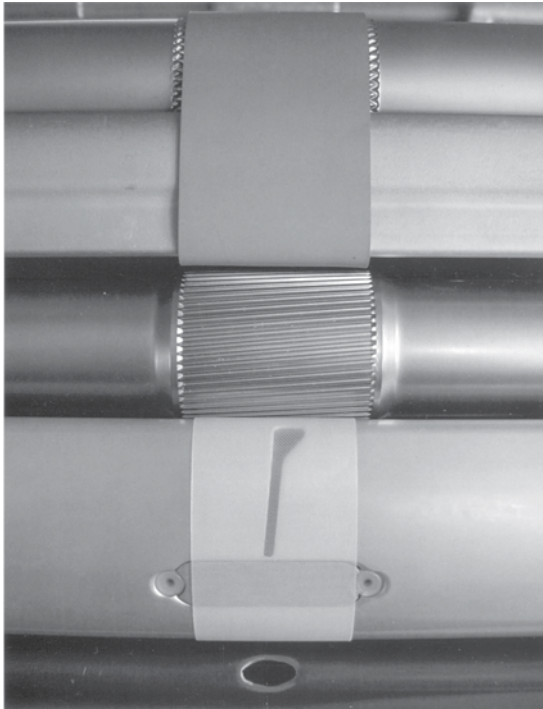

9.8 Lattice apron in Suessen EliTe®.

presses the lattice apron against the hollow profile and drives the apron, at the same time forming the delivery nipping line. The tubular profile has a small slot in the direction of the fibre flow, which commences at the immediate vicinity of the front roller nipping line and ends in the region of the delivery nipping line. This creates an air current through the lattice apron via the slot towards the inside of the profile tube. The air current seizes the fibres after they leave the front roller nipping line and condenses the fibre strand, which is conveyed by the lattice apron over a curved path and transported to the delivery nipping line. As the slot, being under negative pressure, reaches right up to the delivery nipping line, the fibre assembly remains totally compacted. This results in a substantial disappearance of the spinning triangle.

The suction slot can be arranged at an angle to the direction of fibre flow, especially when processing short fibres. This ensures that the fibre ends are well bound into the strand during their transport from the front roller to the delivery nip line. It also creates a cross-directional force during the fibre transport, which in turn causes the fibre assembly to rotate around its own axis so that the fibre ends are closely embedded into the fibre assembly.

*Zinser AIR-COM-TEX 700<sup>®</sup> system*

The Zinser AIR-COM-TEX 700<sup>®</sup> system was introduced at ITMA-99, Paris, and launched the Zinser 351 C<sup>3</sup> shown in Fig. 9.9. It also works on the basis of eliminating the spinning triangle. This system uses a conventional three-cylinder drafting system. The fibres emerging from the drafting system are condensed under suction onto the surface of a perforated belt. The condensed fibre strand undergoes a substantial reduction in width prior to twisting. This reduction in the difference between the width of the fibres emerging from the drafting system and the yarn diameter effectively eliminates the spinning triangle.

The compacting zone can be adapted to the raw materials by the adjustability of the additional feed, because the compacting zone between the two front cylinders can be influenced by a lower speed of the perforated apron with maximum  $-4.0\%$ . For the cotton compact spinning process, from 0 to 4% additional feed is required from a technological point of view. With this spectrum the machine can be optimally set to most fibres. This has a positive influence on the position of the individual fibres, since only unstressed and parallelised fibres can be deflected and compacted.

## 9.2 Types of fibre used

### 9.2.1 Short and long staple spinning

There is an extensive range of commercially available textile fibres which includes natural and man-made fibres. Since the commercial introduction of compact spinning, a large number of studies have been conducted related to the short-staple and long-staple compact spinning techniques, each of

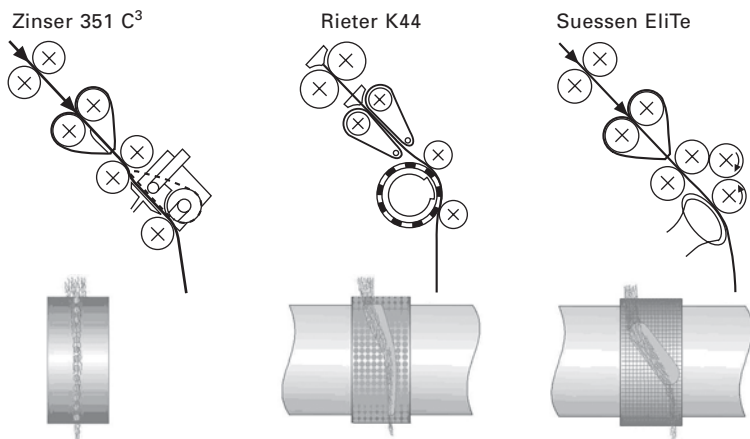

9.9 Fibre path in Zinser 351 C<sup>3</sup><sup>®</sup> and other different systems.

which claims to offer advantages, dramatically increased production speeds, enhanced quality and reduced costs. Various fibre types, such as cotton or cut staple fibres, ‘man-made fibres’ with a wide range of yarn numbers, coarse or fine yarn counts and different fibre structures are spun. The long staple compact spinning permits the spinning of worsted yarns from a given material of superior quality, or the spinning of a certain quality with fibres of a substantially higher added value. Figure 9.12 shows the quality difference between long staple compact-spun yarn and conventional ring-spun yarn of 100% wool.

Figure 9.10 shows the cross-section of the drafting system with the EliTe spinning system for long staple fibres, i.e. wool and man-made fibres. The drafting system is followed by a condensing zone, which consists of the profile tube (1), the lattice apron (2) and the delivery top roller (3). The delivery top roller (3) is driven by the front top roller (5) via a small gear (4). The profile tube (1) is closely embraced by a lattice apron (2) driven

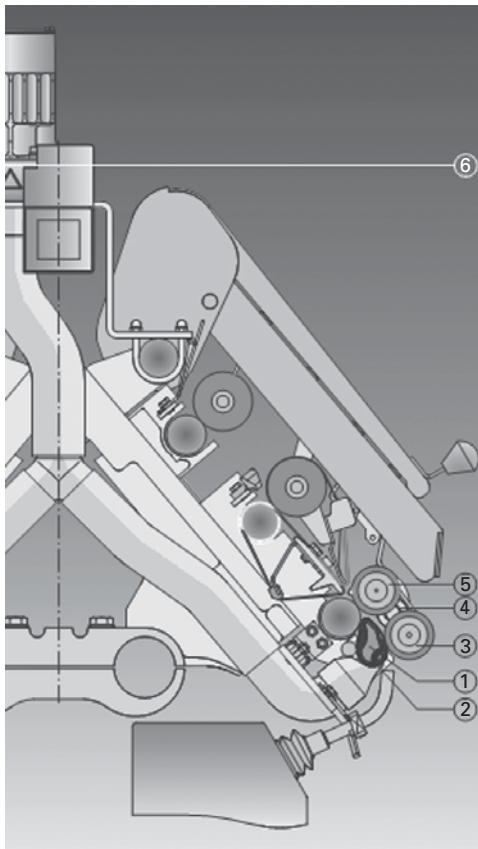

9.10 Cross-section of wool drafting system in Suessen EliTe®.

by the delivery top roller (3). The profile tube is under negative pressure produced by the suction unit (6). The profile tube (1) has an oblique slot extending up to the clamping point between the profile tube and the delivery top roller. The fibres emerging from the drafting system are gripped by the airflow created by the vacuum and the lattice apron and transported towards the oblique edge of the slot and consequently condensed. At the delivery clamping line the fibre strand has achieved its optimum condensation. After the clamping line, twist is imparted to an ideally straightened fibre strand, with individual parallel and optimally condensed fibres without protruding hairs. Consequently, the conditions for yarn production by twisting individual fibres are practically ideal (Anon., 2001).

### 9.3 Yarn quality and properties

When the structure of compact spun yarn is examined under a microscope, it can be seen that the integration of the fibres is high; thus, their contribution to the yarn strength is maximised. If all fibres were fully incorporated in the yarn, the strength and the elongation of the yarn could be increased substantially. In compact spinning, two main factors, the drafting procedure and the yarn formation, affect the structure and the quality of yarns.

#### 9.3.1 Impact of compact spinning on yarn properties

Artzt (1997), Krifa *et al.* (2002), Kadioglu (2001) and Smekal (2001) have compared the properties of compact spun yarns with those of classic ring-spun yarns. These studies showed consistent results in terms of reduced yarn hairiness and the ability to produce yarns of enhanced strength and elongation even with lower twist levels. The compact spinning process produces a new ring-yarn structure which is close to the idealised staple fibre yarn construction as shown in Fig. 9.11. The use of lower twist levels enables increased production speeds to be reached and therefore has positive effects on raw material use, productivity, downstream processing and product appearance (Artzt, 1997).

In compact yarns, wool fibres are uniformly oriented and joined into the yarn right after the end of the drafting arrangement. Therefore, better tenacity, elongation and hairiness properties can be ensured (see Fig. 9.12).

In the weaving stage, a very important issue concerning compact yarn is the improved warping performance due to its increased strength. Normally, when a yarn has higher strength, its performance in warping is ultimately increased, too. It is a well-known fact that even with low twist, compact yarns have up to 20% higher strength than normal ring-spun yarns (see Table 9.1). This fact may divert spinners' attention to reduce twist below the appropriate limit (Iftikhar, 2003).

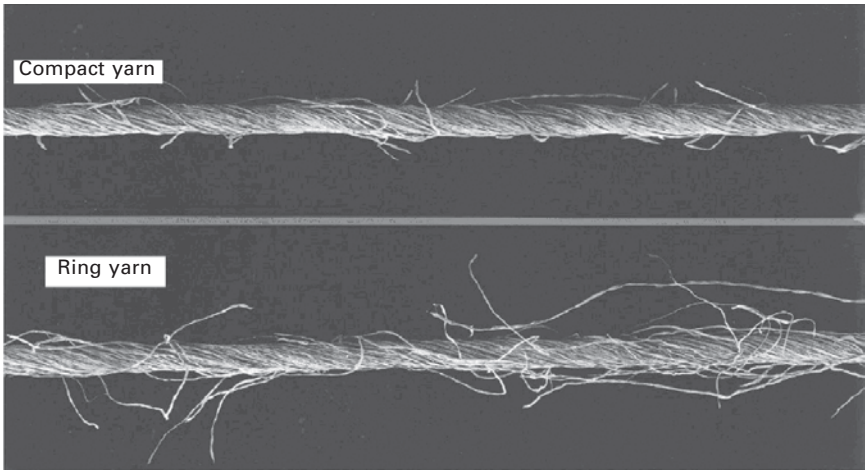

9.11 Yarn structure of compact spinning.

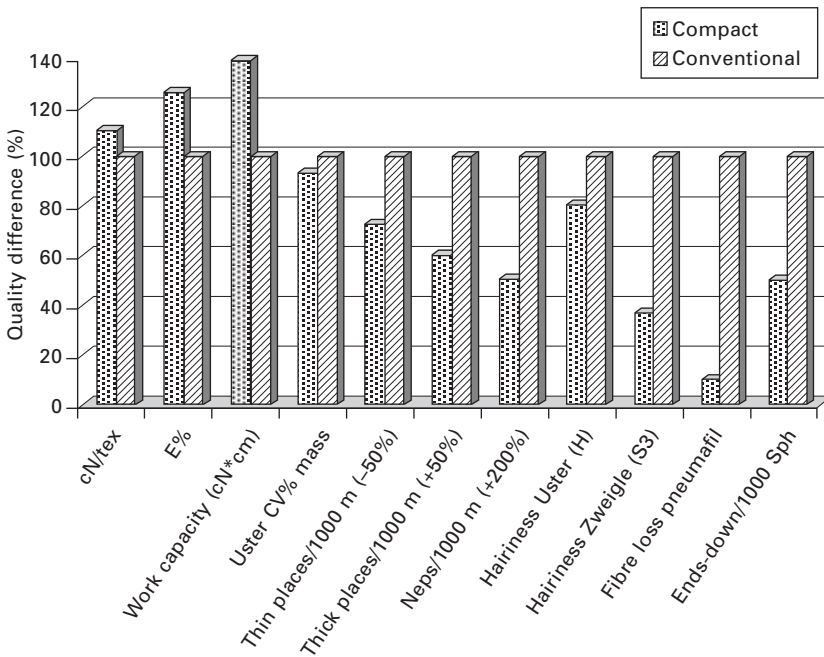

9.12 Quality difference between compact yarn and conventional ring yarn of 100% wool.

Another important feature is the performance on the loom after sizing. Even with a low performance in warping, the same yarn will perform much better than normal ring-spun yarn, so that loom efficiency is increased by

Table 9.1 Conventional vs. compact yarn in the warping process

	Conventional ring-spun yarn	Conventional ring-spun yarn	Compact yarn
Cotton fibre length	28 mm	32 mm	28 mm
Yarn count	40/1	40/1	40/1
Twist multiplier	4.30	3.60	3.80
Twist per inch	27.20	22.77	24.03
Strength (lb)	60.00	65.00	65.00
LCSP	2400	2600	2600
RKM	15.36	16.64	16.65
Warping breakage per million metres	0.70	0.90	0.70

about 4–5% with compact yarn because of low hairiness and slightly lower twist than that of conventional ring-spun yarn.

Yarn hairiness is a complex concept, which generally cannot be completely defined by a single figure. The hairiness occurs because some fibre ends protrude from the yarn body, some looped fibres are out from the yarn core and some wild fibres appear on the yarn surface. Hairiness of yarns has been studied for many years but has remained a debatable subject. The widely reported low hairiness of compact yarns compared to conventional yarns has raised again the issue of measuring hairiness and the proper interpretation of the measured values. The general consensus of opinion is that short hairs are desirable while long hairs are not (Clapp, 2001; Jabłoński and Jackowski, 2001; Jackowski *et al.*, 2003).

## 9.4 Advantages and limitations of compact spinning

### 9.4.1 Improved utilisation of fibre properties (raw material)

Thanks to better utilisation of the raw material, higher delivery rates can be achieved for equivalent yarn counts. The low level of hairiness and the smooth structure of compact yarns are evident right up to the end product, for example in terms of higher lustre or more marked colour contrasts in a fabric. Compact yarns, therefore, set an improved quality standard for end products; typically high-quality shirts demonstrate the improved yarn quality. Combed cotton yarns in the medium and fine count range are therefore being produced increasingly by the compact spinning method. The longer hairs in particular, which are a feature of conventional ring-spun yarns and disrupt downstream processing, are eliminated. Such yarns also offer an opportunity for substantial cost savings in the downstream processing stages.

The only limitation of compact spinning is that the rehabilitation from conventional ring spinning to the compact system needs more investment.

### *Cost saving in raw material*

An important claim is that with compact spinning the ends-down rate in spinning can be reduced by up to 50% (Kampen, 2000; Brunk, 2004), which clearly improves machine efficiency. The much reduced end breakage rate permits the reduction of the number of fibres in the cross-section, and thereby the spinning of finer yarn counts. This in turn means that lower-priced coarser fibres may be used to spin finer counts than would be the case for such fibres in conventional ring spinning (Kampen, 2002). It is therefore possible to use low quality cotton while maintaining yarn strength equal to that of conventional ring spun yarn with the same twist level. It is interesting to note that the improvements in yarn strength appear to be greater for long-staple coarse yarn count than for the extra-long staple, especially in the extra-fine count (El-Sayed and Sanad, 2007).

One of the reported advantages of compact spinning is the possibility of attaining yarn strength identical to that in conventional ring spinning but with an approximately 20% reduction (Suessen, 2002). This, in turn, means a softer yarn, increased production and reduced energy consumption.

The differences between the properties of compact and ring yarns i.e. strength, elongation and hairiness values being greater for carded yarns than for combed yarns (Stadler, 1995), mean that compact yarns have tremendous potential to offer several advantages both in spinning and in all subsequent processing stages compared to conventional ring yarns. This is because, with the low hairiness, fibre loss and fly contamination are much reduced and consequently a smoother, combed-like appearance can be achieved with carded cotton. Krifa and Ethridge (2003) reported that compact spinning made it possible to produce a 50 Ne carded yarn having tensile properties comparable to those of a combed yarn spun on the conventional frame. This important potential has also been raised (Artzt, 2000) but remains largely unexplored. In certain applications doubled yarns might be replaced by single compact yarns because of their improved appearance.

Although the above advantages are widely reported, there are viewpoints which contradict certain of these advantages. Importantly, there are concerns about the negative influence of the low hairiness. Kadioglu (2001) pointed out that the reduced hairiness might lead to more frequent traveller change, since hairs protruding from the yarn body provide lubrication and a cooling effect on the traveller and thus reduce traveller wear. This issue questions the economics of the compact ring spinning process. Also, despite claims that the system is very advantageous in spinning carded cotton yarns, other reports show it to be effective only for longer (or combed) fibres (Kampen, 2000).

## 9.5 Applications of compact yarn on downstream processing

### 9.5.1 Yarn preparation

In high-speed winding, the occurrence of increased hairiness, neps and fibre fly is reduced due to the higher resistance of the compact yarn structure to axial displacement of fibres. Where the singeing process is used to reduced yarn hairiness, this can be omitted for compact yarns or carried out at higher speeds.

In beaming for sizing the lower hairiness and high tenacity of compact yarns enable 30% reduction in the ends-down rate during beaming (Iftikhar, 2003).

### 9.5.2 Weaving

The weaving of short-staple yarns generally requires the warp yarns to be temporarily coated with a resin. The type of resin depends on fibre type (McCreight *et al.*, 1997); this resin is removed from the woven fabric by washing during subsequent finishing processes. The general term for the resin is 'size', and the process of applying it to the yarn is termed sizing. The purpose of the size is to bind hairs (short and long) to the body of the yarn. If not bound to the body of the yarn the hairs, and especially long hairs, and parts of the yarn of adjacent warp yarns can become entangled and disturb the shedding process during weaving, and this is one of the causes of warp breaks at the loom. Compact yarns have no long hairs, which allows easier sizing of the yarn (the amount of sizing agent needed can be reduced by up to 50%) and provides an effective shedding process. This results in cost saving in sizing as well as desizing, reducing fabric production cost. Due to the better work capacity of compact yarns, the ends-down rate in weaving can decrease by up to 50% in the warp and by up to 30% in the weft, which in turn increases efficiency in the range of 3–5% (Kampen, 2002) and reduces the weaving cost (Suessen, 2002). Besides these advantages, a better fabric is achieved because the cloth is almost free from loom start mark, due to far fewer loom stops.

### 9.5.3 Knitting

In knitting, the increased strength of compact yarns and the associated reduction in fly result in very low yarn breaks. There are therefore fewer interruptions, higher machine efficiency, and fewer fabric faults. In some cases the usual waxing of the yarns in knitting might be omitted. Owing to the improved fibre binding it is possible to reduce the twist of compact yarns for knitting by up to 20%, while maintaining yarn strength identical to that

in conventional ring spinning (McCreight *et al.*, 1997). In addition to the resulting increased yarn production rate, the reduction in twist will diminish spirally (Smekal, 2001) and give a softer handle to knitted fabrics.

#### 9.5.4 Dyeing and finishing

In the dyeing and finishing of compact yarn fabrics the reduced twist and enhanced yarn structure improve the absorption of colour pigments and chemical finishing agents. As a result, dyeing cost is reduced. It is possible to produce woven or knitted fabrics with great strength, high lustre and clear structures using compact ring-spun yarns (Kampen, 2000; Stadler, 2000; Smekal, 2001).

### 9.6 Future trends

#### 9.6.1 Self-cleaning apron system

Zinser CompACT<sup>3</sup> is one such development of self-cleaning aprons. Reportedly (Oerlikon Schlafhorst, 2008) this system gives more uniform and consistent yarn quality. Staff- and time-intensive inspections for quality assurance purposes are therefore much reduced (see Fig. 9.13).



9.13 Self-cleaning apron in Zinser CompACT<sup>3</sup>® system.

### 9.6.2 Plied yarn

Efforts to spin two-ply yarn directly on the ring spinning frame have been based on drafting two fibre strands in parallel but separated a relatively large distance apart. The two fibre strands are then combined immediately after passing the nip of the front rollers of the drafting system at the insertion point (Figs 9.14, 9.15 and 9.16), where they are both twisted in the same direction. This results in a plied or two-fold yarn with the same twist direction as the individual constituent strands. The level of the ply twist is 20% larger than the single strand twist, which is equal in both strands. Well known systems

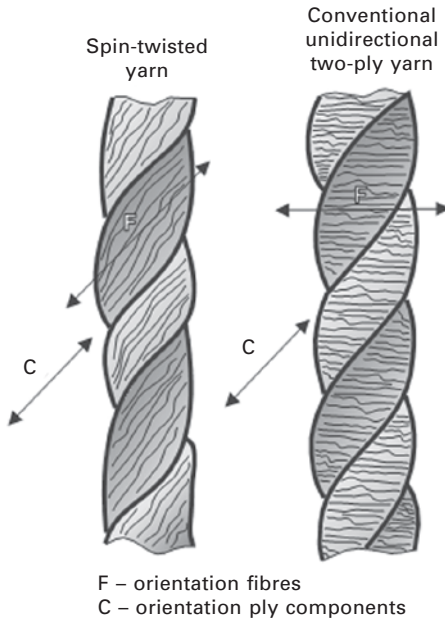

9.14 Differences between conventional unidirectional two-ply and spin-twisted yarn.

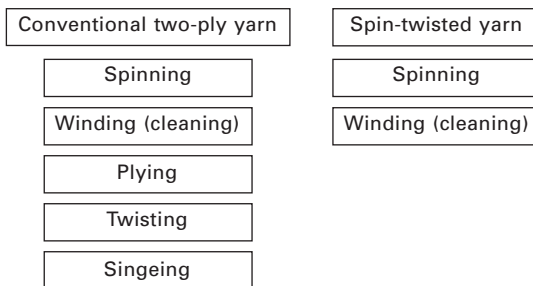

9.15 Workflow of conventional two-ply and spin-twisted yarn.

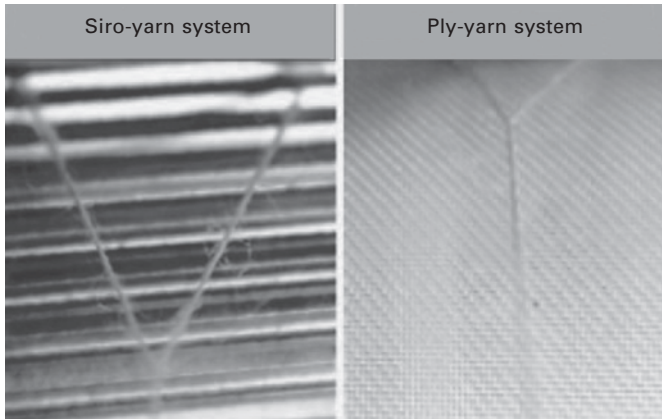

9.16 Twist insertion in spin-twisted yarn.

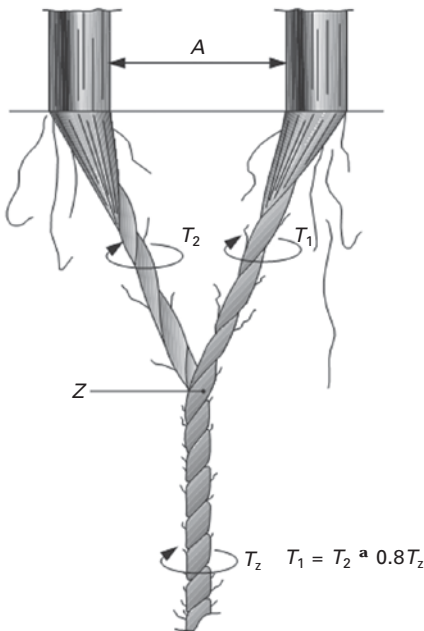

9.17 Spinning triangle of Siro-spun vs. EliTwist<sup>®</sup> plied yarn.

operating on this principle include the Siro-spun and Duospun systems. However, as shown in Fig. 9.17, the twist propagates upward through the two fibre strands and each fibre strand forms a long spinning triangle at the nip of the front roller. The dimensions of the twist triangle (height and width) typically depend on the distance between the twisting point Z and the nip point of the front roller pair, and the distance, A, between the two

emerging fibre strands. Typically, the closer the point Z to the nip point, the lower the spinning tension and the smaller the distance A between the two fibrous strands (Brunk, 2003, 2006).

Since the system is basically conventional ring spinning, it has the same problems associated with the spinning triangle discussed earlier. These include fibre loss at the drafting system exit, particularly important here because of the very low twist in the two strands. As a consequence, commercial systems of this type typically operate at slow speeds.

The compact spinning EliTwist<sup>®</sup> process, by reducing the twisting triangle, enables the restrictions mentioned above to be eliminated. In this system the two fibre strands initially pass a condensing zone. During condensing, both components get closer and reach a minimum distance by means of two suction slots in the condensing zone of a V-shaped arrangement. As a result, the two strands, after leaving the condensing zone, do not form spinning triangles. Consequently, no fibres are sticking out, to cause intermingling between the yarn components. The twist, running into the two yarn legs from the twisting point, does not need to overcome any such resistance and can easily reach the clamping line. As a result, the two fibre strands can be led very closely and the twisting point is a very small distance from the nip of the front roller pair. In short-staple spinning, this distance is only between 4 and 5 mm, depending on the spinning tension. One claimed merit (Suessen, 1999) of this system in comparison with the conventional Siro system is the substantial reduction in fly generation in the EliTwist system. The yarn surface and appearance of EliTwist are comparable to those of a single compact yarn. However, as the twist in the two yarn legs is identical, compact spun-plied yarn has a greater snarling tendency. Another advantage over conventional spin-plied methods is that no detection devices are required for the twisting triangle. In the case of a short-term material interruption at one of the two components, the broken component will piece up automatically due to the prevailing geometrical conditions.

The concept of plied yarn can also be applied to the production of core yarns by feeding a filament in the centre of the twisting triangle, i.e. directly at the twisting point as shown in Fig. 9.18. This enables complete covering of the yarn core (Brunk, 2003). It is also possible to feed additional threads parallel to one or both yarn legs.

## 9.7 Sources of further information and advice

- Artzt, P., 1997. The special structure of compact yarns – advantages in downstream processing. *ITB Yarn and Fabric Forming*, No. 2, 41–48.
- Barella, A. and Manich, A. M., 2002. Yarn hairiness: a further update. *Textile Progress*, Vol. 31, No. 4.
- El-Mogahzy, Y. and Chewing, C. Jr., 2002. *Cotton Fibre to Yarn Manufacturing Technology*. Cotton, Inc., Cary, NC.

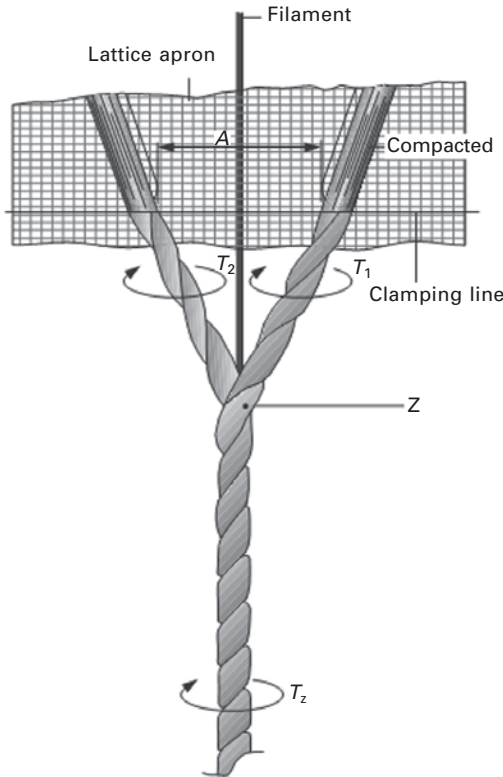

9.18 Core compacted yarn (Brunk, 2003).

- Grishanov, S.A., Harwood, R.J. and Bradshaw, M.S., 1999. A model of fibre migration in staple-fibre yarn. *J. Text. Inst.*, 90: 299–321.
- Gupta, B.S., 1972. Fibre migration in staple yarns. Part III: An analysis of migration force and the influence of the variables in yarn structure. *Text. Res. J.*, 42: 181–196.
- Hearle, J.W.S. and Bose, O.N., 1965. Migration of fibres in yarns. Part II: A geometrical explanation of migration. *Text. Res. J.*, 35: 693–699.
- Hearle, J.W.S. and Goswami, B.C., 1968. The migration of fibres in yarns. Part VI: The correlogram method of analysis. *Text. Res. J.*, 38: 781–790.
- Hearle, J.W.S. and Gupta, B.S., 1965. Migration of fibres in yarns. Part III: A study of migration in staple fibre rayon yarn. *Text. Res. J.*, 35: 788–795.
- Hearle, J.W.S., Gupta, B.S. and Goswami, B.C., 1965. The migration of fibres in yarns. Part V: The combination of mechanisms of migration. *Text. Res. J.*, 35: 972–978.
- Hearle, J.W.S., Gupta, B.S. and Merchant, V.B., 1965. Migration of fibres

- in yarns. Part I: Characterization and idealization of migration behavior. *Text. Res. J.*, 35: 329–334.
- Lawrence, C.A., 2003. *Fundamentals of Spun Yarn Technology*. Woodhead Publishing, Cambridge, UK.
- Morton, W.E., 1949. *An Introduction to the Study of Spinning*. Longmans, Green, London.
- Ratnam, T.V. and Chellmani, K.P., 1999. *Quality Control in Spinning*. The South India Textile Research Association, SITRA, India.

## 9.8 References

- Anon., 2001. *Spinnovation*, September, 6–7.
- Artzt, P., 1997. *International Textile Bulletin*, 2: 41–48.
- Artzt, P., 2000. The special structure of compact yarns – advantages in downstream processing. Reprinted from the *Proceedings of the Beltwide Cotton Conference*, Vol. 1, pp. 798–803. National Cotton Council, Memphis, TN.
- Barella, A. and Manich, A.M., 1997. Yarn hairiness update. *Textile Progress*, 26(4): 1–29.
- Brunk, N., 2003. EliTwist® – A compact yarn for superior demands. *Spinnovation*, 19 (October): 17–22.
- Brunk, N., 2004. Origin of ends-down in ring spinning. *Spinnovation*, 20 (June): 16–19.
- Brunk, N., 2006. EliTwist® – Three years after market introduction. *Spinnovation*, 22 (July): 10–16.
- Clapp, D.M., 2001. Suessen EliTe Ring Spinning Evaluation, *14th EFS System Conference*, North Carolina, March 2001.
- El Mogahzy, Y., 2004. Developments in textile technology: ITMA 2003 review. Part II: spinning machinery. *Proceedings of the Beltwide Cotton Conference*, Vol. 1, pp. 2692–2711, National Cotton Council, San Antonio, TX.
- El-Sayed, M.A.M. and Sanad, S.H., 2007. The impact of new spinning technologies on the Egyptian cottons. *AUTEX Research Journal*, 8(4), (December).
- Iftikhar, A., 2003. Compact yarn and warping – new concepts. *Spinnovation*, 19 (October): 32.
- Jabłoński, W. and Jackowski, T., 2001. Nowoczesne systemy przędzenia, Bielsko-Biała, Poland.
- Jackowski, T., Chylewska, B., Cyniak, D., Czekalski, J. and Pakulski, A., 2003. ‘Przędzepakompaktowe’ IV Międzynarodowa Konferencja Naukowo – Techniczna *Knitt Tech*, Szklarska Poręba, Poland, 5–7 June 2003.
- Kadioglu, H., 2001. Quality aspects of compact spinning. *Melliand International*, 7 (March): 23–25.
- Kampen, W., 2000. Advantages of condensed spinning. *Melliand International*, 6 (June): 98–100.
- Kampen, W., 2002. *Melliand English*, 6: E82–E83.
- Klein, W., 1987a. *A Practical Guide to Ring Spinning*. The Textile Institute Manual of Textile Technology, MFP Design and Print, Manchester, UK.
- Klein, W., 1987b. *The Technology of Short-staple Spinning*. The Textile Institute Manual of Textile Technology, Alden Press, Oxford, UK.

- Klein, W., 1993. Spinning geometry and its significance. *Int. Text. Bull., Yarn and Fabric Forming*, 39 (3rd Quarter): 22–26.
- Krifa, M. and Ethridge, D., 2003. Compact ring spun yarns: an examination of some productivity issues. *Textile Topics* (2): 2+,7 pages (Spring 2003).
- Krifa, M., Hequet, E. and Ethridge, D., 2002. Compact spinning: new potential for short staple cottons. *Textile Topics* (2): 2+,8 pages (Spring 2002).
- McCreight, D.J., Feil, K.W., Booterbaugh, J.H. and Backe, E.E., 1997. *Short Staple Yarn Manufacturing*. Carolina Academic Press, Durham, NC.
- Meyer, U., 2000. Compact yarns: innovation as a sector driving force, *Melliand International*, 6 (March): 2.
- Olbrich, A., 2000. The Air-Com-Tex 700 condenser ring spinning. *Melliand International*, 6 (March): 25–29.
- Oerlikon Schlafhorst, 2008. Zinser roving frames and customised process optimization. Zweigniederlassung der Oerlikon Textile GmbH.
- Oven, P., 1999. Spinning: wider future options. *Textile Month* (August): 16–18.
- Oxenham, W., 2003a. Spinning machines at ITMA 2003. *JTATM*, 3(3).
- Oxenham, W., 2003b. Developments in spinning. *Textile World*, May.
- Smekal, J., 2001. Air-Com-Tex 700 for compact spinning yarns. *Melliand International*, 7 (March): 18–19.
- Stadler, H., 1995. Compact spinning – a new generation of ring spun yarns. *Textilberichte Melliand*, 76(3): E29–E31.
- Stadler, H., 2000. New spinning process ComforSpin, *Melliand International*, 6 (March): 22–25.
- Stahlecker, F., 2000. Compact or condensed, a market niche or the summit of ring spinning. *Melliand International*, 6 (March): 30–33.
- Suessen, 1999. EliTe® Spinning System. Prospekt z wystawy maszyn włókienniczych. ITMA-99, Paris.
- Suessen, 2002. The Suessen EliTe® Spinning System brochure: 3–22.
- Wutthorst, B., 2000. Future developments in spinning. *Melliand International*, 6 (December): 270–272.

---

A. DAS and R. ALAGIRUSAMY, IIT Delhi, India

**Abstract:** During the past 40 years rotor spinning has established itself as an effective and important yarn manufacturing process. Rotor spinning overcomes all the problems of ring spinning by separating twisting and winding in the yarn manufacturing process. The success of rotor spinning is due on the one hand to a substantial increase in productivity, and on the other hand to the possibility of full automation of the spinning process. This is possible because rotor spinning combines three manufacturing processes, namely speed frame, ring spinning and winding. The present chapter gives a brief and precise description of rotor spinning. The process sequence in rotor spinning includes feeding of input sliver, opening of fibres to the individualized stage, transportation of fibres up to the rotor groove, and insertion of twist and winding of yarn. The process sequence, together with various important components, structure and properties of yarns, are described in detail.

**Key words:** fibre transportation, opening, opening roller, rotor, rotor diameter, rotor groove, take-off nozzle, twist insertion, yarn quality, yarn structure.

## 10.1 Introduction

Among the range of open-end spinning technologies, rotor spinning is commercially more widely used because a wider range of yarn counts can be spun with appropriate yarn properties. Since its commercial introduction in 1969, rotor spinning has developed continuously. Rotor speeds have increased from around 30,000 rpm to over 150,000 rpm. Rotor spinning was initially developed with two main objectives:

- To provide a more economical spinning system than conventional ring spinning through higher productivity
- To produce yarn of a quality that matches or surpasses that of conventional ring spinning.

The first objective has been accomplished. Today, rotor spinning has a production rate exceeding 200 m/min, as compared to a maximum of about 40 m/min in ring spinning. Rotor spinning eliminates the need for roving, since *rotor yarns can be spun directly from drawn sliver*. Unlike in a ring frame, the winding and twisting functions are separate and this permits the building of large yarn packages. Both these characteristics allow much higher

levels of productivity than with ring spinning. The second objective has not yet been achieved *because of the structure of rotor yarns, which also limits the fineness of count that can be spun*. Perhaps the biggest current obstacle facing rotor spinning is the fact that it is limited to coarse and medium yarn counts (16 tex to 120 tex) while ring spinning excels in the medium to fine counts (finer than 16 tex) [1].

## 10.2 Key features and operating principles of rotor spinning systems

The main features of a rotor spinning machine are illustrated in Fig. 10.1. They are:

- A feed roller and feed plate
- A saw-tooth or pin-covered roller called an opening roller
- A tapered tube known as a fibre transport channel
- A shallow cup called a rotor (which includes a groove cut into the circumference at the maximum internal radius of the rotor, referred to as the rotor groove)
- A flange tube facing the rotor base and co-axial to the rotor, termed the doffing tube
- A pair of delivery rollers that feed the spun yarn to the package build device

Fibres are presented to the rotor system in the form of sliver. The feed roller in combination with the feed plate pushes the sliver against the opening roller.

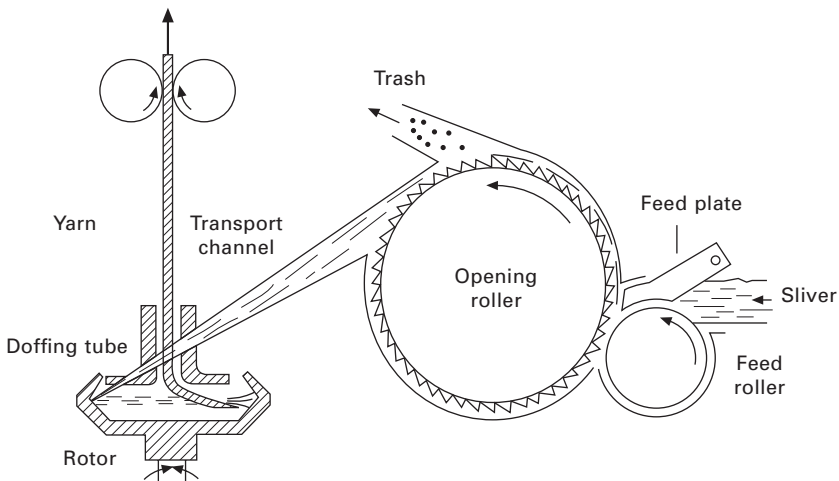

10.1 Main features of the rotor spinning system.

The opening roller rotates much faster than the feed roller. This means the fibres in the sliver are hooked by the saw tooth or pins and separated under a high draft ratio into individual fibres by the opening roller. The separated fibres are removed from the opening roller clothing by air suction flowing down the transport channel and into the rotor. Since the suction is generated externally to the rotor, the rotor is under a partial vacuum. The separated fibres are further drafted during their transportation by the air flow to the rotor.

The fibres are individually deposited onto the internal wall of the rotating rotor and slide *down* the wall and into the rotor groove, where they accumulate to form a ribbon of fibres. To initiate spinning, the tail end of the yarn (seed length) already wound on to the package (by the package build device) is threaded through the nip of the delivery rollers and into the doffing tube. The partial vacuum in the rotor sucks the tail end of the yarn into the rotor. The rotation of the rotor develops air drag and centrifugal forces on the yarn, pulling the yarn end in contact with the collected fibre ribbon. Simultaneously the tail end is twisted with each revolution of the rotor. This twist propagates towards the tail end of the yarn and binds the ribbon into the yarn end. Once the yarn tail enters the rotor, the delivery rollers are set in motion to pull the tail out of the rotor. The pulling action of the tail results in the peeling of the fibre ribbon from the rotor groove. The degree of twist inserted in the tail will propagate into each length of ribbon peeled from the groove, thus forming the next length of yarn. The process is continuous because of the conservation of mass flow [2].

The following sections look at individual stages in rotor spinning in more detail.

### 10.2.1 Preparation of the sliver

The sliver fed to rotor spinning machines usually has two drawframe passages after carding of 4 ktex count for most short staple fibres, although some machines can accommodate a feed of about 8 ktex. Generally a finer sliver is used for spinning finer yarns. For acrylic fibres which tend to be bulkier than other types of fibre, a 3 ktex sliver is used.

For the spinning of coarse yarn counts with short fibre lengths, i.e. <20 mm, card slivers can be directly fed to the rotor machine. However, for a suitable card sliver, double carding or an auto-levelling card should be used. The disadvantage in doing so is that the card production may be limited. An alternative is to blend a minimum of 20% of carrier fibre longer than 20 mm and to utilize a drafting zone built on the card which can apply a draft of 1.4 to 2.0. In this way up to 8 ktex sliver initially can be produced and then reduced to 4 ktex in the drafting zone, thereby enabling a greater card production rate. Fibre parallelization may also be improved in this way [3].

The need for the right quality of sliver determines whether one or two drawframe passages are required after carding for short staple fibres. Insufficient drawing passages result in an inferior yarn quality. Too many decrease the feed sliver cohesion. Satisfactory yarn strength and consistency is usually obtained most economically from two drawframe passages. The basic purpose of the drawframe passages is to obtain a uniform and well-blended sliver through the doubling action at the drawframe and, by the drafting action, to parallelize and straighten fibres, particularly those with hooked ends – whether leading, trailing or both ends. However, fibres with trailing hooks have less of a negative influence on rotor yarn strength and irregularity than on ring-spun yarns [3].

Semi-worsted type yarn used in heavy-duty fabrics such as upholstery, carpets, blankets and curtains is typically spun from 60–125 mm, 9–20 dtex manmade fibre. In this case, the card may be followed either by three intersecting gill boxes, the first with an auto-leveller, or by two gill boxes and one drawframe. Fewer doublings or a heavier feed sliver count gives poorer spinning results [3].

Waste fibres, such as cotton comber noil or card flat strips, are typically as clean, fine and strong as the longer fibres from which they have been removed, but may be too short for roller drafting. A typical mean fibre length in these cases is 9 to 12 mm. In such circumstances, the rollers may be fed with auto-levelled card sliver in which a small percentage of longer fibre has been blended [3, 4].

### 10.2.2 Opening methods

The opening roller removes the fibre from the sliver as it is fed in, and, after two or three rotations, delivers them to the feed tube in which the airflow takes them to the rotor. The trash particles are extracted by centrifugal forces in the first 90° of the opening roller revolution. The majority of rotor machines use a 50–80 mm diameter steel opening roller (also known as an opener, beater roller or disintegrator) which functions in a manner similar to that of the taker-in roller on a carding machine. It is designed to be fed by sliver usually ranging from about 40 to 300 times thicker than the yarn count to be produced, depending on the machine design. If fibre feed is too slow, particularly with thick sliver, the result is a longer operating time for the opening roller, leading to fibre damage and excessive dust formation. If the fibre feed is too fast, it will spend less time in the opening roller and opening will be inadequate.

The tooth shape (i.e. face angle and tooth tip configuration), surface roughness, frictional coefficient and opening roller speed are all critical for successful spinning. Basically the opening roller speed should be as low as possible. It is important to note, however, that too slow a speed tends to cause

fibre lapping and irregularity spaced thick and thin places in the yarn. On the other hand, increased opening roller speed causes higher dust formation, higher fibre damage, reduction in yarn strength and breaking elongation. It can even cause fibre melting in the case of thermoplastic fibres. This needs to be balanced with the fact that a higher opening roller speed also results in better trash extraction, better sliver opening, a reduced wrapping tendency, improved yarn evenness and lower imperfection (thick and thin places, neps) in the yarn [5, 6]. The opening roller surface speed is usually selected from within the range 800–2500 m/min, depending on the type of fibre and the roller design. A higher opening speed may be required to provide increased opening force in the following circumstances [3, 7]:

- Increased feed sliver count, even when the feed rate in mass per unit time is constant
- Increased fibre length
- The use of three-dimensional crimped fibre (compared with two-dimensional crimp)
- The use of finer fibres, because of the increased fibre surface area.

The card clothing used on the opening roller is usually of the rigid metallic type, varying from a face angle of about 65° and 18.5 points/cm<sup>2</sup> for cotton to 80° or 100° and 15 points/cm<sup>2</sup> for manmade fibres. Opening roller service life is considerably affected by the fibre material as well as by the dirt content in the fibre. The main wear points are the tooth face and tooth tip. Service life can be extended by the shape of the tooth (e.g. sickle shape, rounded tooth tip) and by tooth coating. Coated teeth show much lower levels of wear. Diamond-coated opening rollers have proved excellent in this respect. Removal of fibres from the opening roller is by controlled air flow, aided by centrifugal acceleration. The ratio of air speed to opener surface speed should be in the region of 1.5 to 4.0. The higher ratios result in higher yarn tenacities because of the improved fibre orientation.

### 10.3 Fibre transfer

After opening, the fibres are conveyed to the collecting surface of the rotor through a feed tube. Ideally the fibres should pass down the feed tube one at a time, but in practice the average number of fibres in the feed tube cross-section can be as many as four. If too many fibres are fed alongside each other, the rotor tends to accumulate tufts of fibres, thereby increasing yarn irregularity. The fibres passing along the feed tube are in a relaxed state. As a result fibre tensions are much more evenly distributed in the yarn, causing less fibre migration than in ring-spun yarns [8].

There are different possible positions of the feed tube relative to the rotor. Early rotor design used a central feed tube. The only advantage of this

arrangement was that it was possible to spin either S or Z twist merely by reversing the direction of the rotor rotation. On the other hand, with such an arrangement there were at least two right-angled turns in the fibre flow path which contributed to fibre bucking, as well as problems with air turbulence near the rotor centre and a greater incidence of wrapper fibre. In addition the rotor radius had to be at least equal to the maximum fibre length. As a result the disadvantages of this arrangement outweighed the one marginal advantage. Later designs have adopted a tangentially placed feed tube. The tube is usually tapered thinner towards the exit end so that the accelerating air aligns and straightens out the fibres before their leading ends emerge from the tube to contact the smooth surface of the faster-moving rotor slide wall which slopes at an angle of 20–40° to the rotor axis. This increases the likelihood that the fibres are fully straightened before they enter the actual collecting groove [3, 8].

The amount of rotation given to a fibre as it moves into the collecting groove depends on the rotor diameter, the slide wall angle, and the axial distance from the feed tube exit to the collecting groove. With a tangential feed tube, since the fibres are fed directly to the rotor circumference, they are less able to foul the length of gyrating yarn inside the rotor (as may arise with a central feed tube), but some bridging fibres and wrapper fibres are still unavoidable. A feed tube with the opposite angle of entry is needed if it is required to spin with the opposite direction of twist [3, 8].

### 10.3.1 The rotor

The important rotor parameters which have significant effects on the spinning process and yarn quality are:

- Fibre feed-in conditions (feed-in height relative to the rotor groove, feed-in direction, fibre feed-in speed relative to peripheral rotor speed)
- Rotor groove diameter
- Rotor groove shape (aperture angle, groove radius and depth)
- Rotor wall and rotor groove roughness
- Rotor wall inclination and surface quality
- Rotor speed.

The most important of these are rotor diameter and speed, the design of the rotor groove and the rotor wall. These are discussed below.

#### *Rotor speed and diameter*

Rotor speed depends, in part, on rotor diameter. Rotor speeds typically lie in the 120–210 m/s range, but mostly between 150 and 190 m/s, with a tendency to be higher with a smaller rotor diameter [6]. Currently the smallest

rotor diameter used industrially is 28 mm with rotor speed up to 150,000 rpm, though some machines can reach 160,000 rpm. Technically the rotor diameter is not dependent on yarn count or vice versa. However, a larger rotor is required for coarser yarns because they are frequently produced from relatively inferior cotton, which results in increased trash deposit in the rotor. A larger rotor diameter reduces the frequency of cleaning required to remove trash. The numbers of fibres deposited over the yarn peel-off point at each rotor revolution also increase as the rotor diameter decreases, which results in a higher number of overlapping fibres at the yarn peel-off point in the rotor groove. This overlapping fibre winding generates additional torque around the yarn axis, which counteracts twist migration in the rotor groove zone.

An increase in rotor speed results in improved spinning stability up to a specific maximum speed, depending on such factors as rotor diameter. However, too high a rotor speed results in poor spinning stability due to the large centrifugal forces on the fibres in the rotor groove which increase spinning tension and result in yarn breaks. Too low a rotor speed also results in poor spinning stability. If yarn tension is too low, the yarn twist cannot adequately propagate into the rotor groove.

Depending on the speed, a reduction in rotor diameter in the range from 56 mm to 28 mm results in higher productivity and lower energy consumption, but more irregularities in yarn structure (e.g. more belly band places) and reduced spinning stability with more yarn breaks.

Both rotor speed and rotor diameter affect spinning tension. Since yarn tension may not exceed a certain value because of the risk of increasing yarn breakages, rotor diameter must be reduced if faster speeds are required. With a smaller rotor and correspondingly increasing rotor speed, fibre contact pressure due to centrifugal force in the rotor groove increases. This makes twisting more difficult. In addition, embedded trash particles can only be removed with greater difficulty [6].

### *The rotor groove*

The configuration of the rotor groove has a pronounced effect on spinning stability, rotor groove dust loading and yarn quality. The most important parameters in this connection are groove radius, groove angle and groove surface roughness. The more open (depending on yarn diameter) and smooth the rotor groove, the better the yarn twist penetration, resulting in good spinning stability and bulkier yarns. Rotors with deep, narrow and rough grooves offer advantages in terms of yarn quality.

Three different types of rotor grooves are available: G-groove, S-groove and U-groove [9]. Figure 10.2 shows the shapes of different types of rotor groove. A G-groove rotor with a narrow groove is suitable for finer count

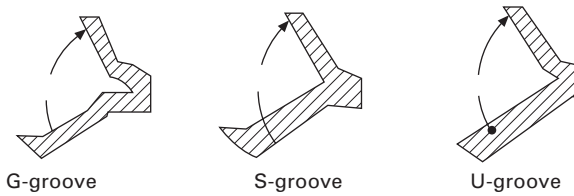

10.2 Different types of rotor grooves.

yarns providing the fibres are clean, since this design of groove is difficult to clean and has a tendency to produce moiré effects in the yarn. This type of groove is recommended for knitted yarns. The S-groove rotor has a sharp edge and is suitable for dirty cotton and coarser counts with less tendency to produce a moiré effect. The U-groove rotor has a wider groove suitable for coarser counts and produces a higher strength yarn than the S-groove.

### *The rotor wall*

The roughness of the rotor wall is determined by the rotor coating [5, 6]. A rough surface gives higher yarn quality. On the other hand, too much roughness with a small wall inclination angle may affect spinning stability. Rotor wall unevenness amplifies this effect. Suitable rotor geometry, precision production and the right fibre feed-in (closer to the rotor groove in the case of a small wall inclination angle) are important requirements.

### 10.3.2 The take-off nozzle

As has been noted, to start spinning, a seed yarn is introduced into the yarn tube until it contacts the collecting surface and becomes trapped in the strand of fibres. Yarn withdrawal then commences with the fibre layer peeled from the collecting surface. Continuity is maintained by the continuous stream of fibres arriving on the collecting surface to replace the fibres removed as the withdrawal point moves steadily around the collecting surface, usually in the same direction as the rotor rotation. This is termed normal withdrawal. The yarn follows a smooth curve and yarns of good appearance are produced. Occasionally there is a spontaneous change of motion of the yarn withdrawal point and it moves around the rotor in the opposite direction. This may be described as reverse withdrawal. In this case, because of air drag, the yarns form an 'S' curve and yarn appearance is adversely affected.

Theoretically one turn of twist is inserted for each revolution of the gyrating yarn end. It is important to note that the direction of twist insertion is determined by the direction of rotation of the rotor, that it remains unchanged

whether normal or reverse withdrawal takes place, and that the amount of twist inserted is virtually constant throughout the yarn package [3].

The yarn is withdrawn from the rotor through the take-off nozzle which protrudes into the rotor. The position of the take-off nozzle relative to the rotor has an effect on the quality of spinning. With a standard setting, the front edge of the take-off nozzle and the rotor groove should lie in one plane. Deeper take-off nozzle projection improves yarn quality to some extent but impairs spinning stability at the same time.

In order to achieve good spinning stability, it is important for the highest possible degree of yarn twist to be available at the yarn peel-off point in the rotor groove. This ensures a high yarn twisting torque and, as a result, the greatest possible yarn twist penetration into the rotor groove zone and, consequently, reliable twisting-in of the deposited fibres. The effect of the yarn take-off nozzle on twist diffusion into the actual spinning zone is very significant. In the rotor spinning process, the take-off nozzle plays about the same role as the lappet guide in ring spinning. It affects the degree of twist present in the rotor and therefore the spinning conditions in the rotor groove. Additionally, it exerts strong frictional forces on the yarn at the time of false twist release.

The materials used in take-off nozzles are generally ceramic and steel. Different configurations and their characteristics are:

- Smooth take-off nozzle:
  - Produces good yarn values and little hairiness
  - Should always be used if spinning stability allows it
  - Recommended especially for high twist yarns
  - Well suited for delicate fibres
- *Fluted take-off nozzle:*
  - Better spinning stability
  - Poorer yarn values with higher yarn hairiness
  - Best suited for low twist yarns with a high trash content
- Spiral take-off nozzle:
  - Improved yarn regularity
  - Reduced spinning stability
- Swirl take-off nozzle:
  - Increased yarn hairiness
  - Best-suited for knitted and terry fabrics.

## 10.4 Modern rotor spinning machines

The main differences between different rotor machine designs are:

- The method of opening and feeding
- The types of rotors and bearings used

- Whether they are designed for particular types of fibre and ranges of yarn count.

Other features include the following [10, 11]:

- Single-sided or double-sided machines
- Pneumatic transfer of trash to a common container at the end of the machine with duplicated waste filter units which permit cleaning without interruption of production
- Automatic control systems which stop the feed sliver when an end breaks. This leads to a significant reduction in the amount of spinning waste, an important economic advantage compared with ring spinning
- Automatic yarn length counters which actuate signal lamps to indicate the need for doffing, with an automatic synchronized stop if too long an overrun is permitted by the operative
- The use of air suction during doffing to hold spun yarn so that, on completion, the yarn forms the tail at the end of the package tube. In this way doffing can take as little as 30 seconds
- Sensors providing a yarn monitoring system which detects foreign fibres or other impurities in the yarn
- Laser-guided positioning systems
- Yarn waxing as part of the spinning process
- Automatic rotor cleaning with brushes at predetermined intervals
- A robot system which increases the contact pressure of the rotor belt briefly at an individual spinning position in order to accelerate the rotor. This ensures reliable and rapid acceleration during piecing. The machine can therefore be operated with significantly lower overall contact pressure along the whole of its remaining length. Lower overall belt contact pressure means reduced belt wear and reduced energy consumption
- A package transfer arrangement with two winding heads provided for each rotor so that the full package can be removed while the next package is being formed. This method may be most advantageous on long staple spinning machines for thick carpet yarns
- Automatic conveyance of full packages to the next stage.

## 10.5 Rotor spinning performance: yarn breakage

In addition to yarn quality, running performance plays a major role in evaluation of a spinning process. Running behaviour is often expressed in terms of the number of yarn breaks per unit mass of yarn. Spinning yarn breaks, and in fact all yarn breaks in general, are rare events. In rotor spinning, it is important to distinguish between different types of yarn break, which are attributed to quite different causes [12]:

- Spinning yarn breaks
- Tension yarn breaks.

Spinning yarn breaks occur in the yarn peel-off zone in the rotor when continuous fibre spin-in is interrupted. An increasing number of fibres remain at the yarn peel-off point in the groove and are no longer spun into the yarn end which becomes thinner, ultimately breaking. In the case of spinning yarn breaks, the main factor is sliver quality (e.g. impurities in the sliver) and uncontrolled fibre accumulations in the event of inadequate cleaning, especially in the trash extraction zone.

Tension yarn breaks take place in the already spun yarn, normally between the take-off nozzle and take-up rollers, leaving a short, broken yarn end in the rotor groove. The cause of tension yarn breaks is always excessive spinning tension, which affects the weakest yarn point i.e. the point, between the take-off nozzle and the take-up roller [12].

The stability of the rotor spinning process decides whether a problem such as trash particles, foreign fibres, dust, etc., will result in a yarn break or not. Spinning stability in rotor spinning is largely influenced by the following four factors:

- The numbers of fibres in the yarn cross-section
- Fibre length relative to rotor circumference
- The extent and degree to which yarn twist can penetrate into the rotor groove (twist-in zone length)
- The speed and reliability with which the fibres move from the impact point on the rotor wall to the rotor groove.

For better spinning stability, all fibres at the yarn peel-off point in the rotor groove must be continuously spun into the rotating yarn elbow. Adequately high yarn torque, i.e. an adequately high degree of yarn twist in the yarn end, is necessary to this end.

## 10.6 Structure and properties of rotor spun yarns

Rotor spun yarns are well known for their unique three-part structure:

- Wrapper or belt fibres
- Sheath fibres
- Core fibres.

The core contains densely packed fibres similar to ring-spun yarns. Sheath fibres are loosely packed round the yarn core at a low angle to the yarn axis. The wrapper or belt fibres are wrapped around the outside of the yarn at a very large inclination to the yarn axis. It has been reported [13] that fibre migration in rotor yarn is relatively local: fibres in each layer are tied only

to the fibres of adjacent layers. Rotor spinning generates lots of hooks and looped fibres even if a well-parallelized sliver or roving is fed into the rotor. The typical distribution of fibre shapes in rotor spun yarn is 39% folded or buckled fibres in the core, 31% straight fibres in the core, 15% leading hooks and 15% trailing hooks in the outer layers [13].

Given its structure, fibres in rotor yarn are less packed than in ring yarn. Rotor yarns are known to be 5–10% bulkier than ring yarn. Across the cross-section, the packing is not uniform. The packing is maximum at a point approximately one third to one quarter of the yarn radius from the central axis. This has been attributed to greater buckling of fibres in the core. As a result, packing of rotor yarn is concentrated nearer the yarn axis and less towards the outer surface of the yarn in comparison to ring spun yarn [13].

Rotor spun yarn is less strong than comparable ring spun yarn. This is because of the straight, parallel arrangements of fibres and the denser packing of fibres in ring spun yarn which contrast with the higher numbers of disoriented folded fibres in rotor spun yarn, lower levels of fibre migration, less packing and the presence of non-load-bearing wrappers and belt fibres.

Rotor spun yarns are generally more extensible than ring spun yarns. The higher breaking extension of rotor yarn is due to the presence of a lot of hooked, looped and disoriented fibres in the structure. However, the dense, more tangled structure of fibres in the core offers very little freedom of movement of fibres in rotor yarns. Rotor yarns are therefore less flexible than ring yarns, which have a more uniform helical arrangement of fibres.

Due to its unique structure, rotor yarn shows higher abrasion resistance than ring spun yarn. The loosely wrapped sheath fibres can easily yield to an abrasive surface, and, given its greater bulk, the yarn can flatten, giving further abrasion resistance. Rotor yarns also have fewer irregularities and imperfections compared to carded ring-spun yarns. This has been attributed to the mechanism of yarn formation, i.e. back doubling in the rotor groove before twist insertion, which irons out irregularities.

## 10.7 Conclusions

In this chapter, the fundamental principle of rotor spinning is explained in detail. The advantages of rotor spinning in comparison to ring spinning are explained. The structure of yarns produced with rotor spinning is analysed and the end-uses for these yarns are provided. The working principle of the rotor spinning system is explained in detail with its specific features. The structure and properties of yarns produced with rotor spinning are compared with those of ring spun yarn. The major limitation with the rotor spinning technology is that it is suitable for spinning coarser yarns and also that yarn strength is poor compared to that of ring spun yarns due to relatively

random alignment of fibres, although this method of yarn production has very high production rates and yields more uniform yarns compared to ring spinning technology.

## 10.8 References

1. El Mogahzy, Y. and Gowayed, Y., 1995, Theory and practice of cotton fibre selection. Part II: Sources of cotton mix variability and critical factors affecting it. *Textile Research Journal*, 65: 75–84.
2. Lawrence, C. A., *Fundamentals of Spun Yarn Technology*. CRC Press, Boca Raton, FL, pp. 281–342.
3. Oxtoby, E., 1987, *Spun Yarn Technology*, Butterworths, London, pp. 138–212.
4. Lord, R. P., 2003, *Hand Book of Yarn Production*. The Textile Institute, Manchester, UK, pp. 185–211.
5. Deussen, H., 1993, *Rotor Spinning Technology*, Schlafhorst Publications, Charlotte, NC.
6. Trommer, G., 1995, *Rotor Spinning*, Deutscher Fachverlag GmbH, Frankfurt am Main.
7. Hunter, L., 1978, The production and properties of staple-fibre yarns made by recently developed techniques. *Textile Progress*, The Textile Institute, Volume 10, No. 1/2.
8. Lord, P., 1981, *The Economics, Science and Technology of Yarn*, NCSU, Raleigh, NC.
9. Haranhalli, A. S., 1990, *Practical Open End Spinning*, Mahajan Book Distributors, Ahmedabad, India.
10. Weidner-Bohnenberger, S., 2005, R40 with AEROpiecing breakthrough in piecing quality. *Asian Textile Journal*, 14(8): 67–68.
11. [www.rieter.com](http://www.rieter.com)
12. Ishtiaque, S. M. and Das, A., 2004, End breakage in rotor spinning: effect of different variables on cotton yarn end breakage. *AUTEX Research Journal*, 4(2): 52–59.
13. Ishtiaque, S. M., 1989, Longitudinal fibre distribution in relation to rotor-spun yarn properties. *Textile Research Journal*, 59(11), 696–699.

---

A. A. MERATI, Amirkabir University of Technology, Iran

**Abstract:** The friction spinning system with low spinning tension is suitable for the production of yarn at high speeds up to 500 metres per minute. This system produces multicomponent yarns from a wide range of different fibres for technical applications. This chapter describes the fundamental principles of the friction spinning process, and reviews the research findings of the effect of the raw materials, machine and process parameters on the spinning performance, yarn structure and properties. Consideration is given to the various fibre types that can be spun by this method and the wide range of applications for friction spun yarns.

**Key words:** open-end friction spinning, fibre, multicomponent yarn, twist efficiency, spinning tension.

## 11.1 Introduction

### 11.1.1 Definition and background

Friction spinning is defined as an ‘open-end’ spinning method (or an OE spinning method), in which the yarn formation takes place in the yarn forming zone consisting of two friction rollers with the aid of frictional forces. In traditional spinning systems the fibre supply is first formed into a strand of fibres, almost equal to the final count of the yarn, and then twist is inserted to form the yarn. With OE friction spinning the fibre supply must be opened completely into individual fibres and reassembled at the nip line of the two friction rollers to form a twisted strand of fibres, i.e. the yarn, each fibre being twisted onto the forming strand by the friction rollers as soon as it reaches the nip line. While the production speeds are limited with both ring and rotor spinning, the friction spinning system has a low spinning tension and is therefore suitable for the production of yarn at high speeds of up to 500 metres per minute.

The first patented friction-spinning system was granted to Platt-Saco-Lowell in 1967. The company much later developed and introduced their friction-spinning machine, called the Masterspinner, at the 1983 ITMA exhibition in Milan (Ishtiaque *et al.*, 2003a). An alternative friction-spinning system was also developed by the company Ernst Fehrer and exhibited in 1973 under the name of DREF-1. With this system, the opened fibres were made to fall on a vacuum slot of a single perforated cylindrical roller, the rotation of

which imparted twist to the fibre assembly (Lünenschloss and Brockmanns, 1985). Owing to the absence of positive control over the assembly of fibres, much slippage occurred between the fibre assembly and the perforated roller, which reduced the twist efficiency. Hence this particular design could not be commercialized. In order to reduce slippage and improve the twist efficiency, the concept of enclosing the fibre assembly between two perforated friction rollers was devised, and formed the basis for the commercial development of two designs of DREF spinning machines, known as DREF-2 and DREF-3. The DREF-2 machine was demonstrated at the 1975 ITMA exhibition and then commercialized in 1977. The DREF-3 machine was introduced on the market at the end of 1981 (Gsteu, 1985). The DREF-3 machine was developed basically to improve the yarn quality, extend the yarn count towards the finer end of the count range (up to 33 tex), and produce multicomponent yarns.

As an improvement in respect of the vertical fibre-feeding arrangement that exists in DREF-2 and DREF-3 machines, the DREF-5 friction-spinning machine was developed jointly by Schlafhorst, Suessen, and Fehrer. The DREF-2000 and DREF-3000 are the latest development in friction spinning. Since 1967, many friction-spinning systems have also been patented by various companies and individuals. Although these machines have different modes of operation, their basic principle is similar.

### 11.1.2 Principle of operation

The friction-spinning system is based on the principle of open-end spinning, which consists of the following operations: feeding a sliver of fibres into the spinning system, separating the sliver into individual fibres (i.e. opening), reassembling the individualized fibres, twisting the reassembled fibres to form the yarn, and winding the yarn onto a bobbin to form a yarn package. In an open-end friction-spinning process, a feeding channel is provided to convey the individualized fibres from an opening cylinder into the nip of the yarn forming zone. The fibres are twisted together into a yarn, alongside a suction slit in the yarn forming zone generally formed by two friction rollers, in close proximity with each other and driven in the same direction. The process is assisted by air suction through the roller perforations. The resultant yarn is withdrawn from the nip of the friction rollers and wound on a package.

In the design of the Masterspinner the sliver is opened into individual fibres by a pinned beater and then transferred by a transport channel to the yarn forming zone at a 25–28° angle by means of suction through the perforated roller. Two friction rollers are used to insert twist into the reassembling fibres: one is a hollow roller having a perforated surface and an internal suction slot positioned parallel to the nip line, and the other is a solid roller, which provides effective friction transfer. The Masterspinner is capable of

processing fibres up to 40 mm long, producing yarns over the count range of 15–59 tex at delivery speeds of up to 300 m/min.

The DREF-2 friction spinning machine (Fig. 11.1) essentially consists of a specially designed feeding system, which retains the slivers and provides the required draft. These drafted slivers are opened into individual fibres by a rotating opening roller. The individualized fibres are transferred into the nip of two perforated friction rollers, where they are held by suction. The fibres are subsequently twisted by mechanical friction on the surfaces of the friction rollers. The low yarn strength and the requirement of having more fibres in the yarn cross-section have restricted DREF-2 spinning to the coarser count range of 98–1181 tex.

Unlike the DREF-2 and the Masterspinner, the DREF-3 is a core–sheath type of friction-spinning arrangement as shown in Fig. 11.2 (Fehrer, 1991). On this machine, there are two drafting units, one for the core fibres and the other for the sheath fibres. This system produces a variety of core–sheath types of structure and multicomponent yarns, through selective combination and placement of different materials in the core and sheath in the count range of 33–591 tex, with delivery speeds as high as 300 m/min.

With the DREF-5 friction-spinning machine, the individualized fibres from a single sliver are fed through a fibre transport channel into the yarn forming zone at an inclined angle to the yarn axis (Fig. 11.5). At present, the DREF-5 system is the optimum technical solution for the production

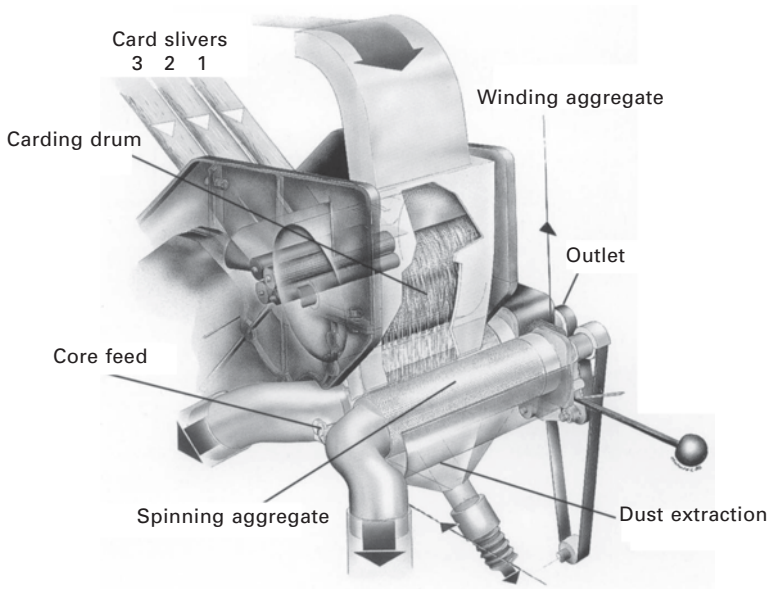

11.1 The DREF-2 friction-spinning machine (Fehrer, 1994).

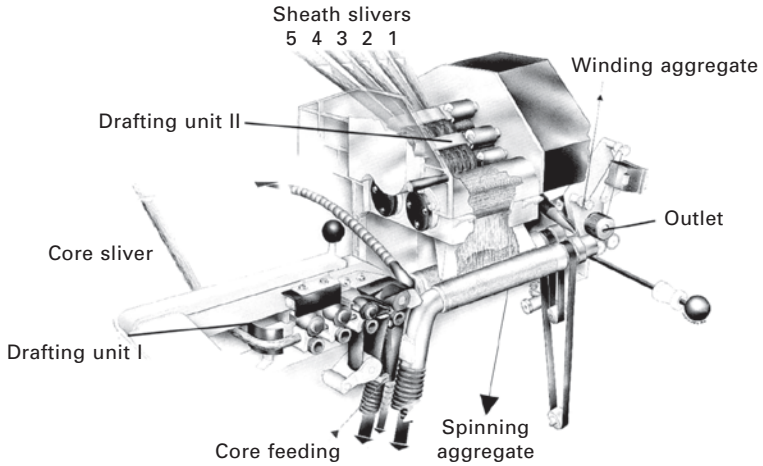

11.2 The DREF-3 friction-spinning machine (Fehrer, 1991).

of the best quality friction yarns within the count range of 15–37 tex, with production speeds of up to 200 m/min.

The DREF-2000 friction-spinning machine employs the classic DREF-2 system. This machine can produce S- and Z-twisted yarn without mechanical alterations to the machine by the operator. Yarns of 41 tex can be produced at production speeds of 250 m/min (Ishtiaque *et al.*, 2003a). DREF-2000 friction spinning machines are utilized for recycling textile wastes as well as the spinning of technical and other yarns.

The DREF-3000 friction spinning machine, the latest model of the machine, is utilized especially for the production of multi-component yarns (hybrid yarns) of count 33–666 tex with production speeds of up to 250 m/min. This machine has a filament guide and is capable of operating with several yarn cores, which are axially fed to the spinning drums. These core yarns are then provided with a fibre sheath and are positioned precisely in the middle of the yarn.

## 11.2 Yarn formation on friction-spinning machines

Slivers are prepared for friction spinning in a similar way as those for rotor spinning, except that finer slivers are used. The fibre feeding device, the fibre transport device and the twisting device are the three main operating stages of friction spinning systems.

### 11.2.1 Fibre feeding device

The fibre feeding device performs drafting and fibre individualization. In the DREF-2 and DREF-2000 friction-spinning machines, two pairs of feed

rollers retain the slivers (normally five) and provide the required drafting. The drafted strands of sliver are opened and individualized into fibres by a rotating opening roller (Fig. 11.3).

The DREF-3 friction-spinning machine consists of two roller drafting units (Fig. 11.4). Drafting unit I, which consists of three drafting zones, attenuates the core sliver and feeds the fibre strand into the entry of the spinning nip along the direction of the yarn axis. It is also possible to feed a filament, an elastomer, or a wire as the core component. Drafting unit II consists of two pairs of rollers, which draft the sheath slivers. The fibres of the drafted slivers are then individualized by a pair of opening rollers or carding drums, where the shortest distance between the clamping line of the last pair of feed rollers and the line of strike for the two carding drums is approximately equal to the fibre length (Fig. 11.4). The opening rollers rotate at 12,000 rev/min and have a saw-tooth wire covering. The angle of tooth inclination is  $10^\circ$  for synthetic fibres and  $20^\circ$  for cotton.

In the DREF-5 friction-spinning machine, the drafting unit consists of a feed roller and pedal, which retain the sliver and feed them to a combing roller which rotates at speeds of 4500–5000 rev/min and individualizes the sliver into fibres (Fig. 11.5).

### 11.2.2 Fibre transport device

The fibre transport device feeds the individualized fibres into the yarn forming zone. The individualized fibres are transferred by air flow through

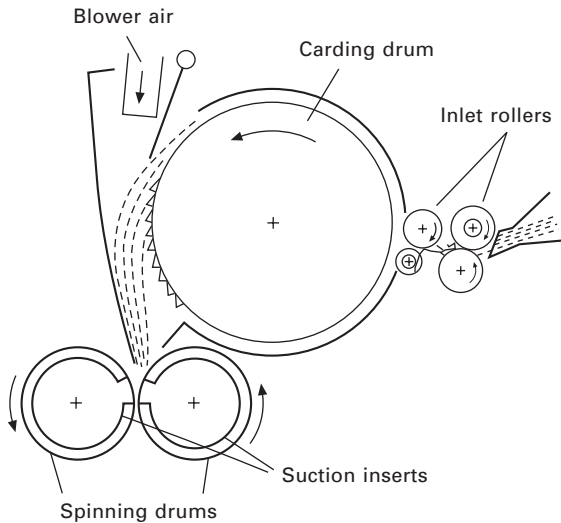

11.3 Schematic diagram of the DREF-2 friction-spinning machine (Fehrer, 1987).

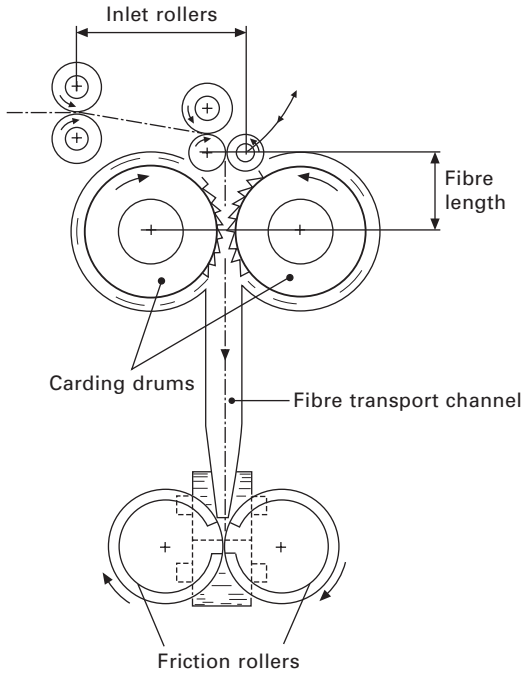

11.4 The fibre-opening and feeding device of the DREF-3 friction spinner (Fehrer, 1987).

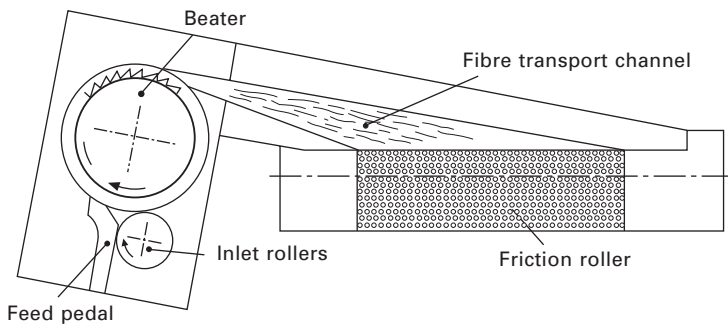

11.5 Schematic diagram of the DREF-5 friction-spinning machine (Fehrer, 1987).

the transport channel and deposited in the nip of the friction rollers. There are two modes of fibre feed, namely vertical feed and inclined fibre feed. DREF-2 and DREF-3 have vertical feed systems (Figs 11.1 and 11.2), whereby the fibres are fed at right angles to the yarn axis. The Masterspinner employs an inclined fibre feed known as the backward-feed system, but the DREF-5 unit (Fig. 11.5) has an inclined fibre feed known as the forward-feed system.

The mode of fibre feeding has a definite effect on the fibre extent and fibre configuration in the spun yarn and ultimately on the yarn properties. The inclined fibre feed offers advantages such as better fibre-length utilization and the spinning of finer yarns. However, the vertical feed results in the production of stronger but coarser yarns.

In friction spinning with divergent transport channel, the air velocity in the channel decreases and the fibres are 'compressed' and decelerated, which results in buckling and disorientation of fibres. Because of the machine structure, the yarn forming zone has a certain length and it is difficult to decrease the channel cross-section with a certain width to provide a convergent channel. In this regard, several attempts were made to find ways to deposit the fibres in as straight a condition as possible on the friction rollers.

To improve fibre alignment along the yarn axis, a 'Parallelisator' or 'Paradisc' (Fig. 11.6(a)) was developed by Fehrer that results in improved yarn strength (Lünenschloss and Brockmanns, 1985). The use of compressed-air injection in the fibre-feeding channel proposed by Barmag and the subsidiary suction used by Platt-Saco-Lowell (Figs 11.6(b) and (c)) led to improved fibre alignment in the feed channel (Lünenschloss and Brockmanns, 1985). The inclined fibre transport channel and backward spinning method incorporated in the Masterspinner help to reduce the fibre buckling in the yarn forming zone and also enable feeding of a single sliver to take place and hence allow the spinning of finer yarns. Fehrer, in a joint venture with Suessen and Schlafhorst, incorporated the inclined fibre transport channel and forward spinning method in the DREF-5. By modifying the design of the transport channel, the air flow inside the channel as well as the arrangement of fibres in the yarn and the yarn properties were improved (Merati and Okamura 2000a,b). Merati and Okamura (2000a) designed a convergent channel on a backward spinning system which led to improved fibre extent in the yarn and of the yarn strength (Fig. 11.6(d)). They concluded that the strength and fibre extent of the yarns made by the convergent transport channel are higher than those made by the divergent channel.

The assembly of fibres at the yarn formation zone determines the yarn structure and its properties. Lord and Rust (1991a,b) studied the fibre assembly and proposed that there can be at least two methods of assembling the incoming fibres (Fig. 11.7). One way is that the fibres assemble completely on the perforated roller before their transfer to the rotating sheath (Fig. 11.7(a)). The other is that the fibres are laid directly onto the rotating sheath (Fig. 11.7(b)). A straight, unfolded fibre can attach to the yarn tail by its head or tail. The probability that a fibre will be positioned in the yarn by its head or tail, toward the yarn take-up direction, is related to its position in the transport channel or yarn forming zone where the fibre is subjected to capture. Merati *et al.* (1998a, 2000) used the tracer fibre technique to characterize fibres landing on the yarn tail by considering the position of

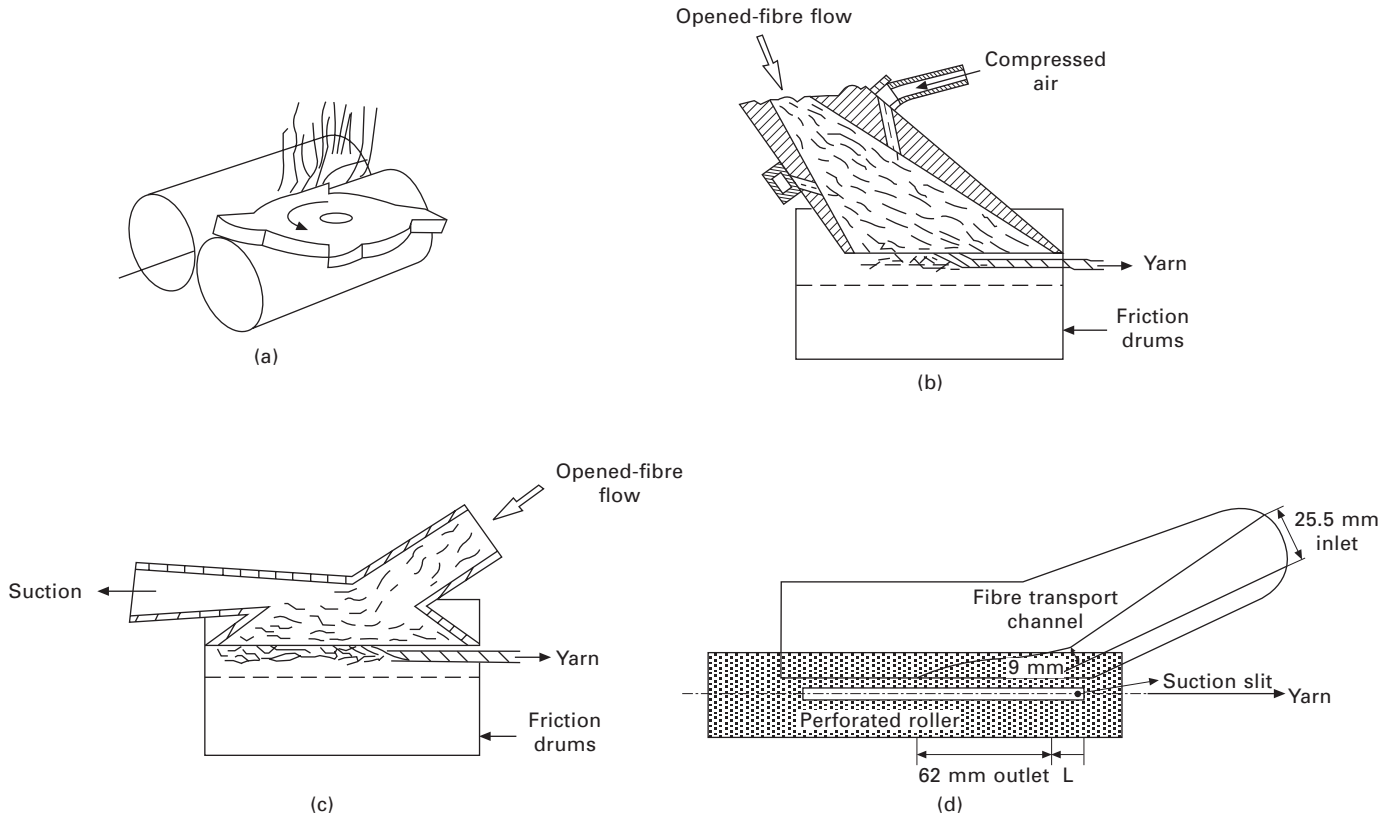

11.6 Developed fibre transport devices: (a) Paradisc by Fehrer; (b) pneumatic (forward spinning) by Barmag; (c) pneumatic (backward spinning) by Platt; (d) convergent channel by Merati (Lünenschloss and Brockmanns, 1985; Merati and Okamura 2000a,b).

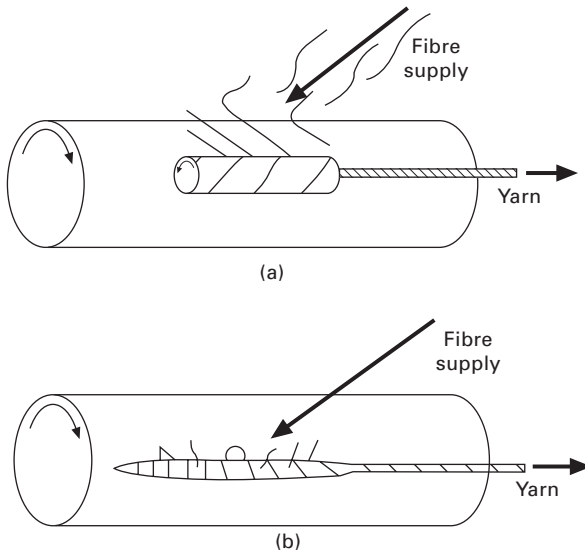

11.7 Methods of fibre accumulation: (a) indirect method; (b) direct method (Lord and Rust, 1991b).

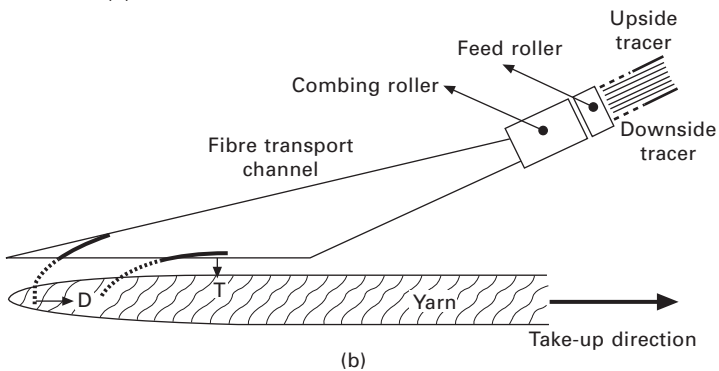
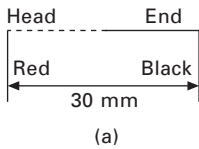

11.8 (a) Tracer fibre; (b) schematic of a simplified model of fibre landing behaviour in the yarn forming zone (D = the yarn tail drawing the fibre, T = the fibre trapping itself on the yarn tail surface) (Merati and Okamura, 2000a).

the tracer fibres in the yarn structure. In their research, small quantities of fibres coloured half red and half black were added to the cotton sliver to act as tracers (Fig. 11.8(a)). They showed that there are two kinds of landings.

A fibre positioned in the upside of an inclined transport channel will have a landing angle bigger than that of one positioned in the downside of the transport channel and partly extended along the channel upside body. Hence, the fibre head can be captured by the yarn tail, and then the yarn tail can draw it into the yarn forming zone (Fig. 11.8(b)). This kind of capture is called ‘drawing by the yarn tail’, where it will be positioned in the yarn by its head, toward the yarn take-up direction. A fibre positioned in the downside of the transport channel is positioned in the downside body of the flow, and its landing angle is lower than that of the upside of the transport channel and partly extended along the yarn tail (Fig. 11.8(b)). Although this fibre can be captured by its head and then the yarn tail will draw it into the yarn forming zone, it can also trap itself onto the surface of the yarn tail. This mechanism occurs because of the presence of the suction in the nip, which draws the fibre onto the surface of the yarn tail. This kind of capture is called ‘fiber trapping on the yarn tail surface’. Hence, the probability that a fibre fed from the upside of the transport channel will be positioned in the yarn by its head, toward the yarn take-up direction, is greater than that of a fibre fed from the downside of the transport channel. Most of the fibres fed from the upside of the transport channel will be incorporated into the tip of the yarn tail (referred to as drawing-in) and form the yarn core, while the probability of both drawing-in and trapping is almost equal for fibres fed from the downside of the transport channel which form the yarn sheath.

### 11.2.3 Twisting device

The twisting device consists of two friction rollers with surface motion in opposite directions. The motion of the friction rollers twists the fibre assembly and strengthens it. The resulting ‘twist potential’ does not correspond to the ratio of yarn diameter to friction roller diameter, as about 80–90% of it is lost through slipping. The slip or loss in frictional contact between the friction roller and yarn surfaces in the yarn forming zone is given by (Brockmanns and Lünenschloss, 1984b):

$$S = \{1 - (T_a/T_{th})\} \times 100\% \quad 11.1$$

where  $S$  = mean slip (%),  $T_a$  = actual twist ( $m^{-1}$ ) and  $T_{th}$  = theoretical twist ( $m^{-1}$ ). Konda *et al.* (1996a) expressed twist efficiency as a percentage of yarn tail rotation in contact with the friction rollers without slipping, and defined it as

$$\alpha = (TPM \times d \times V_y \times 100) / (RPM_f \times D_f) \quad 11.2$$

where  $\alpha$  = twist efficiency, TPM = practical yarn twist ( $m^{-1}$ ),  $d$  = practical yarn diameter (mm),  $RPM_f$  = friction roller speed (m/min),  $D_f$  = friction roller diameter (mm), and  $V_y$  = spinning speed (m/min). They indicated that

the twist efficiency increases with increased air suction pressure. However, the twist efficiency depends on many factors, including machine, process and raw materials parameters.

For a stable spinning process, the frictional forces acting between the yarn surface and the two rotating friction rollers should be, as far as possible, equal in value (Fehrer, 1987). The design and adjustment of friction rollers have a considerable influence on yarn formation and ultimately on yarn properties (Lünenschloss and Brockmanns, 1985). The most important design parameters of the friction rollers that influence yarn formation are the shape, length and diameter of the friction rollers, the use of one or two perforated rollers each with suction at the spin-line, the hole size and percentage of perforations in the total roller surface, the finish of the friction roller surface, the adjustment of the suction cover plates, and the stiffness and frictional properties of the rubber coating of the solid friction roller when used with one perforated friction roller. The important process parameters that influence yarn formation and twisting efficiency are the air suction pressure, the dimensions and geometry of the nip between the friction rollers, the ratio of the friction roller surface speed to the yarn-take-off speed, the ratio of the rotating speeds of the two friction rollers, the direction of rotation when only one suction roller is used, the fibre-feeding device, and the gap between the friction rollers and the direction of yarn take-off (Wei, 1996; Merati and Okamura, 2005b).

Shantong (1990) stated that the frictional force that occurs between the friction roller surface and the yarn surface in the yarn forming zone is of two forms, namely sliding friction and rolling friction. The frictional forces acting on the yarn and friction rollers are calculated according to Coulomb's law of friction by multiplying the normal forces, which result from suction at the nip acting on the contact areas of the yarn and the friction coefficients of the two friction rollers as shown in Figs 11.9 and 11.10.

In DREF friction spinning, the spinning aggregate consists of two DREF-specific perforated friction rollers rotating in the same direction. Each perforated roller consists of an inner stationary cylinder with a slit at the nip, which helps in creating the air suction pressure. The air suction pressure has a restraining influence on the fibre assembly in the spinning zone while it is being rolled and twisted. However, when only one friction roller is perforated (Fig. 11.10), the stiffness and frictional properties of the rubber coating play an effective role in steadiness of yarn formation. The surfaces of the friction rollers have a special structure to attain a better twist effect. A nickel-diamond coating protects the surface structure from wear and tear. The maximum speed of the friction rollers is 5000 rev/min.

The normal forces between the yarn and the moving roller surfaces locally within the yarn forming zone mainly depend on the yarn diameter, the coefficient of friction, and suction air pressure at the location. Figure

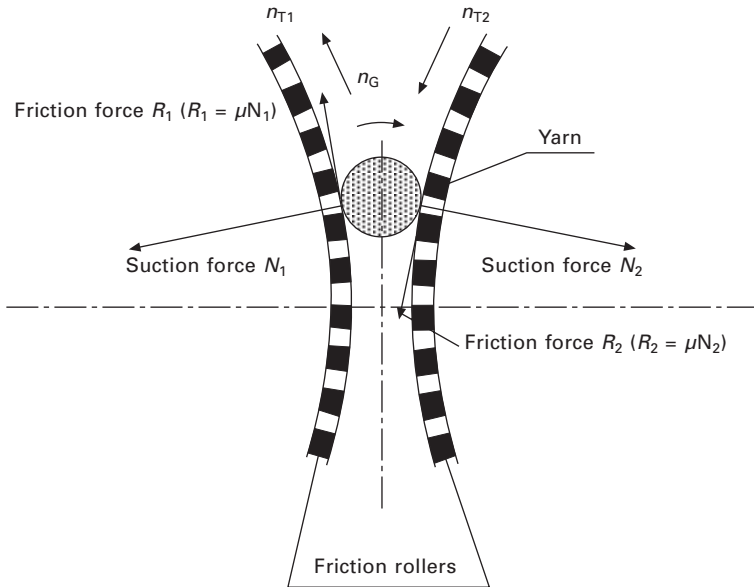

11.9 Diagram of forces acting on yarn in the yarn forming zone (Fehrer, 1987) ( $\mu$  = dynamic coefficient of friction between the perforated roller and the yarn,  $n_{T1}$  and  $n_{T2}$  = rotational speeds of the friction rollers,  $n_G$  = rotational speed of the yarn tail).

11.11 shows the distribution of torque needed for twisting along the yarn tail produced by normal forces in the yarn forming zone (Figs 11.9 and 11.10(a)). They also produce the drag forces which results in spinning tension (Fig. 11.10(b)) (Merati *et al.*, 1997).

The yarn tail in the yarn forming zone can be considered as a loosely constructed conical mass of fibres, formed at the nip of the friction rollers. Lord and Rust (1991a,b) concluded that the yarn tail is enlarged and torpedo-shaped, being squashed by the nip of the perforated friction rollers, and the fibres on its surface are loosely wrapped to the extent of being looped around it. Moving away from the tip, these wrappings were shown to become tighter (Fig. 11.12).

Kato *et al.* (1999) analysed the yarn-tail structure in the yarn forming zone of a friction-spinning machine by considering the shape of individual fibres in the yarn, with the help of photographic and tracer-fibre techniques. They tried to demonstrate that the shape of the yarn tail in friction spinning could be obtained from the fibre configuration in the yarn structure. They found that the yarn tail in the yarn forming zone has a complex shape. The tip of the yarn tail is thicker than it is in theory, not only because of the voluminous structure in this part of the yarn tail, but also because it may be affected by the quality of the fibre feeding into the yarn tail through the outlet of the transport channel.

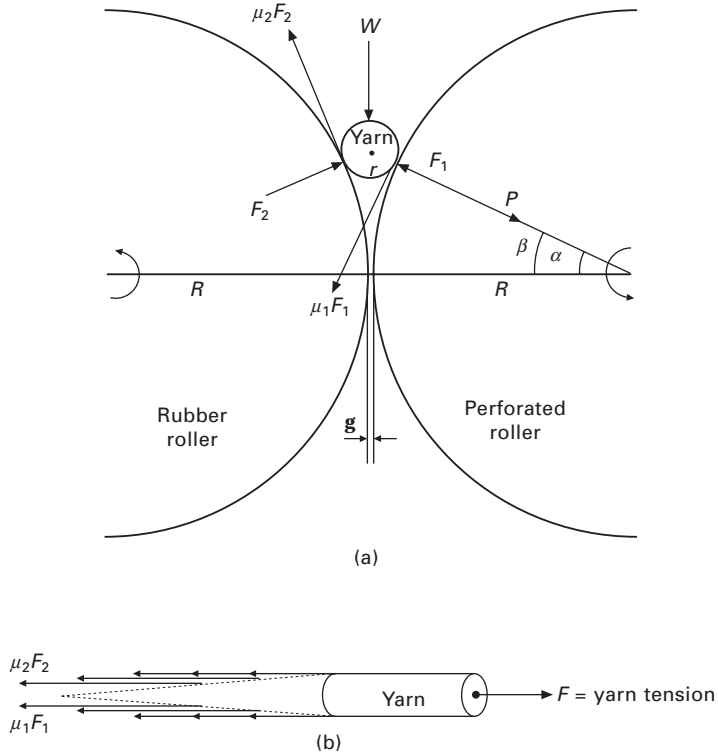

11.10 (a) Diagram of forces acting on yarn in the yarn forming zone; (b) diagram of yarn tension in the yarn forming zone (Merati *et al.*, 1997) ( $\alpha$  = angle of suction slit,  $\beta$  = angle of  $F_1$  and  $F_2$ ,  $\mu_1$  = dynamic coefficient of friction between the perforated roller and the yarn,  $\mu_2$  = dynamic coefficient of friction between the rubber roller and the yarn,  $r$  = yarn radius,  $R$  = perforated roller and rubber roller radii,  $W$  = yarn weight,  $F$  = yarn tension in spinning,  $P$  = forces acting on the yarn by suction air pressure,  $g$  = gap between the perforated roller and rubber roller).

### 11.3 Composite yarn spinning on friction spinning

Whether fibres are embedded in the core or in the sheath of friction-spun yarn depends on whether they are fed to the left or more to the right (in the direction towards yarn take-off). It is thus possible to spin a bicomponent yarn with one yarn constituent forming the yarn core while another is utilized as a sheath and forms the outer regions of the yarn. An additional axial filament feed may be placed along the centre axis of the yarn during its formation. All types of mono- or multifilaments can be used as a core, as well as staple yarns, threads, tape wires or elastomers. With a core yarn composed of staple fibres in the sheath and filament, the latter would mainly provide the

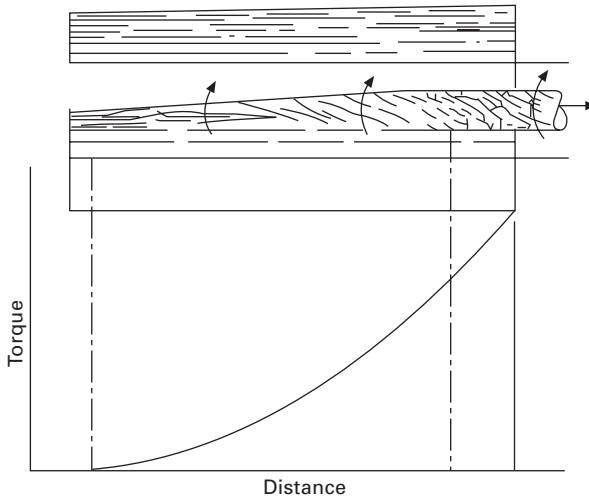

11.11 Torque distribution along the yarn tail (Lord *et al.*, 1987).

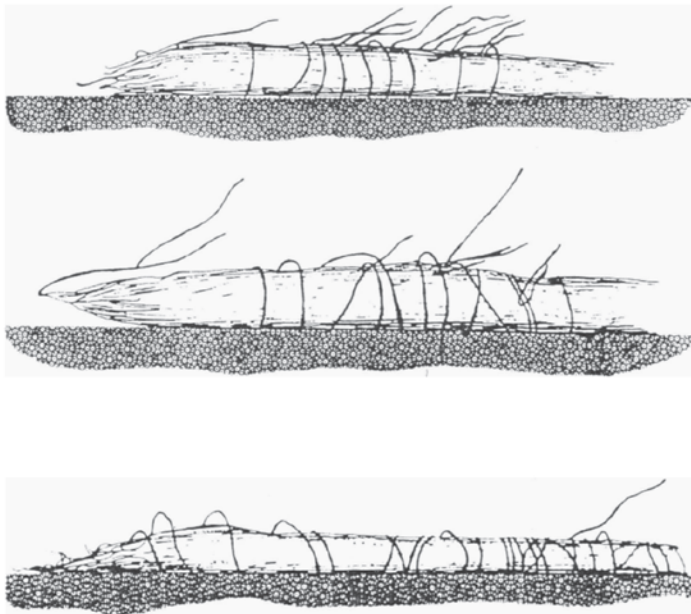

11.12 Sketches of the yarn tail during OE friction spinning (Lord and Rust, 1991a,b).

strength and other functional characteristics, while the sheath provides the traditional spun look (i.e. the visible twisted fibres), feel and comfort of cotton. Merati and Okamura (2005a) modified the feeding part of a prototype friction-spinning machine and then produced two-component yarns such as

core yarn and blend yarn (Fig. 11.13). They produced core yarns such that one component was retained in the yarn core and completely covered by the other (Fig. 11.13(a)). The appearance of the yarn produced is approximately 100% of the sheath component. They have also produced blended yarns from

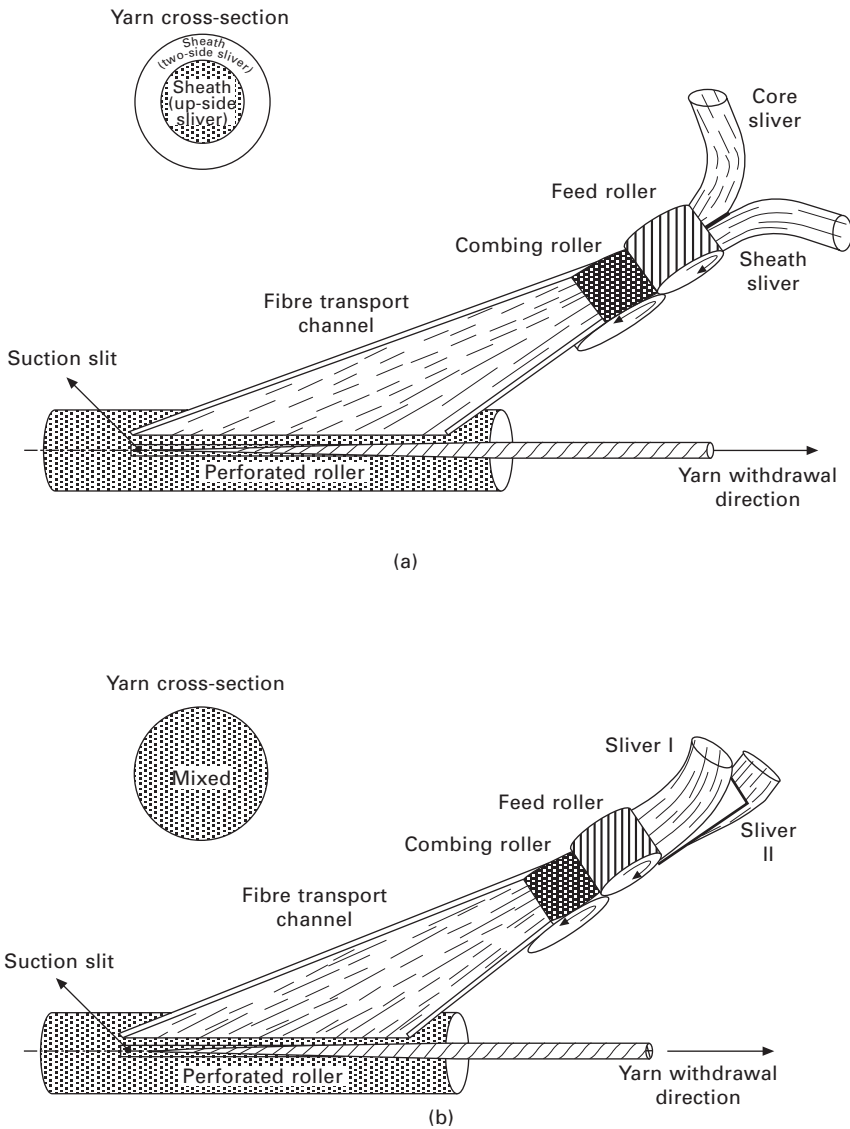

11.13 Diagram of yarn forming zone of a modified friction-spinning machine: (a) side-by side feeding (core yarn); (b) piled-up feeding (blend yarn) (Merati and Okamura, 2005a).

single-component slivers in such a manner that the fibres of two components are uniformly distributed in the yarn cross-section (Fig. 11.13(b)).

In other work, Merati and Okamura (2005a) have produced cotton/recycled fibre (RF), two-component, friction-spun yarns having the RF in the yarn core completely covered by the cotton fibres. These yarns had the appearance of 100% cotton friction-spun yarns (Fig. 11.14). To improve the tensile properties of the RF based yarns, they introduced a filament within the core, the RF forming the middle layer and cotton the remaining fibre sheath (Fig. 11.15). With this method, a novel yarn structure can be produced by using water soluble PVA fibres as a component in the yarn core in either its staple form or its filament form (Merati and Okamura, 2000b, 2001; Ryu *et al.*, 2000). The yarn structure produced with this method is converted into a hollow core yarn by extracting the PVA component from the yarn structure after weaving; air then replaces the extracted PVA fibres. The yarn is now 'hollow' because of the empty space at its centre. The increased entrapped air in the yarn reduces thermal conductivity, making the yarn feel softer, 'warmer' of hand, and bulkier.

#### 11.4 Types of fibres used

The friction-spinning system offers greater flexibility for processing a wide range of fibres (Gsteu, 1986a,b,c). The fibre types used can be categorized into two groups. Group I are the core components of core–sheath yarns, and Group II are those used in conventional yarns and as sheath components of core–sheath yarns. In Group I, both staple fibres and filaments can be used in the core of core–sheath yarns. Staple man-made fibres such as PES, PA, PAN, PP, PVC, viscose, etc. in the range of 1.7–17 dtex and 10–120 mm

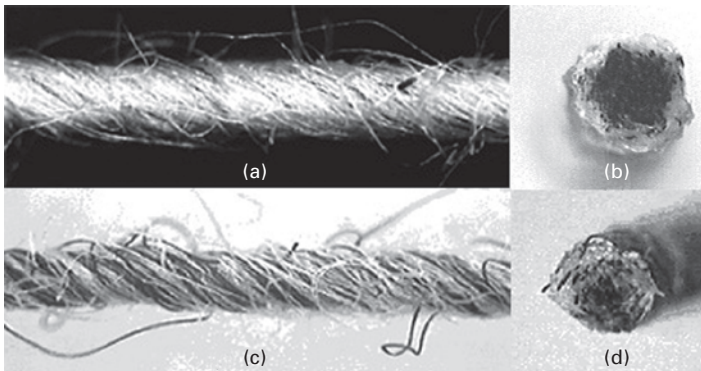

11.14 Photographs of two-component friction-spun yarns: (a) core yarn surface; (b) core yarn cross-section; (c) blend yarn surface; (d) blend yarn cross-section (Merati and Okamura, 2005a).

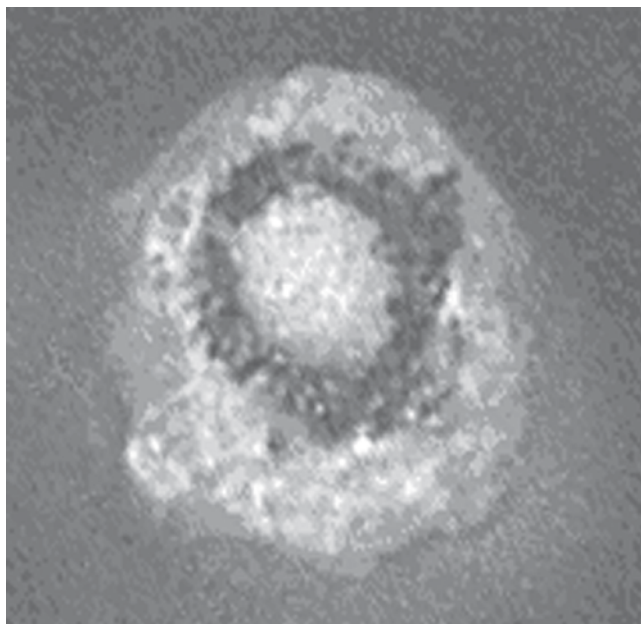

11.15 Photograph of three-component core yarn cross-section (Merati and Okamura, 2005a).

staple length, cotton, either in pure form or in blends with man-made fibres, performance fibres (aramid, polyimide, flame-resistant, and peroxidized fibres), and all other kinds of fibres, either 100% or in blends, can be placed in the core. Monofilaments and multifilaments such as high-tenacity filaments, textured filaments, conventional polymeric filaments, glass, carbon and elastomeric filaments, and metallic wires (steel, brass, copper, etc.) can also be used in the core of core–sheath yarns.

In Group II, general staple man-made fibres (PES, PA, PAC, viscose, etc.), performance fibres (Kevlar, Nomex, Apyeil, Arenka, Kermel, Karvin, Konex, PVC, and carbon fibres), all types of natural fibres (either 100% or in blends with cotton and synthetic fibres), animal fibres (wool and mohair or horsehair in blends with other fibres), and all types of waste fibres (cotton, wool, and regenerated fibres) can be used in conventional yarns as well as in the sheath components of core–sheath yarns in DREF-3 spinning.

In DREF-2000, the natural, man-made, special fibres can be spun: examples of such fibres are para-aramids, polyimids, phenolic fibres, glass fibres, etc., secondary and regenerated fibres and their blends with denier of 1.7–10 dtex fineness and staple lengths of 10–120 mm.

In DREF-3000, man-made fibres such as PES, PA, PAC, PVC, PP, viscose, para-aramids, etc. of length 32–60 mm, and cotton with filament or in blends with man-made fibres can be used in the core of the yarn. In the sheath of

the yarn, man-made fibres and special fibres as indicated for the core, 100% carded cotton, substandard and regenerated wool, wool-blend, natural fibres and their blends can be used.

According to the machine manufacturer's recommendation, drawn slivers of 2.5–3.5 ktex should give better spinning performance. However, slivers finer than 2.5 ktex can be used to spin finer yarns (<42 tex) and coarser slivers of 3.5–4.0 ktex to spin very coarse yarns.

## 11.5 Friction-spun yarn structure and properties

### 11.5.1 Yarn structure

The internal structure of a friction-spun yarn differs from that of ring-spun or rotor-spun yarn. It is characterized by its inferior fibre orientation, buckled and folded fibre configurations, and loose packing of the fibres in the cross-section, associated with low tension during yarn formation (Figs 11.16 and 11.17). The degree of fibre orientation and extension is so low that fibres 40 mm long can be found in sections 10 mm long (Lünenschloss and Brockmanns, 1982). Similar observations have been made by other researchers (Ibrahim, 1995a). Konda *et al.* (1996a) and Merati (1999) have reported a maximum 56% fibre extent in yarns spun on a prototype friction-spinning machine (Figs 11.18 and 11.19). The configuration of fibres is controlled by air flow characteristics inside the transport channel and by the landing behaviour of fibres on the friction rollers (Konda *et al.*, 1996a; Merati, 1999; Ishtiaque *et al.*, 2007).

In the friction spinning system, a fibre is not fed to the yarn tail at the same position along the tail length. Therefore some parts of a fibre appear at the yarn surface and other parts closer to the yarn centre. The fibres are fed to the yarn tail without tension and lie along the yarn tail at necessarily different radial positions. Therefore, they will have different radial positions, i.e. their radial positions increase along the yarn take-up direction, exhibiting a conical layer type of structure. Since the fibres are applied without the required cyclic differentials in tension, they show a different type of migration from that present in ring-spun yarns (Hearle *et al.*, 1965). The migration parameters in friction-spun yarns are mainly influenced by suction air pressure followed by opening roller speed and the difference in friction roller speed for both open-end and core–sheath friction yarns (Ishtiaque *et al.*, 2006a).

Rust and Lord (1991) found that, when a fibre was being wrapped about the core with a constant yarn axial velocity and constant rotational speed, the pitch was constant, but the fibre helix angle increased as a function of the radial position. In fact, because the diameter of the yarn tail along the yarn axis varied in the yarn forming zone, each point of the yarn tail turned with a different rotational speed, which was faster at the tip of the yarn tail.

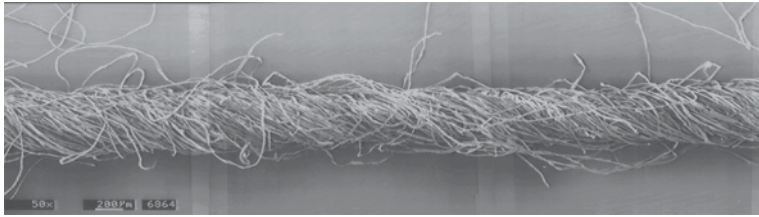

(a)

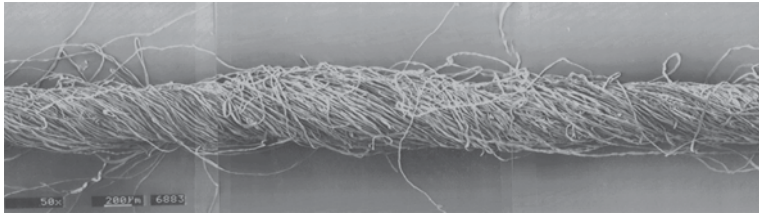

(b)

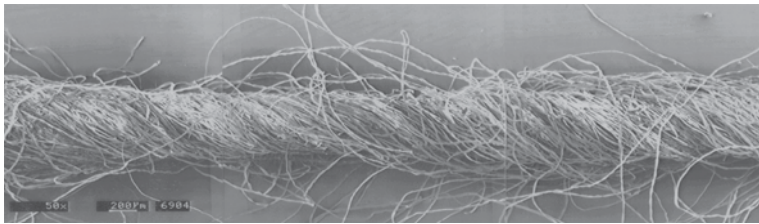

(c)

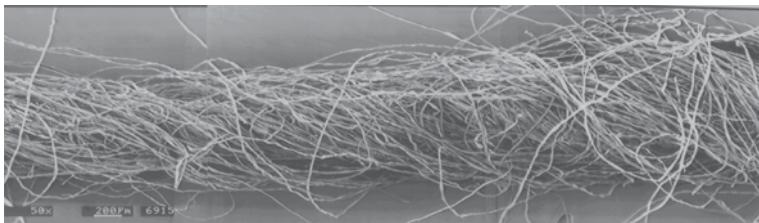

(d)

11.16 SEM photographs of friction-spun yarns of various suction air pressures: (a) 2000 mmAq; (b) 1000 mmAq; (c) 500 mmAq; (d) 200 mmAq.

Thus, a differential twist distribution between the inner and outer layers tended to form. Experimental results by Kato *et al.* (1999) showed that the twists of inner and outer layers of yarn are different, the twist of the inner layers being 2–2.5 times greater than the twist of the surface layer.

The structure of a friction-spun core–sheath yarn differs from that of conventional friction-spun yarns. DREF-3 friction-spun yarns have distinct core and sheath components and therefore exhibit a complex twist structure (Merati *et al.*, 1998a; Ishtiaque and Agrawal, 2000; Gowda *et al.*, 2002a,b

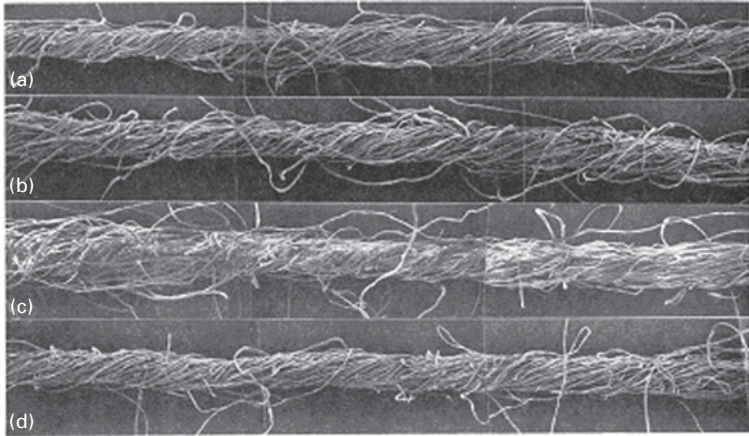

11.17 SEM photographs of friction-spun yarns of various production speeds: (a) 100m/min; (b) 300m/min; (c) 500m/min; (d) ring yarn (Kato, 2004).

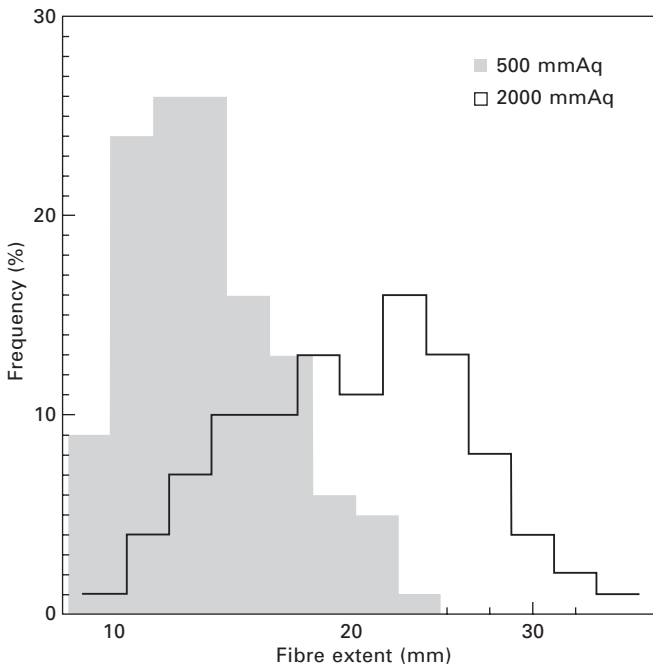

11.18 Histogram of fibre extent in friction-spun yarns at suction air pressures of 500 and 2000 mmAq (acrylic fibres as tracer, 3 den  $\times$  40 mm) (Konda *et al.*, 1996a).

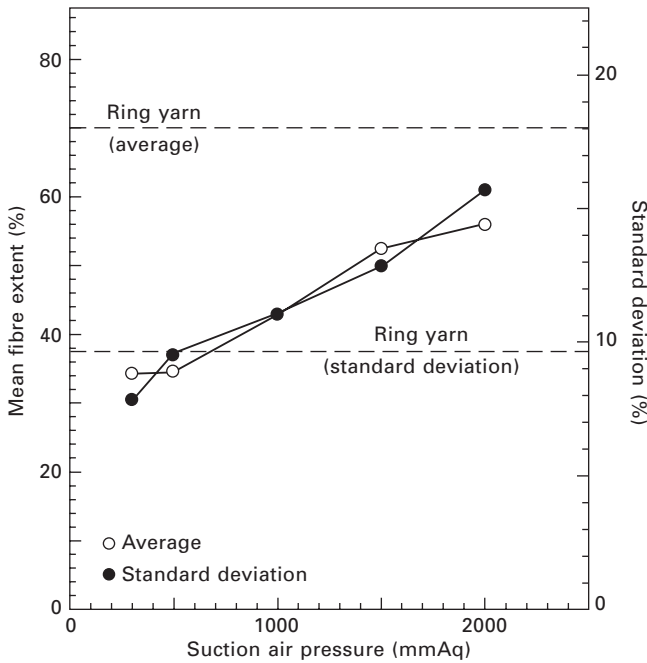

11.19 Fibre extent in friction-spun yarns at various suction air pressures (acrylic fibres as tracer, 3 den ¥ 40 mm) (Konda *et al.*, 1996a).

Salhotra *et al.*, 2003). The core fibres have a low level of twist (Ishtiaque *et al.*, 2005) but the packing density is a maximum at the core and decreases toward the surface (Tyagi *et al.*, 2000). The core may be a filament or a bundle of staple fibres, which is false-twisted, but some twist can remain trapped in it.

Merati *et al.* (1998a) analysed the false-twist distribution in the continuous-filament core of a friction-spun yarn. It was found that, although theoretically the twist imparted to the continuous-filament core is zero, there was some twist present in the filament in both S and Z directions in a short yarn length (Fig. 11.20). As the yarn length increased, these twists tended to combine and cancel each other. The authors added that the remaining false twist in the continuous-filament core in non-pre-tensioned filaments was greater than that in pre-tensioned filaments. Gowda *et al.* (2002b) indicated that the core, in staple-fibre-core DREF-3 friction-spun yarns, exhibits twist in both Z and S directions.

On the basis of an analysis of core twist in core yarn spinning carried out by Merati *et al.* (1998a), the remaining twist in a core filament element in the yarn of length  $V_y \Delta t$  ( $T_{cr}$ ) during the time interval  $\Delta t$  is

$$T_{cr} = (T_y + \mathbf{DT}_y)V_y \mathbf{Dt} - T_c V_y \mathbf{Dt} = V_y \mathbf{DT}_y \mathbf{Dt} \tag{11.3}$$

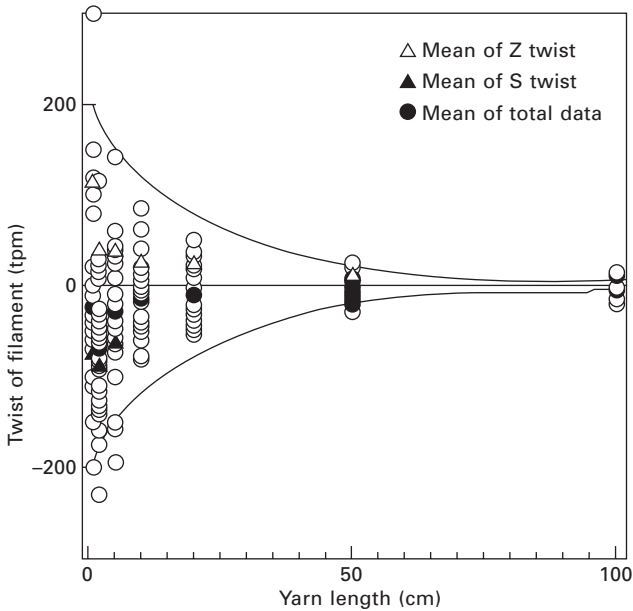

11.20 False-twist of the filament in core yarn friction spinning (Merati *et al.* 1998a) (number of filaments = 2, filament pre-tension = 10 gf per filament).

where  $T_y$  and  $T_y + \mathbf{D}T_y$  are the number of twists in the yarn at time  $t$  and after time interval  $\mathbf{D}t$ , respectively,  $T_c$  is the twist in the core at the pre-spinning zone at time  $t$ , and  $V_y$  is the yarn delivery speed. Notice that the change of the core filament twist direction is momentarily in which S and Z twists cannot combine with each other to make a balance twist structure, because the sheath has captured the core filament.

### 11.5.2 Spinning performance and yarn properties

The spinning performance and yarn quality in friction spinning are influenced by a number of parameters such as machine parameters (opening roller, transport channel, and suction slot), process parameters (speed of the friction rollers, spinning speed, friction ratio, suction air pressure, core–sheath ratio, yarn linear density, and spinning tension), and fibre parameters (fibre friction, fibre strength, fibre fineness, fibre length, and fibre cross-section).

#### *Machine parameters and yarn properties*

The influences of machine parameters such as opening roller, transport channel and friction roller parameters have been studied by several researchers

(Fehrer, 1987; Rust and Lord, 1991; Fuchs, 1982; Zhu *et al.*, 1993; Konda *et al.*, 1996a; Kato, 2004). The opening-roller parameters in terms of its speed and clothing characteristics, such as the form of its teeth, working angle, number of teeth per unit area, and surface finish of the teeth, have a significant influence on the extent of fibre-opening. The fibre-opening effect varies considerably, depending on the machine type (DREF-2 or DREF-3) and the fibres used. In the DREF-3 spinning system, the opening-roller assembly consists of a pair of sawtooth-covered opening rollers instead of a single roller, and these are made to rotate at a very high speed of 12,000 rev/min (Fuchs, 1982). The use of two opening rollers increases the degree of fibre-opening, besides ensuring proper deposition in the spinning nip. The risk of fibre damage is stated to be lower in this arrangement, with hardly any carding or combing effect (Fehrer, 1987).

The shape and design of the transport channel, its position relative to the friction rollers, and its angle of inclination with the direction of yarn withdrawal are the most important parameters affecting fibre-feeding to the yarn forming zone and the quality of friction-spun yarns (Rust and Lord, 1991; Zhu *et al.*, 1993). Zhu *et al.* (1993) observed that, at a low landing angle of  $15^\circ$ , the fibre simply folds into a loop very quickly, whereas at large angles of  $90^\circ$  it tends to be severely crimped. Rust and Lord (1991) reported that a  $30^\circ$  angle produces the strongest yarn, and an increase in the angle of inclination shows a decrease in yarn strength and fibre extent. In the transport channel, the flow speed decreases from inlet to outlet and is mainly influenced by the opening roller speed followed by suction air pressure (Konda *et al.*, 1996b; Ishtiaque *et al.*, 2006a,b). Merati and Okamura (2000a) studied the influence of a convergent transport channel on the structure and properties of OE friction-spun yarns and compared it with that of the traditional (divergent) transport channel. It was observed that the position of the convergent transport channel relative to the suction slit was an important factor in improving yarn properties. The authors reported that the strength of the yarn spun by the convergent channel was about 22% higher, with no significant change in elongation, than that of the yarn made by a conventional channel at a suction air pressure of 2000 mmAq of water. It was noted that the total fibre extent in the yarns spun by the convergent channel was about 54.1%, compared with about 48.6% for conventional-channel yarns (Fig. 11.21).

Readjustment of the position of the suction slot inside the friction roller causes significant changes in the sleeve diameter as well as in the yarn tension owing to changes in the force of the air flow acting on the fibre assembly (Stalder and Soliman, 1989). If the lower edge of the suction slot is above the normal position (the connecting plane of the friction rollers axes), the air stream has a greater tendency to bypass the yarn tail and flow directly towards the perforated roller, thus reducing the yarn tension. On the other

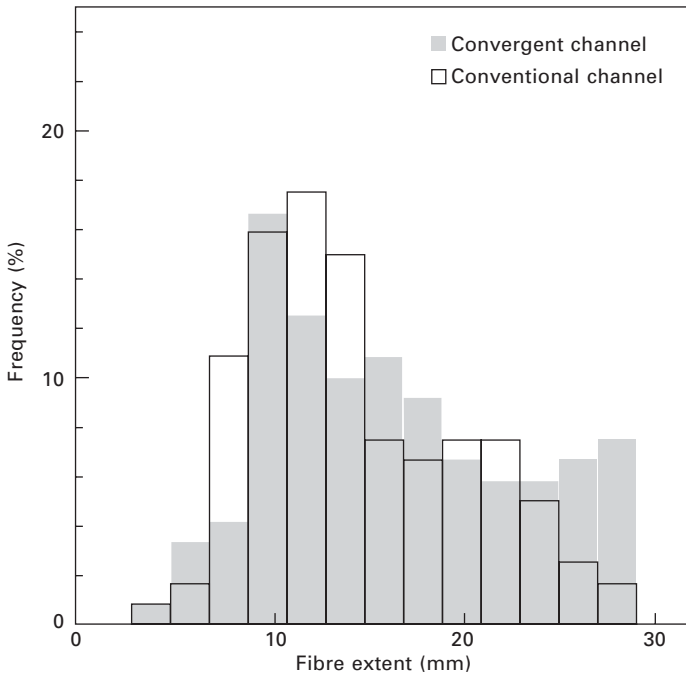

11.21 Histogram of fibre extent (nylon fibres as tracer, 3 den ¥ 30 mm) (Merati and Okamura, 2000a).

hand, if the lower edge of the suction slot is set below the level of the yarn tail, more air will pass through the tail, which causes an increase in yarn tension, leading to greater yarn compactness and strength. The diameter of the fibre sleeve has also been reported to increase with a greater separation of the slot from its normal position, resulting in less yarn twist.

#### *Process parameters and yarn properties*

The process parameters, such as opening roller speed, friction roller speed, yarn delivery speed, friction ratio, suction air pressure, core–sheath ratio, yarn linear density, and spinning tension affect the quality of friction-spun yarns. Researches into the optimization of these parameters to obtain high quality yarns have been widely published (Saad and Sherouf, 1989; Padmanabhan and Ramakrishnan, 1993; Dhamija *et al.*, 2000; Das *et al.*, 2007; Ishtiaque *et al.*, 2005, 2006a,b, 2007; Merati, 1999; Kato, 2004).

It is reported that tenacity and elongation at break of yarns increase and the irregularity of yarn decreases with increasing opening roller speed (Saad and Sherouf, 1989; Dhamija *et al.*, 2000; Kato, 2004). More specifically,

the yarn strength increases with increasing opening roller speed, reaches a maximum, and then decreases with further increases in the roller speed.

The friction roller speed directly influences the yarn twist (Ulku *et al.*, 1995). At higher speeds, the twist is expected to be greater (Dhamija *et al.*, 2000; Kato, 2004). However, there is some slippage between the surface of the friction rollers and that of the yarn in which the yarn twist could not be calculated by the ratio of diameters of friction rollers and that of yarn. Above a certain speed limit, the frictional forces between the friction rollers and the fibre assembly are not sufficient to overcome the torsion forces in the yarn, resulting in greater slippage between the two. Kato (2004) found that an increase in the speed of the friction rollers from 4000 to 8000 rev/min increases the yarn twist and strength but reduces the yarn U% (Fig. 11.22).

It has been reported that spinning speed influences the strength of OE friction-spun yarns. Brockmanns and Lünenschloss (1984a,b) reported poor mass irregularity for finer yarns spun at high production speeds. The tenacity of yarn decreases with an increase in the production speed, and the breaking elongation decreases with an increase in the spinning speed until a certain speed and thereafter increases (Padmanabhan and Ramakrishnan, 1993; Ishtiaque and Swaroopa, 1998; Alagha *et al.*, 1994; Kato, 2004) (Fig. 11.23).

The ratio of the friction roller surface speed to the spinning speed is defined as the friction ratio. The friction ratio plays a great rule in twisting the fibres into a yarn, because the twist insertion mechanism is based on friction between the surfaces of the friction rollers and that of the yarn and increases with an increase in the friction ratio (Stalder and Soliman, 1989). Chattopadhyay *et al.* (1998) observed that, for DREF-2 yarns, the tenacity and extension first increased with the initial increase in the friction ratio, reached a maximum, and thereafter decreased with a further increase in the friction ratio. However, for DREF-3 yarns, it was found that the tenacity, extension, and twist increased for an increase in the friction ratio up to 2.8 and thereafter remained almost constant for a further increase in the friction ratio. An increase in the friction ratio from 3.2 to 5.1 significantly increases the packing density of DREF-3 yarns (Tyagi *et al.*, 2000).

Suction air pressure in the yarn forming zone is provided to hold the fibres to the surface of the friction rollers while they are transferred via the channel to the yarn forming zone. This leads to an increased amount of torque acting on the yarn tail (Konda *et al.*, 1996a,b; Merati *et al.*, 1997). As a result, the yarn tension and twisting efficiency were found to increase with increasing air suction pressure. Ibrahim (1995b) reported that there is probably a maximum air suction pressure at which yarns are hard-twisted but that above this pressure the number of twists per metre would be reduced. Konda *et al.* (1996a) reported that increasing the air suction pressure

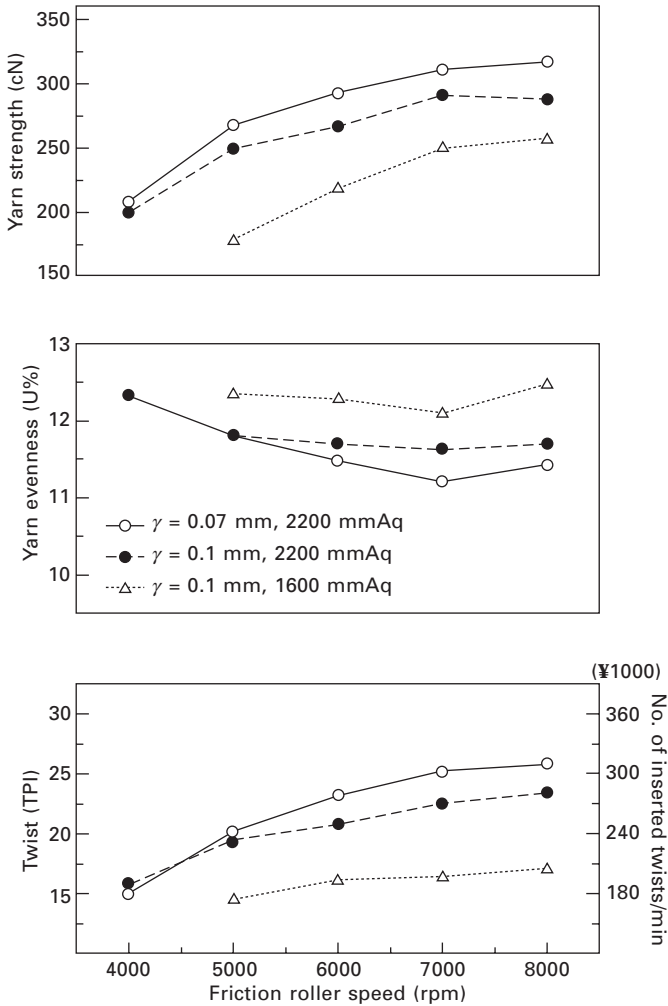

11.22 Effect of friction roller speed on yarn properties at spinning speed of 300 m/min, ( $g$  = gap between the friction rollers) (Kato, 2004).

increases the air and mean fibre speeds in the fibre transport channel. They reported that the air and fibre speed decrease along the channel length. An increased mean fibre speed along the transport channel helps to maintain the orientation of the fibres inside the channel and prevent them from buckling, thus improving the yarn appearance and fibre extent in the yarn. Among the yarn properties, yarn diameter, unevenness and elongation have been reported (Konda *et al.*, 1996b) to decrease with an increase in air suction pressure, whereas the yarn tenacity has been shown to increase (Fig. 11.24). They also

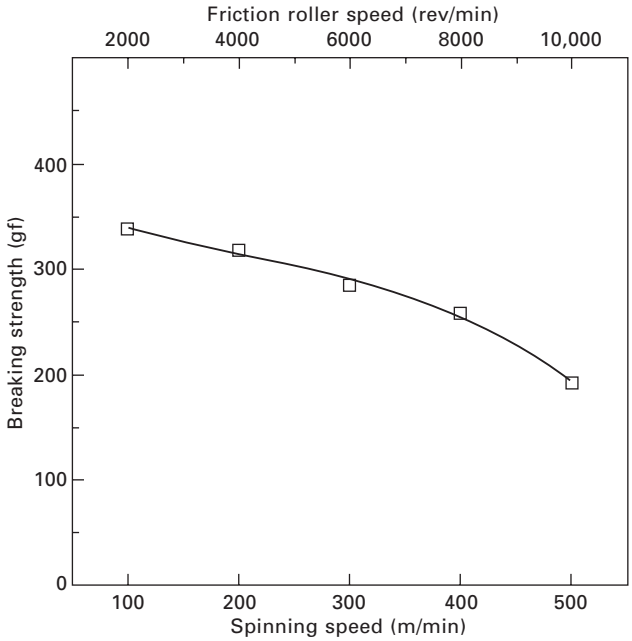

11.23 Effect of spinning speed on breaking strength (Kato, 2004).

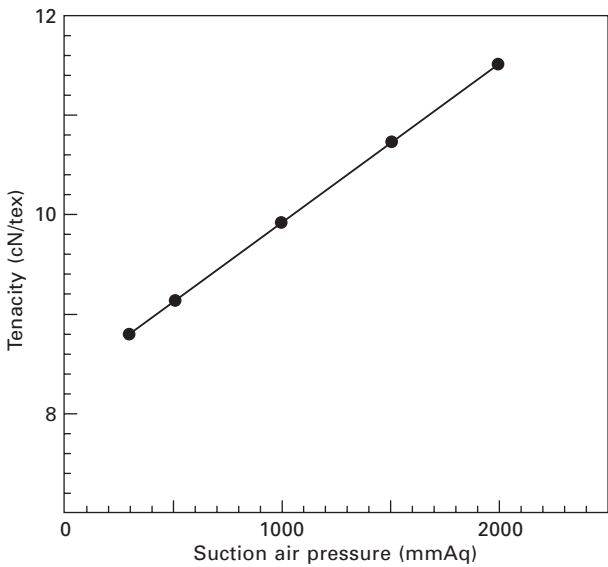

11.24 Effect of suction air pressure on yarn strength (Konda *et al.*, 1996a).

indicated that the twist efficiency increases from 7.7% to 9.9% as the air suction pressure increases from 300 to 2000 mmAq (Fig. 11.25). A decrease in air suction pressure increased the strength variability as well as the mass variability as measured by the Uster Evenness Tester, resulting in a weaker and more irregular yarn (Louis *et al.*, 1985). The air suction pressure also has a significant influence on yarn hairiness (Das *et al.*, 2007).

The core–sheath ratio has considerable influence on the characteristics of friction-spun yarns. Generally, an increase in sheath proportion increases the core coverage by the sheath and decreases the problem of sheath slippage over the core surface during abrasion. The critical core–sheath ratio depends on the fibre length, fineness, type and filament core surface structure (Thierron and Hunter, 1984). In DREF-3 core–sheath yarns, some yarn properties, such as tenacity, breaking extension, abrasion resistance and unevenness, increase with an increase in sheath fibres up to 40% (Tyagi *et al.*, 1995). However, when polyester fibre is used as the core, increases in core component from 45% to 65% cause increases in the yarn strength and elongation (Thierron and Hunter, 1984; Chattopadhyay and Sinha, 2008). For 100% polyester fibres of 44 mm and 1.33 dtex, it was observed that an increase in core content increased the packing density of the DREF-3 yarn (Tyagi *et al.*, 1995).

In friction spinning, the effective surface contact of the yarn with the friction rollers decreases as the yarn thickness decreases, resulting in less torque generation and twist efficiency. When the yarn diameter is less than

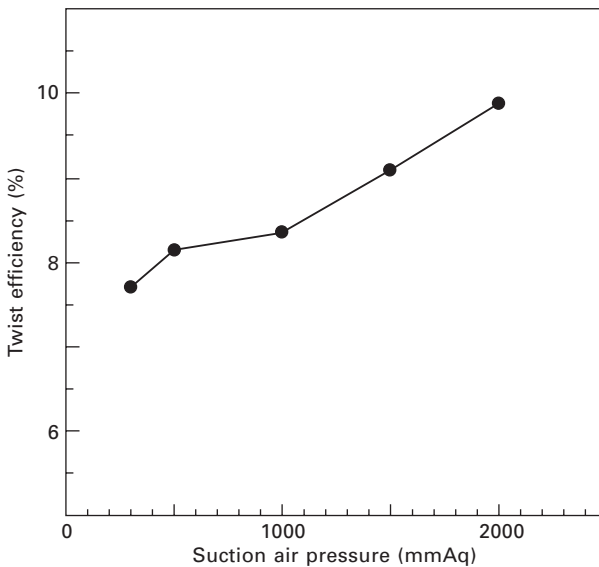

11.25 Effect of suction air pressure on twist efficiency (Konda *et al.*, 1996a).

the gap between the friction rollers, it is not in complete contact with both friction rollers, and is not firmly held to the perforated roller or the suction slit, resulting in low spinning tension and an unstable spinning process (Merati *et al.*, 1997). The strength and elongation for finer friction-spun yarns are lower as a result of less torque generation owing to reduced contact surface with the friction rollers (Brockmanns and Lünenschloss, 1984a,b; Padmanabhan and Ramakrishnan, 1993; Thierron and Hunter, 1984). Finer yarns spun at higher speeds also display poor mass regularity and more imperfections. A significant reduction in twist efficiency of 37- and 32-tex yarns was observed by Merati *et al.* (1997) as compared with yarns in the linear-density range of 47–85 tex (Fig. 11.26). They concluded that because of the low spinning tension of fine yarns, it is difficult to produce them by friction spinning (Fig. 11.27).

In friction spinning, the spinning tension has been reported to be relatively low and cannot be increased as easily as in other spinning systems (Lünenschloss and Brockmanns, 1985). A lower tension is advantageous in terms of a low end-breakage rate but, because of insufficient friction between the fibres, the lower spinning tension results in lower yarn strengths. Merati *et al.* (1997) considered the air suction pressure in the suction slit and the

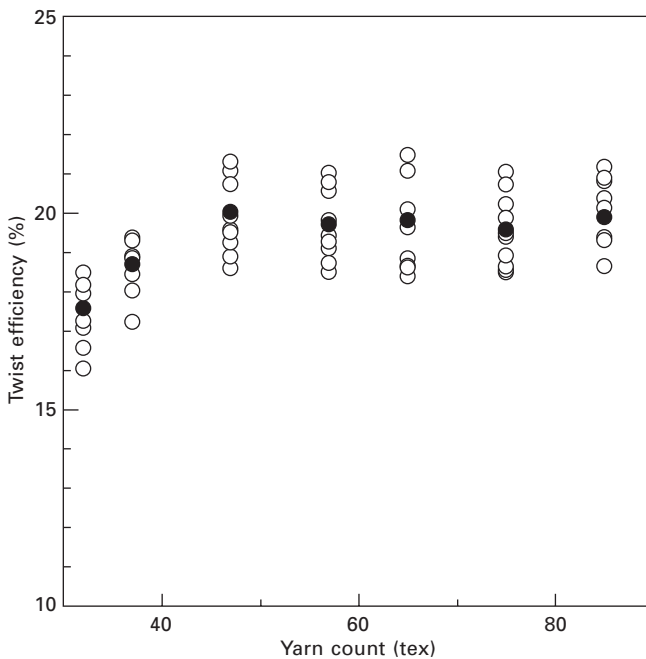

11.26 Twist efficiency of various yarn counts (suction air pressure = 1000 mmAq) (Merati, 1999).

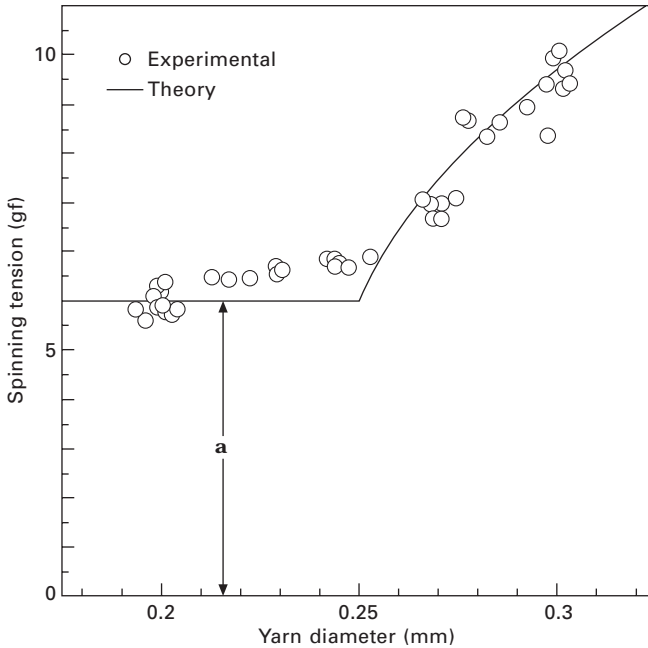

11.27 Relationship between yarn tension and yarn diameter (suction air pressure = 1000 mmAq); 'Theory' indicates calculation +  $\alpha$  (Merati, 1999).

yarn size to be the most important parameters affecting the spinning tension. In their studies, mathematical expressions were derived for the spinning tension and verified experimentally. It was shown that the spinning tension increases with increasing air suction pressure and yarn size (Figs 11.27 and 11.28). In the spinning of filament-core yarn, tension was seen to be influenced by the filament pre-tension (Merati *et al.*, 1998b). Yarn tension increases with the incorporation of filament pre-tension. The pre-tension was also observed to influence the configuration of the filament in the core and other structural as well as mechanical properties of the spun yarns. It was shown that, at a low level of pre-tension, the filament did not follow a straight path and made a helix angle along the yarn axis. It also developed a more intimate interface with the sheath fibres and was expected to enhance the sheath-slipping resistance of the sheath along the filament core during abrasion (Miao *et al.*, 1996).

#### *Fibre parameters and yarn properties*

The twist efficiency in friction spinning is largely dependent on the friction between the surface of the friction rollers and the fibres being spun. The

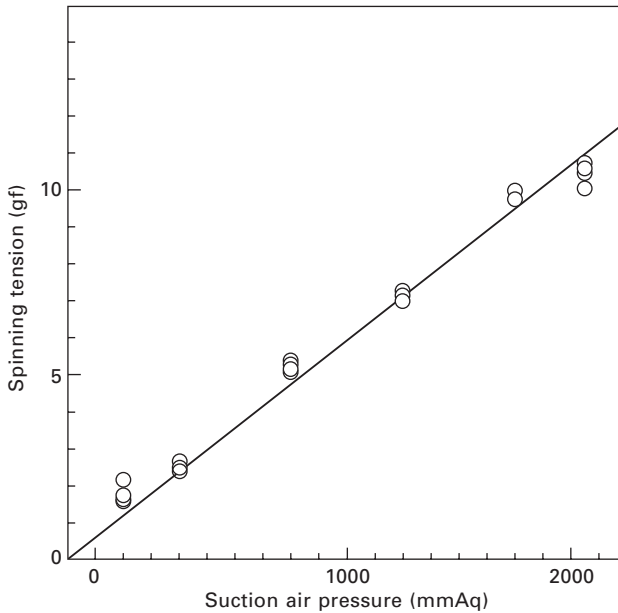

11.28 Relationship between yarn tension and suction air pressure (yarn count = 85 tex) (Merati, 1999).

inter-fibre friction should also be high, since the parallel-fibre core needs to be properly bound to resist slippage. It is therefore desirable to have high fibre-to-fibre and fibre-to-metal friction for friction spinning (Salhotra, 1992; Gowda *et al.*, 2002a,b).

The fibre-strength translation efficiency is very low in friction-spun yarns. However, the inherent weakness of friction-spun yarns can be partly overcome through the use of high-tenacity fibres (Salhotra, 1992). Louis *et al.* (1985) reported that about 74% of the skein strength of DREF-3 yarn can be accounted for by fibre length, strength, elongation, and micronaire value of cotton fibres, as against 94% and 92%, respectively, in ring- and rotor-spun yarns. However, an increase in fibre strength causes a greater increase in yarn strength than a corresponding increase in fibre length.

The minimum number of fibres required in friction-spun yarns is higher than in other spinning systems, and finer fibres should therefore be used for a finer range of counts. Nierhaus (1986) recommended 90–100 fibres for 100% polyester fibre, 100–110 fibres for polyester-fibre/cotton blends in a 50/50 blend, and 100–120 fibres for 100% cotton in the yarn cross-section. However, the machine manufacturer recommends a higher limit for the minimum number of fibres in the DREF-3 yarn cross-section, i.e. 150 fibres to avoid frequent end-breaks, irrespective of the fibre type. It has also been

shown that finer fibres produce stronger, more extensible and more uniform yarn with fewer imperfections.

The fibre-length requirement in friction spinning is similar to that in rotor spinning. Longer fibres are more susceptible to damage, show a tendency to lap around the opening roller, and also exhibit a higher buckling tendency in the spinning zone. Although fibre-length utilization is very poor in friction spinning, longer fibres still produce stronger yarns with higher breaking extension. On the other hand, the use of short-staple fibres can reduce the fibre damage caused by the opening roller and improve the spinning efficiency. With regard to the fibre cross-section, fibres of a ribbon-like cross-section result in a higher degree of yarn twist than those with a circular cross-section.

### 11.5.3 Post-spinning process and yarn properties

It is a well-known fact that singles friction-spun yarns exhibit lower tenacity, a higher snarling tendency, and poorer performance than other yarns during weaving or knitting. It is also known that plying a yarn changes its tenacity and other properties. Lord and Radhakrishnaiah (1987) concluded that, when the friction-spun yarn was plied Z on Z, the tenacity was considerably higher than when it was plied S on Z, and the best tenacity appeared to be obtained at 4.2 TM, at which condition the tenacity was 161% of that of the single yarns. They also found that the CV of tenacity of the plied yarn at 4.2 TM was 8.3% while the CV of single yarn was 10.1%.

### 11.5.4 Friction-spun yarn properties in comparison with other spinning systems

There are many researches concerning the properties of yarns spun by different spinning systems. However, these studies differ in terms of the raw material, spinning conditions, and machine versions used. Generally, friction-spun yarns demonstrate lower tenacity than ring and rotor spun yarns (Lord *et al.*, 1987; Salhotra *et al.*, 2000). They are also inferior in terms of unevenness, imperfections, strength variability, and hairiness. The magnitude of difference between the friction-spun yarn tenacity and that of other spinning systems depends on the raw material, spinning conditions, and machine versions used. Brockmanns and Lünenschloss (1984a,b) compared 203 yarns of a 65/35 polyester-fibre cotton blend spun on four different spinning systems. It was shown that filament wrap spinning produced the strongest yarn, followed by ring, air-jet, rotor, and OE friction spinning in that order. The mass irregularity of air-jet-, ring-, and wrap-spun yarns was comparable, but friction-spun yarns had a higher irregularity, though lower than that of rotor-spun yarns. The imperfections were also less in friction-spun yarns than in rotor-spun yarns but were higher than those in ring- and

air-jet-spun yarns. Further, friction-spun yarns are more hairy than all other yarns and are more susceptible to stripping back and thus abrading easily. The same results were also obtained by other researchers (Louis *et al.*, 1985; Padmanabhan, 1989, 1991). In contrast, Thierron and Hunter (1984) observed that the strength of polyester-fibre/cotton blended DREF-3 yarns, over a range of yarn counts and blend proportions, lay between that of ring-spun yarn and that of rotor-spun yarn.

With regard to yarn hairiness, Barella *et al.* (1989) reported that DREF-3 yarns occupy an intermediate position between ring-spun and rotor-spun yarns as far as short hairs (up to 3 mm) and total hairiness were concerned. For hairs longer than 3 mm, friction-spun yarns are more hairy than ring-spun yarns. Rotor-spun yarns show the lowest value in both respects. In addition, DREF-3 yarns are the most irregular in terms of twist and linear-density unevenness, and ring-spun yarns are the most even. DREF-3 yarns also show a lower resistance to abrasion and repeated extensions than ring- and rotor-spun yarns (Barella and Manich, 1989). Thierron (1985) found that DREF-3 yarns exhibit the highest rigidity. The values of flexural rigidity were from about three to four times those of ring-spun yarns. Further, the twist level did not have any influence on the rigidity of ring- and rotor-spun yarns, but the flexural rigidity of DREF-3 yarn decreased considerably with increasing twist. Moreover, the variation in flexural rigidity of DREF-3 yarns was much higher than that of ring- and rotor-spun yarns. Chattopadhyay and Banerjee (1997) concluded that, with yarn-to-yarn friction, friction-spun yarn gives the highest values, followed by rotor- and ring-spun yarns for cotton and viscose fibres. However, for polyester fibre, rotor-spun yarn shows the highest friction, followed by friction- and ring-spun yarns. In respect of yarn-to-guide friction, ring-spun yarn exhibits the highest friction, followed by rotor- and friction-spun yarns from cotton and viscose fibres. However, with polyester fibre, friction-spun yarn shows the highest value, followed by rotor- and ring-spun yarns.

## 11.6 Advantages and limitations of friction spinning

In general, when compared to other spinning systems, the friction spinning system offers greater flexibility of processing a wide range of fibres, produces coarser yarns, spins yarns at much higher production speeds, stands unique in producing multicomponent yarns and hollow yarns, has the ability to provide higher twisting rates and is amenable to automation. The fundamental advantage of the friction-spinning system lies in its ability to generate a number of turns per unit length of yarn with one revolution of the twisting element (Langer, 1998). Because of its versatility and high speed the friction-spinning machine offers the following additional advantages and possibilities (Salhotra, 1992).

- Friction spinning involves a very low mass rotating for the insertion of yarn twist (Lünenschloss and Brockmanns, 1985), i.e. only the forming yarn rotates at high speed, but all other moving parts rotate at relatively low speeds, which results in a lower energy requirement for twisting. This system therefore has the potential to be more economical than other systems.
- It is evident from the result of researches (Krause, 1985; Balasubramanian, 1992) that, in friction spinning, the forces acting on the fibre assembly are relatively low, which results in a lower tension. The low tension is advantageous in terms of a high production rate and low end-breakage rate. The number of end-breaks in friction spinning is quite low, which results in higher machine efficiency than in ring and rotor spinning. The spinning tension is practically independent of the production speed and hence this spinning system has a good potential for higher production speeds (up to 500 m/min) (Kato, 2004) than will ever be achievable by rotor spinning and other spinning systems. It can spin at very high twist-insertion rates of up to 300,000 rev/min owing to the very low spinning tension.
- The friction-spinning system has higher efficiency and flexibility of processing than ring spinning, with no compromise in yarn quality.
- Rewinding is eliminated.
- The yarns are bulkier than ring-spun and rotor-spun yarns.

There are a number of drawbacks and limitations of friction spinning that are restricting its acceptance as a system for producing general-purpose yarns. It has been well established that singles friction-spun yarns exhibit lower tenacity, a higher snarling tendency, and poorer performance than other yarns during weaving or knitting. Other important drawbacks and limitations are (Salhotra, 1992; *Melliand Textilberichte*, 1988):

- The count range for friction spinning is narrow and limited. The system can spin yarns in the count range of 42–591 tex. However, in practice, only coarser yarns of up to 42 tex are spun.
- The low spinning tension results in insufficient inter-fibre cohesion, which in turn leads to inferior yarn strength as compared with that of ring and rotor yarns.
- The extent of disorientation and buckling is greater with longer and finer fibres.
- The requirement of a higher number of fibres in the yarn cross-section limits the fineness of yarns.
- There is an increase in yarn unevenness and imperfections as the production speed increases.
- There is difficulty in holding spinning conditions constant.
- The air consumption of the system is high.

Although the yarns can be produced at production speeds of up to 500 m/min by a prototype friction-spinning machine (Kato's thesis), the production speed is limited by the drafting system and fibre-transport system.

## 11.7 Application of friction-spun yarns

Friction spinning has found its applications mainly in the coarse-count sector. The applications of friction-spun yarns can therefore be classified into two categories such as general applications and technical applications. The feeding of various types of core and complete covering of these cores have opened new technical fields of application for friction-spinning technology. Apart from the commonly used natural and man-made fibres, the ease of processing speciality fibres on DREF systems has made it possible to create a variety of yarns useful for industrial, technical, and speciality products (Gsteu, 1982, 1985, 1986a,b,c; Fehrer, 1991, 1994).

DREF-2 yarns in the coarse-count range of 100–1000 tex have been extensively used for various household and technical applications such as blankets of all types, cleaning rags and mops from cotton waste and other waste fibres, fancy yarns for interior decoration and domestic textiles, filler yarns for carpets, shoes, ropes and cables, filter cartridges for liquid filtration, leisurewear, pullovers, suits and outerwear fabrics, secondary backings for tufted carpets, upholstery, tablecloths, wall coverings, curtains, hand-made carpets, bed coverings and other decorative fabrics, heavy protective industrial fabrics, such as heavy flame-retardant fabrics, conveyor belts, clutch and brake linings, friction linings for the automobile industry, packing materials, gaskets and other asbestos substitutes, recycling of selvedge wastes from the weaving sector, aramid-fibre yarns used in fire-protection clothing, bulletproof vests, insulators, etc. (Fig. 11.29).

Various fields of application of DREF-3 yarns are broadly categorized as industrial textiles, transportation and automotive textiles, safety and protective textiles, outdoor textiles, outerwear textiles and domestic textiles (Gsteu, 1986c). In industrial textile fields, DREF friction spinning is ideal



11.29 Some applications of DREF II yarns (Fehrer, 1994).

for the manufacture of non-asbestos yarns for application in heat-, fire- and flame-retardant clothing, friction linings (clutch and brake linings) for the automotive industry, gaskets, packing materials, insulation tapes, braided tubing, cables, wires and ropes. Applications of DREF-3 yarns in transport include fibre-reinforced plastics in the automotive industry such as bodywork components, mudguards, side doors, trunk (boot) lids and crash absorbers, high-tenacity core yarns made from ultraviolet-resistant PES-fibre filament for canvas fabrics for military tents, truck covers, tarpaulins, sacks, bags, belts, conveyor belts, fire blockers, seat covers for buses, trains and other transport facilities. Applications in safety and protective areas include heavy protective garments, industrial gloves, industrial aprons, heatproof gloves, shoe covers, safety clothing, protective garments with super-strength filaments covered by aramid fibres for soft and hard ballistic areas, and protective garments for military and fire fighters. Outdoor applications include canvas fabrics for tents, tarpaulins, and awnings and fabrics for covering furniture. Outerwear applications include fabrics for leisurewear and sportswear, e.g. elasticated jeans, corduroy fabrics, and flatwear fabrics produced by the use of elastomeric-fibre filament in the core, covered with a staple-fibre sheath. Domestic applications include basic fabrics for terry towels and other terry fabrics, fancy-yarn curtain fabrics, tablecloths, upholstery fabrics, and other decorative fabrics (Fig. 11.30).

## 11.8 Future trends

Friction spinning has made substantial progress and established itself well in the medium- and coarse-count sector. It has potential for high production speeds and twisting rates. The spinning tension is very low and very high twisting rates are possible without the need to rotate the friction roller at higher speeds. It stands unique in the production of a variety of multicomponent yarns, which are preferred for technical textiles. The system is also more versatile in handling all types of natural and synthetic fibres. Friction-spun

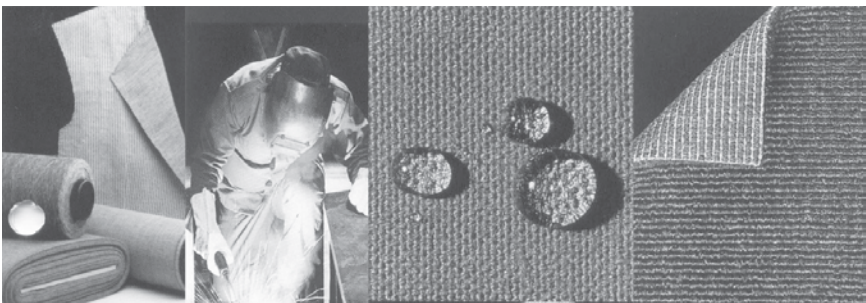

11.30 Some applications of DREF III yarns (Fehrer, 1991).

yarns are not normally used in the manufacture of conventional textiles, though they find some applications, especially as pile yarns, as weft yarns, and in certain knitted goods, where bulk and compressibility are desired. The hollow yarns may provide a new trend for DREF-3 friction-spun yarns.

Friction spinning has reached a plateau with regard to machine design and modifications. The main drawbacks of friction spinning are the lower yarn strength and the inability to spin medium and fine counts. Thus, the technical problem still existing at present is that the individual fibres fed into the spinning nip between the two friction rollers should be – as far as possible – stretched and evenly distributed, in order to be able to produce finer-count yarns with tenacities comparable to those of a rotor-spun yarn. Further developments on friction-spinning machines are clearly focused on optimizing the fibre feed for finer yarn counts. Nevertheless, the current systems offer ample scope to researchers and textile technologists for engineering yarns with desired characteristics through optimization of a wide range of process parameters and the processing of a wide variety of selected raw materials. New developments and modifications are, however, essential in order to further improve friction-spun yarn quality and extend the count range.

## 11.9 References and bibliography

- Alagha M.J., Oxenham W. and Iype C. (1994), 'Influence of production speed on the tenacity and structure of friction spun yarns', *Text. Res. J.*, 64, 185–189.
- Bahera B.K. and Joshi V.K. (2004), 'Weavability of DREF-2 yarns', *Indian J. Fibre Text. Res.*, 29, 400–411.
- Balasubramanian N. (1992), 'Friction spinning – a critical review', *Indian J. Fibre Text. Res.*, 17, 246–251.
- Barella A. and Manich A.M. (1989), 'Friction spun yarns versus ring and rotor spun yarns: Resistance to abrasion on repeated extensions', *Text. Res. J.*, 59, 767–769.
- Barella A., Alvarez Vega P.A. and Castro L. (1989), 'Yarn attrition by abrasion: A comparison of polyester-fibre/cotton blended-fibre yarns spun by different spinning processes', *J. Text. Inst.*, 80, 599–603.
- Brockmanns K.J. and Lünenschloss J. (1984a), 'Friction-spinning analysed', *Int. Text. Bull., Yarn Forming*, 30, No. 2, 5–23.
- Brockmanns K.J. and Lünenschloss J. (1984b), 'Friction-spinning analysed', *Int. Text. Bull., Yarn Forming*, 30, No. 3, 15–32.
- Chattopadhyay R. and Banerjee S. (1997), 'The frictional behaviour of ring-, rotor-, and friction-spun yarn', *J. Text. Inst.*, 88, Part 1, 59–66.
- Chattopadhyay R. and Chakraborty A. (1998), 'Influence of additional twist on tensile behaviour of friction-spun yarns', *Indian J. Fibre Text. Res.*, 23, 223–228.
- Chattopadhyay R. and Chakrabarti A.K. (2003), 'Influence of sheath-core fibre characteristics on the properties of DREF-3 friction yarns', *Indian J. Fibre Text. Res.*, 28, 150–156.
- Chattopadhyay R. and Sinha S.K. (2008), 'Effect of sheath fibre arrangement on the tensile behaviour of DREF-3 polyester cotton yarn', *J. Text. Inst.*, 99, 111–118.

- Chattopadhyay R., Salhotra K.R. and Dhamija S. (1998), 'Influence of friction ratio on quality of friction-spun yarns', *Indian J. Fibre Text. Res.*, 23, 131–135.
- Chattopadhyay R., Salhotra K.R., Dhamija S. and Kaushik R.C.D. (2000), 'Influence of core-sheath ratio and core type on DREF-3 friction-spun core yarns', *Indian J. Fibre Text. Res.*, 25, 256–263.
- Chattopadhyay R., Salhotra K.R., Dhamija S. and Kaushik R.C.D. (2001), 'Core coverage in DREF-3 friction-spun yarns', *Indian J. Fibre Text. Res.*, 26, 387–391.
- Das A., Ishtiaque S.M. and Vishnoi P. (2007), 'Influence of process parameters on properties of open-end and core-sheath friction spun acrylic yarns', *J. Text. Inst.*, 98, 513–521.
- Dhamija S., Tyagi G.K., Salhotra K.R. and Sett S.K. (2000), 'Influence of spin finish and opening roller speed on the characteristics of OE friction-spun acrylic yarns', *Indian J. Fibre Text. Res.*, 25, 169–176.
- Dhamija S., Salhotra K.R., Chattopadhyay R. and Kaushik R.C.D. (2002), 'Effect of friction drum speed and yarn delivery rate combination for a constant friction ratio on quality of friction-spun yarns', *Indian J. Fibre Text. Res.*, 27, 33–37.
- Dhamija S., Sambari S. and Chattopadhyay R. (2004), 'Migratory behaviour of core and sheath fibers in DREF-3 friction-spun acrylic yarns', *Indian J. Fibre Text. Res.*, 29, 290–300.
- Fehrer E. (1987), 'Friction Spinning: The State of the Art', *Text. Month*, Sept., 115–116.
- Fehrer E. (1991), 'The DREF-3 friction spinning machine', *Textilmaschinenfabrik*.
- Fehrer E. (1994), 'The DREF 2/94 friction spinning system', *Textilmaschinenfabrik*.
- Fuchs H. (1982), 'Latest DREF: Medium counts at 300 m/min', *Text. Horiz.*, 2, No. 6, 20–21.
- Gowda R.V.M., Salhotra K.R. and Ishtiaque S.M. (2002a), 'Influence of frictional characteristics of core and sheath on twist structure and tensile properties of DREF-3 friction-spun yarns. Part I: Filament-core DREF-3 friction spun yarns', *J. Text. Inst.*, 93, 137–152.
- Gowda R.V.M., Ishtiaque S.M. and Salhotra K.R. (2002b), 'Influence of frictional characteristics of core and sheath on twist structure and tensile properties of DREF-3 friction-spun yarns. Part II: Staple-core DREF-3 friction spun yarns', *J. Text. Inst.*, 93, 153–161.
- Gsteu M. (1982), 'New products with the DREF-2 spinning system', *Melliand Textilber. (Eng. Edn)*, 11, 319–322.
- Gsteu M. (1985), 'Yarn production from polypropylene fibres for secondary carpet backings as an alternative to jute', *Int. Text. Bull., Yarn Forming*, 31, No. 1, 39–43.
- Gsteu M. (1986a), 'DREF: Progress with products. Part I', *Text. Horiz.*, 6, No. 10, 34–38.
- Gsteu M. (1986b), 'DREF: Progress with products. Part II', *Text. Horiz.*, 6, No. 11, 36–37.
- Gsteu M. (1986c), 'Friction-spinning technology for technical speciality yarns', *Melliand Textilber. (Eng. Edn)*, 15, 176–177.
- Hearle J.W.S., Gupta B.S. and Merchant V.B. (1965), 'Migration of fibres in yarns. Part I: Characterization and idealization of migration behaviour', *Text. Res. J.*, 35, 329–334.
- Ibrahim A.R.B. (1995a), 'Fibre orientation and utilization in polyester open-end friction-spun yarns', *Indian J. Fibre Text. Res.*, 20, 211–213.
- Ibrahim A.R.B. (1995b), 'Effect of back-suction on the twist-tensile strength characteristics of open-end friction-spun cotton yarns', *Indian J. Fibre Text. Res.*, 20, 60–62.

- Ibrahim A.R.B. (2003), 'Cotton and polyester in OE friction spinning', *Textile Asia*, No. 10, 42–44.
- Ishtiaque S.M. and Swaroopa T.K. (1998), 'Internal Structure and Properties of DREF-3 Yarns', *Asian Text. J.*, 7, No. 10, 28–33.
- Ishtiaque S.M. and Agrawal D. (2000), 'Internal structure of sheath fibre in DREF-3 yarn', *J. Text. Inst.*, 91, Part 1, 546–562.
- Ishtiaque S.M., Salhotra K.R. and Gowda R.V.M. (2002), 'Influence of filament core surface structure on tensile properties of DREF-3 yarns', *Indian J. Fibre Text. Res.*, 27, 18–24.
- Ishtiaque S.M., Salhotra K.R. and Gowda R.V.M. (2003a), 'Friction spinning', *Textile Progress*, Oxford, UK.
- Ishtiaque S.M., Das A. and Yadav P. (2003b), 'Properties of woven fabrics containing core-sheath DREF-3 yarn in weft', *Indian J. Fibre Text. Res.*, 28, 260–264.
- Ishtiaque S.M., Das A. and Vishnoi P. (2005), 'Twist structural characteristics of friction spun yarns', *J. Text. Inst.*, 96, 454–458.
- Ishtiaque S.M., Das A. and Vishnoi P. (2006a), 'Influence of process parameters on migration characteristics of open-end and core-sheath friction spun yarns', *J. Text. Inst.*, 97, 211–222.
- Ishtiaque S.M., Das A., Vishnoi P. and Singh S.N. (2006b), 'Influence of process parameters on air speed in fibre transport duct of the DREF-3 machine: Part I', *J. Text. Inst.*, 97, 401–408.
- Ishtiaque S.M., Das A., Vishnoi P. and Singh S.N. (2006c), 'Influence of modified transport duct on air flow, yarn structure and properties: Part II', *J. Text. Inst.*, 97, 409–418.
- Ishtiaque S.M., Das A. and Prashant P. (2007), 'Friction spinning machine variable and yarn structure: Configuration of fibres in yarn in relation to machine variables', *J. Text. Inst.*, 98, 345–354.
- Karnon I. (1986), 'Friction Spinning – the Masterspinner', *Text. Month*, March, 34–37.
- Kato H. (2004), 'The development of ultra high speed spinning machine', Doctoral thesis, Gifu University, Gifu, Japan.
- Kato H., Konda F., Okamura M., Merati A.A. and Saeki H. (1999), 'Yarn tail structure in friction spinning', *Text. Res. J.*, 69, 214–219.
- Kimmel L.B. and Sawhney A.P.S. (1990), 'Comparison of DREF-3 cotton yarns produced by varying yarn core ratios and feed rates', *Text. Res. J.*, 60, 714–718.
- Konda F., Okamura M. and Merati A.A. (1996a), 'Effect of suction air pressure in friction spinning on yarn properties', *Text. Res. J.*, 66, 446–452.
- Konda F., Okamura M., Merati A.A. and Yokoi T. (1996b), 'Fibre speed and yarn tension in friction spinning', *Text. Res. J.*, 66, 343–348.
- Krause H.W. (1985), 'Staple-fibre spinning systems', *J. Text. Inst.*, 76, 185–195.
- Krause H.W. and Soliman H.A. (1991), 'Fibre assembly in friction spinning – Reply', *J. Text. Inst.*, 82, 113–114.
- Langer R. (1998), 'Friction-spinning with controlled orientation of fibre presentation', *Melliand Textilber.*, 79, 217–220 (E51-E52).
- Lord P.R. and Radhakrishnaiah P. (1987), 'Tenacities of plied friction-spun, rotor-spun, and ring-spun yarns', *J. Text. Inst.*, 78, 140–142.
- Lord P.R. and Rust J.P. (1990a), 'The surface of the tail in open-end friction spinning', *J. Text. Inst.*, 81, 100–103.
- Lord P.R. and Rust J.P. (1990b), 'Twist distribution in open-end friction-spun yarn', *J. Text. Inst.*, 81, 211–213.
- Lord P.R. and Rust J.P. (1991a), 'Fibre assembly in friction spinning', *J. Text. Inst.*, 82, 109–113.

- Lord P.R. and Rust J.P. (1991b), 'Fibre assembly in friction spinning', *J. Text. Inst.*, 82, 465–478.
- Lord P.R., Joo C.W. and Ashizaki T. (1987), 'The mechanics of friction-spinning', *J. Text. Inst.*, 78, 234–254.
- Louis G.L., Saluan H.L. and Kimmel L.B. (1985), 'Comparison of properties of cotton yarns produced by the DREF-3, ring, and open-end spinning methods', *Text. Res. J.*, 55, 344–351.
- Lünenschloss J. and Brockmanns K.J. (1982), 'Review of open-end friction spinning', *Melliand Textilber. (Eng. Edn)*, 11, 258–259.
- Lünenschloss J. and Brockmanns K.J. (1985), 'Mechanisms of OE-friction spinning', *Int. Text. Bull., Yarn Forming*, 31, No. 3, 29–59.
- Manich A.M., Castellar M.D. and Barella A. (1992), 'Twist and linear density coefficient of variation-length curves for polyester/cotton yarns spun by different processes', *Text. Res. J.*, 62, 115–120.
- Melliand Textilberichte*, (1988), 'Spinning 2000 – the spinning industry in the year 2000', *Melliand Textilber. (Eng. Edn)*, 17, 396–397.
- Merati A.A. (1999), 'A study on spinning specification and yarn properties in friction spinning', Doctoral thesis, Gifu University, Gifu, Japan.
- Merati A.A. and Okamura M. (2000a), 'Fiber feeding onto the yarn tail in friction spinning. Part II: Convergent fiber transport channel', *Text. Res. J.*, 70, No. 11, 974–980.
- Merati A.A. and Okamura M. (2000b), 'Hollow yarn in friction spinning, Part I: Tensile properties of hollow yarn', *Text. Res. J.*, 70, No. 12, 1070–1076.
- Merati A.A. and Okamura M. (2001), 'Hollow yarn in friction spinning, Part II: Yarn structure and its deformation under axial tension and lateral forces', *Text. Res. J.*, 71, No. 5, 454–458.
- Merati A.A. and Okamura M. (2003), 'Limits of hollow yarn in friction spinning', *Text. Res. J.*, 73, No. 6, 496–502.
- Merati A.A. and Okamura M. (2004), 'Production of medium count yarns from recycled fibers in friction spinning', *Text. Res. J.*, 74, No. 7, 640–645.
- Merati A.A. and Okamura M. (2005a), 'A unique method of producing two-component yarns in friction spinning', *Res. J. Text. Apparel*, 9, No. 2, 9–15.
- Merati A.A. and Okamura M. (2005b), 'Effect of draw-off angle on the yarn properties in friction spinning', *Text. Res. J.*, 75, No. 12, 812–818.
- Merati A.A., Konda F., Okamura M. and Marui E. (1997), 'Analysis of yarn tension in the yarn-forming zone in friction spinning', *Text. Res. J.*, 67, 643–653.
- Merati A.A., Konda F., Okamura M. and Marui E. (1998a), 'False twist in core yarn friction spinning', *Text. Res. J.*, 68, 441–448.
- Merati A.A., Konda F., Okamura M. and Marui E. (1998b), 'Filament pre-tension in core yarn friction spinning', *Text. Res. J.*, 68, 254–264.
- Merati A.A., Okamura M. and Marui E. (2000), 'Fiber feeding onto the yarn tail in friction spinning. Part I: Flow pattern in fiber transport channel and fiber landing on the yarn tail', *Text. Res. J.*, 70, No. 10, 894–901.
- Miao M., How Y.L. and Ho S.Y. (1996), 'Influence of spinning parameters on core yarn sheath slippage and other properties', *Text. Res. J.*, 66, 676–684.
- Nierhaus W. (1986), 'Theory and Practice of Modern Spinning Methods', *Text. Month*, December, 18–21.
- Oxenham W., Zhu R.Y. and Leaf G.A.V. (1992), 'Observations on the tensile properties of friction-spun yarns', *J. Text. Inst.*, 83, 621–623.
- Padmanabhan A.R. (1989), 'A comparative study of the properties of cotton yarns spun on the DREF-3 and ring- and rotor-spinning systems', *J. Text. Inst.*, 80, 555–562.

- Padmanabhan A.R. (1991), 'Properties of man-made fibre yarns spun on DREF-3 spinning system', *Indian J. Fibre Text. Res.*, 16, 241–245.
- Padmanabhan A.R. and Ramakrishnan N. (1993), 'Influence of process parameters on the properties of friction-spun yarns', *Indian J. Fibre Text. Res.*, 18, 14–19.
- Ray T.K., Sarkar D. and Katua D.P. (1997), 'Jute-blended yarns from DREF-3 technology', *Text. Asia*, 28, No. 2, 60–63.
- Rust J.P. and Lord P.R. (1991), 'Variations in yarn properties caused by a series of design changes in a friction spinning machine', *Text. Res. J.*, 61, 645–655.
- Ryu W.Y., Merati A.A. and Okamura M. (2000), 'Tensile properties of hollow yarn by friction spinning', *Journal of the Korean Fiber Society*, 37, No. 8, 463–469.
- Saad M.A. and Sherouf A.M. (1989), 'Yarn tension variations in friction spinning', *Text. Asia*, 20, No. 11, 61–64.
- Salhotra K.R. (1992), 'An overview of spinning technologies: possibilities, applications and limitations', *Indian J. Fibre Text. Res.*, 1992, 17, 255–262.
- Salhotra K.R., Chattopadhyay R., Kaushik R.C.D. and Dhamija S. (1999), 'Twist structure of friction spun yarns', *J. Text. Inst.*, 90, Part 1, 637–642.
- Salhotra K.R., Banerjee P.K. and Gowda R.V.M. (2000), 'A comparative study on quality of acryl and cotton terrysock fabrics produced from ring, rotor and DREF-3 yarns', *Indian J. Fibre Text. Res.*, 25, 246–250.
- Salhotra K.R., Chattopadhyay R., Dhamija S. and Kaushik R.C.D. (2002), 'Twist structure of friction-spun yarns: Part I – Open-end DREF-2 yarns', *Indian J. Fibre Text. Res.*, 27, 122–129.
- Salhotra K.R., Chattopadhyay R., Dhamija S. and Kaushik R.C.D. (2003), 'Twist structure of friction-spun yarns: Part II – Core-spun DREF-3 yarns', *Indian J. Fibre Text. Res.*, 28, 16–22.
- Sengupta A.K., Chattopadhyay R., Venkatachelaipathi G.S. and Padmanabhan A.R. (1992), 'Influence of spin finish and core-sheath ratio on the mechanical properties of friction spun yarns', *Melliand Textilber.*, 73, 224–226 (E83–E84).
- Shantong Z. (1990), 'A theoretical approach to the fundamental relationships in the friction-spinning process', *J. Text. Inst.*, 81, 79–85.
- Stalder H. and Soliman H.A. (1989), 'A study of the yarn formation process during friction spinning', *Melliand Textilber. (Eng. Edn)*, 18, 44–46.
- Thierron W. (1985), 'The flexural rigidity of polyester-fibre-cotton yarns produced on the ring-, rotor-, and friction-spinning systems', *J. Text. Inst.*, 76, 454–458.
- Thierron W. and Hunter L. (1984), 'Practical experience with the friction-spinning machine', *Melliand Textilber. (Eng. Edn)*, 13, 226–228.
- Tyagi G.K., Salhotra K.R. and Gupta S. (1995), 'Effect of core-wrapper ratio and spinning speed on physical characteristics of acrylic DREF-3 yarns', *J. Text. Inst.*, 20, 136–138.
- Tyagi G.K., Kaushik R.C.D. and Salhotra K.R. (2000), 'Radial packing density and related properties of polyester DREF-3 yarns', *Indian J. Fibre Text. Res.*, 25, 20–24.
- Ulku S., Ozipek B. and Acar M. (1995), 'Effects of opening roller speed on the fibre and yarn properties in open-end friction spinning', *Text. Res. J.*, 65, 34–39.
- Wei M. (1996), 'The twisting dynamic analysis of friction spinning', *J. Text. Inst.*, 87, 457–466.
- Zhu R.Y., Leaf G.A.V. and Oxenham W. (1993), 'Fibre behaviour in the twisting zone of a friction-spinning process', *J. Text. Inst.*, 84, 57–67.

---

R. A. ANGELOVA, Technical University of Sofia, Bulgaria

**Abstract:** Air-jet spinning is the most promising technology for production of staple fibre yarns. The chapter first reviews the history of the development and the basic air-jet spinning methods. It then describes the types of fibres used and the particularities of the fasciated structure. The chapter then discusses the modelling of the swirl flow and the flow–yarn interaction as a way to investigate air-jet spinning.

**Key words:** air-jet spinning, air-jet yarns, MJS yarns, MVS yarns.

## 12.1 Introduction

Air-jet spinning is the most promising spinning method at the beginning of the twenty-first century. It offers the fastest means of industrial production of staple fibre yarns. The main feature that distinguishes the morphology of air-jet spinning from the other up-to-date technologies, is the use of swirling airflow in the stage of inserting a twist into the yarns.

The idea for using air-jet currents as a twisting element for spinning of staple fibre yarns has existed for decades. In the history of air-jet spinning development, several methods can be found, but probably the first one is the Goetzfried method, which is a result of long-standing attempts to use air-jet flow as a twisting device (Wulfhorst 1986).

The Goetzfried method was based on the open-end spinning principle: fibres from a sliver were separated and transported to the open end of an already spun yarn (as in the case of the later developed rotor spinning method). The control of the spinning and twisting was performed by changing the parameters of the airflow, which was a very complicated task from the point of view of the physical process itself.

Only in the 1950s was swirling airflow successfully used as a twisting element in the process of texturizing (even today this is one of the most popular methods for production of texturized filaments). The replacement of the continuous filaments, which were fed to the nozzle entrance, with staple fibres led to an unexpected result – the fibres were spun into a yarn. This yarn had a unique and unknown structure: a core of relatively parallel fibres, wrapped by a small quantity of surface fibres (US Patent 1963). The structure was called ‘fasciated’ (Heuberger *et al.* 1971). The term ‘fasciated’ stems from ‘fasce’: a bundle of rods, wrapped with ribbons.

In 1963 air-jet spinning achieved its commercial realization through the Rotofil method and machine of E. I. Du Pont de Nemours and Co. (Heuberger *et al.* 1971) which had only one spinning nozzle. Although the market did not accept the yarns, the Du Pont method initiated several research studies and patents in the field.

In 1973 another air-jet spinning method was demonstrated in Poland: PF-1 (Angelova 2001, Witczak and Golańsk 2007). This spinning process was based on a nozzle configuration of three injectors, which generated a swirl flow in the nozzle chamber. Yarns of 18–63 tex were delivered with a speed of 80–200 m/min. Unfortunately the PF-1 method used the same open-end principle as the Goetzfried method, which gave an unstable spinning process and showed no commercial appeal. The same was the situation with the PAM-150 method (Angelova 2001) developed in the former Soviet Union. It did not reach wide industrial application, as the air-jet spun yarns were very weak and needed additional folding and twisting at a delivery speed of only 20–25 m/min.

A renaissance in the historical development of air-jet spinning started with the MJS machine of the Japanese company Murata Machinery Ltd (Murata Jet Spinner). This novel air-jet spinning machine was introduced for the first time at ATME-I 1982 and attracted the attention of specialists with its capability of spinning fine count yarns at a delivery speed of *ca.* 150 m/min. The International Exhibition of Textile Machinery ITMA'83 is considered to be the most important event in the history of the air-jet spinning method. Together with Murata's MJS, air-jet spinning machines were exhibited by Howa (Fasciated Spinning – FS) and Toyoda (Toyoda Jet Spinner – TJS). The main differences between the three types of machines were:

- The number of spinning units – 60 one-sided units in the case of Murata's MJS, 120 twin-sided units in the case of Toyoda's TJS, and eight one-sided units in the case of Howa's FS
- The number of nozzles used per spinning position
- The delivery speed: 120–180 m/min in the case of Murata's MJS, 100–200 m/min in the case of Toyoda's TJS, and up to 180 m/min in the case of Howa's FS.

Subsequent years were very dynamic in air-jet spinning development. In 1985 at ATME-I in Greenville, Murata exhibited the MJS 801 machine, which produced yarns with linear density ranging from 10 to 80 tex, from both cotton and cotton/polyester blends of staple lengths up to 38 mm (Rudy 1985). The Toray Group came into the forum with the AJS 101 (Air-Jet Spinner) machine, which produced air-jet spun yarns with strength about 10% less than the strength of similar ring spun yarns. This was much better than the reported strength values of MJS yarns, which could reach about 50–60% of the strength of ring spun yarns. Hence, the Toray Group presented the

new AJS yarns as suitable for both warp and weft threads, while Murata's MJS yarns could be used only as weft threads and for knitting.

The main constructive difference between the AJS and MJS machines was that AJS used only one spinning nozzle (MJS had two nozzles), which led to a reduction of the energy consumption. Both machines had automatic knotting devices and worked at similar draft ratios (200 times for AJS and 250 times for MJS).

In 1986 the air-jet spinning method had already been assessed as one of the very promising industrial methods for production of staple yarns, particularly medium to fine yarn counts. At the same time 600 MJS machines, producing cotton/polyester yarns for bed linen, were installed in the US (Thomas 1988). The US company Spring Industries equipped a whole spinning mill with Murata machines and reduced its staff from 450 to 260 persons due to the extremely small number of breaks and easy maintenance.

At ITMA'87 Murata introduced a new version of its air-jet spinning machines: the MJS 802 with the new 'cotton nozzle', which could spin 100% cotton combed slivers into yarns. As a matter of fact this nozzle and the respective machines did not reach wide industrial application because of the high requirements for the sliver quality. However, Murata dominated in the field in comparison with the machines of Toray (AJS 102, which still could not produce cotton spun yarns). Howa and Toyoda did not present any of their former air-jet spinning machines. In their place, the German company Spindelfabrik Suessen appeared among the major competitors in the field of air-jet spinning machines.

Suessen presented its PLYfiL method for production of two-folded air-jet spun yarns with low twist. At the beginning of the development the two-folded yarns had to be additionally twisted, but later on the machine was linked to a two-for-one twister unit – SpinAssemblyWinding (SAW). The PLYfiL method was applicable for both short-staple fibres (PLYfiL-1000 machines) and long-staple fibres (PLYfiL-2000 machines). PLYfiL-1000 accommodated cotton fibres up to 50 mm in length and PLYfiL-2000 accommodated worsted wool fibres up to 220 mm in length. Cotton yarns of 12.5  $\times$  2 tex were spun at a delivery speed of 200 m/min, while wool/polyester blends (45/55%) of 14  $\times$  2 tex were spun at a delivery speed of 300 m/min (Angelova 2001).

At ATME 1989, Murata, probably influenced by the idea of Suessen, developed and presented a spinner, MTS-81 (Murata Twin Spinner) for production of two-folded yarns. The principle of the MJS series was used for producing two parallel single yarns, which were taken up on the finished package. The package was directly fed to a two-for-one twister for subsequent twisting.

Murata launched two new air-jet spinning machines as well: the 802H and the 804 RJS respectively. The 802H system was equipped with a five-line drafting system, which allowed coarse slivers to be processed at high

speeds – up to 300 m/min. A modified nozzle, placed closer to the drafting unit to minimize ballooning, was used to assist high speeds (Goswami 1998). The construction of the 804 RJS was similar to that of the 802H except that the second nozzle was replaced with a set of rubber-covered balloon rollers. It was claimed that the new feature would reduce the energy consumption and yarn hairiness, resulting in a structure more similar to the ring spun structure. Although the production speed was very high (up to 400 m/min), the 804 RJS has not proven to be a commercial success.

The development of the air-jet spinning method continued at a steady pace till 1999, when Murata presented at ITMA'99 its new machine and method – the Murata Vortex Spinner (MVS). Even before their official demonstration MVS machines were installed in the USA. MVS machines were able to produce pure cotton yarns and yarns from cotton and chemical fibre blends at 400 m/min. According to company information, the new developed nozzle enables yarns to be produced with a structure very similar to the structure of ring spun yarns.

During the last international exhibition, ITMA 2007, Murata Machinery Ltd (or its textile machinery division Muratec) showed the MVS 61 machine, which was spinning carded cotton slivers into a Ne 40 yarn at a delivery speed of 400 m/min. A new challenge for the Japanese company was the exhibition of vortex units, which were spinning 100% wool staples (19.5 mm) into Nm 48 yarn at 250 m/min. It would be a matter for future observation if this possibility could be accepted by the worsted yarns market – one of the most conservative in the world of application of new spinning methods (Oxenham 2007).

## 12.2 Basic air-jet spinning methods

The current range of air-jet spinning methods can be divided into two basic groups:

- Methods for production of single spun yarns – MJS and MVS of Murata and AJS of Toray
- Methods for production of two-folded yarns – PLYfiL of Suessen and two-ply (MTS) of Murata.

The common characteristic of all methods is that swirling airflows, generated in one or more spinning nozzles, are used as a twisting element. The main steps of the process of yarn formation are shown in Fig. 12.1.

Classical three-line, four-line and five-line high-speed drafting systems are used for drawing of the staple-fibre slivers in the different constructions of air-jet spinning machines. However, these high-speed drafting systems could represent a real limitation of both production speed and quality of air-jet spun yarns. The high rotating speed of the drafting rollers (necessary for

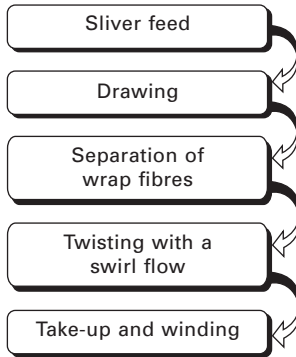

12.1 Steps of yarn formation in air-jet spinning.

the faster supply of fibres into the spinning nozzles) provokes the formation of turbulent eddies at the inlet of the rollers. The interaction between the eddies and the drafted strand leads to misalignment of some of the fibres, which results in higher yarn irregularity and neps. This problem was recently investigated by Bergada *et al.* (2007). They studied the air currents in the drafting system both experimentally, by using Laser-Doppler Anemometry (LDA), and numerically, by 3D simulations. The study has given a deep insight into the vortex structure into the eddies, their dimensions and decay along the cylinder axis.

The specific actions in air-jet spinning the separation are wrap fibres and the twisting of these fibres around the core of parallel fibres by means of swirl flow, generated in one or more nozzles.

### 12.2.1 Separation of the wrap fibres

One of the main differences between air-jet spinning methods can be found in the mechanism of the separation of the peripheral fibres in the drafted strand from the core fibres. The peripheral fibres play the role of wrap fibres in the fasciated structure as they are wound around the parallel fibres of the core to form the spun yarn.

The problems of the appearance and control of wrap fibres within the process of air-jet spun yarn formation are discussed in several studies (Kato 1986, Grosberg *et al.* 1987a, 1987b, Krause and Soliman 1989, Coll *et al.* 1992). The main conclusion from these studies is that twisting of the wrap fibres around the core fibres can be guaranteed only if one of the fibre ends is held within the core of fibres. The action of a twisting moment  $M_t$  on the free fibre end will then lead to twisting of the fibre around the core. This process is schematically presented in Fig. 12.2.

The long-term work of different machine-building companies on the

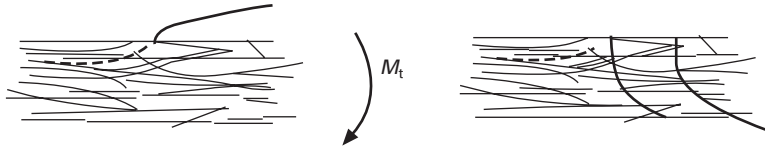

12.2 Twisting of a wrap fibre around the core or parallel fibres.

spinning of staple fibre yarns by means of air-jets led to the creation of different mechanisms for wrap yarn formation, through:

- injected air currents – the methods of Murata (MJS and MTS) and Suessen (PLYfiL)
- confluence of flows – the Toray method
- additional influence of mechanical devices on the false twist – the Goetzfried, Toyoda and Murata (MVS) methods
- untwisting in the opposite way to already twisted yarn – Murata’s MJS and MTS methods.

Although the technique of yarn formation is unique to each of these different methods, the structures of the resulting air-jet yarns are quite similar.

### 12.2.2 Twisting of the wrap fibres around the core fibres

By contrast with the separation of wrap fibres, the process of twisting them around the core of parallel fibres requires only one necessary condition: the swirl flow action. The means of formation of the swirl flow could be different, as well as the geometry of the nozzle and the number of nozzles used. However, all air-jet spinning methods – former and up-to-date – use the same swirl flow phenomenon.

### 12.2.3 MJS method of Murata

Figure 12.3 shows the basic principle of the MJS method. Two nozzles (N1) and (N2) are used as a twisting element. They are situated between the front rollers (FR) of the three-line drafting system and the delivery rollers (DR). The second nozzle (N2) is the real twisting nozzle, while the first one (N1) is used for wrap fibre formation. The drafted strand leaves the front rollers of the drafting system and subsequently enters the two spinning nozzles. The delivery rollers (DR) take up the yarn and transport it to a bobbin for winding.

Currently, two theories exist concerning the process of yarn formation in the case of MJS. The first theory was presented in detail in the studies of Kato (1986), Stalder (1988) and others. This theory claims that the swirl flow in the second nozzle (N2) leads to the appearance of false twist in the

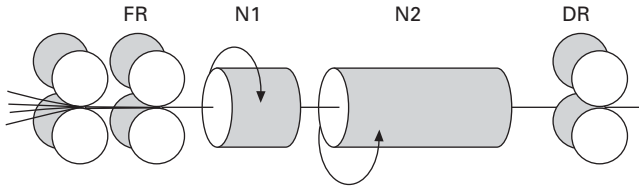

12.3 MJS principle (see text).

drafted strand between the front rollers (FR) and the delivery rollers (DR). At the same time the yarn ballooning in nozzle N1 provokes the formation of wrap fibres with one free end and the twisting of these fibres around the core, which is already twisted in the opposite direction by the swirl flow in the second nozzle (N2). During the consequent transition of the wrap fibres through the second nozzle (N2), additional wraps (twist) are added to the preliminary twist of the wrap fibres, due to the untwisting of the core fibres in the real twisting nozzle (N2). Thus higher numbers of wraps are obtained and a stronger yarn is spun.

This point of view was shared by Krause (1985) as well. However, in later papers (Krause and Soliman 1989) a new theory about MJS yarn formation was proposed. The essential point of the new theory is that just before the real spinning nozzle (N2), fibres with free ends that will form wraps have one of three twist profiles:

- Very small twist, to give a preliminary wrap direction which coincides with the direction of the twisted core fibres
- No twist
- Twist that gives a preliminary wrap opposite in direction to the twist of the core fibres.

The first possibility is the most frequently observed, while the last is very rare. It is claimed that the above fibres, being situated in the periphery of the drafted strand, receive less twist as they start to play the role of wrap fibres. This second theory goes on to propose that the actual wrapping of the free lengths of fibres around the core of parallel fibres occurs in the second nozzle (N2). The swirl flow in the second nozzle (N2) untwists the core of the yarn to give the straight parallel arrangement of the fibres. Simultaneously the fibres forming wraps, owing to their small preliminary wraps, are unwrapped and then wrapped in the opposite direction around the core.

A thesis similar to the second theory for MJS yarn formation was presented in the basic work of Grosberg *et al.* (1987a). It was stated there that the wrap fibres are twisted in the same direction as the core fibres before the second nozzle (N2), but with fewer twists. This statement was proved by experimental results as well.

### 12.2.4 PLYfil method of Suessen

Figure 12.4 presents the basic principle used in the PLYfil air-jet spinning machine of Spindelfabrik Suessen (Germany). Each of the spinning units consists of two pairs of nozzles. The first nozzle in the pair is a suction nozzle with radial injectors (RN). It plays the role of a suction element, which draws the drafted strand from the front roller's nip of the five-line drafting system into the spinning nozzle. The second nozzle is the real spinning nozzle (SN) with tangential injectors. The inclination angle of the tangential injectors in the spinning nozzle is  $90^\circ$  by contrast with the MJS method, where the injectors are tangentially inclined.

A theory of the process of yarn formation in the PLYfil air-jet spinning method was developed by Angelova (2001). The theory was based on both numerical and experimental study of the phenomena. It was found that the process of separation of the leading ends of the wrap fibres is provoked by the axial velocity component of the swirl flow. The wrap fibres are twisted around the core of parallel fibres due to the action of the tangential velocity component of the swirl flow. The two yarns are doubled and taken up together by the delivery rollers. Afterwards the ply yarn is transported to a two-for-one twister unit.

### 12.2.5 MVS method of Murata

Murata vortex spinning (MVS) is based on the already existing air-jet spinning technology by Murata, but essentially differs in principle from the MJS

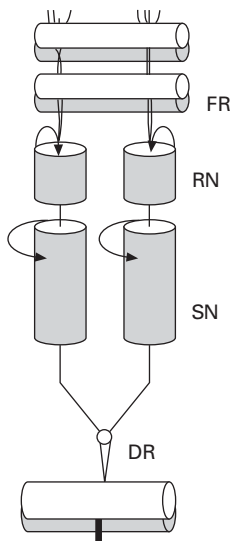

12.4 Principle of PLYfil (see text).

method because of the geometry of the air-jet twisting device used – Fig. 12.5 (US Patent 1996). This device includes a nozzle block with injectors for the generation of swirl flow, a needle holder, a hollow spindle and a guide member. After leaving the four-line drafting unit, the drafted strand is introduced through the needle holder into the nozzle block. The guide member, associated with the needle holder, protrudes towards the inlet of the spindle (US Patent 1996).

The swirl flow inside the nozzle block acts on the fibre bundle, causing the leading ends of the fibres to be wound gently around the holder and the guide member. Then the leading ends of the fibres are drawn into the hollow spindle by the fibres of the preceding portion of the fibre bundle, which are already twisted into a spun yarn. Later on, the trailing ends of the fibres are inverted at the inlet of the hollow spindle, separated from each other, and exposed to the swirl flow. The trailing ends of the fibres are thereby caused to twist around the portion of the fibre bundle being converted into a spun yarn to form a structure similar to an actually twisted spun yarn.

As with all other air-jet spun yarns, MVS yarns have a fasciated structure: a core of parallel fibres, held together by wrap fibres. However, this structure differs from that of MJS yarns in that a higher number of wrapper fibres can be found on MVS yarns due to the intensive formation of wrap fibres around the entire periphery of the fibre bundle.

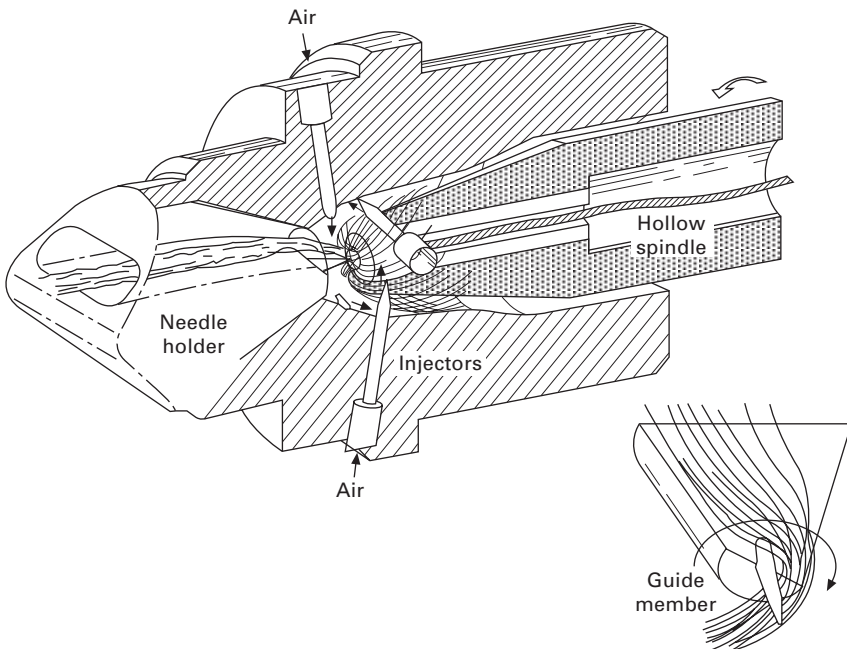

12.5 Principle of MVS (US Patent 1996).

### 12.3 Types of fibres used

Several fibre properties govern the successful application of the air-jet spinning process. In order of importance, these properties are:

- Fineness (fibre micronaire or denier)
- Cleanliness
- Strength
- Length and length irregularity
- Friction coefficients – ‘fibre-to-fibre’ and ‘fibre-to-nozzle’.

The fineness of the fibres is of great importance for yarn quality, as in the case of the rotor spinning method. The higher the number of fibres in the yarn cross-section, the fewer are yarn breaks during spinning and the fewer the faults in the yarn, as well as the better is the fabric handle and crease resistance (Lord 1987, Kaushik *et al.* 1993). On the other hand, the use of finer fibres increases the number of core fibres at the expense of the wrap fibres, which decreases the yarn strength (Basu and Oxenham 1992).

The importance of cleanliness of the material (slivers) can be found in two directions:

- *Blocking up of the axial inlets of the nozzles.* Due to their small diameter (around 2 mm) the spinning nozzles are very sensitive to even the tiniest particles.
- *Increasing yarn irregularity.* It was found (Walraf 2001) that both impurities and short fibres negatively influence the yarn irregularity due to the high draft ratio.

In general, fibres with higher strength should be used to spin air-jet yarns. However, the elongation of the fibres also has to be taken into consideration. As discussed by Basu (1999), increasing the tenacity of polyester fibres above a certain value (7 g/den) does not lead to significant improvement of the yarn strength because the very low elongation of these higher strength fibres will not facilitate tight wrapping of the yarn core.

The fibre length and length distribution have a significant influence on the formation of the fasciated structure. The longer the fibre, the higher is the number of twists of the wrap fibres around the core, and hence the stronger the yarn. Longer core fibres increase yarn tenacity as well, due to the higher contact surface between them. This is one of the reasons for problem-free use of polyester fibres for air-jet spinning at the very beginning of the development of air-jet spinning. This effect of fibre length can explain the reported observations by Bhortakke *et al.* (1999) of the doubled delivery speeds of cotton/polyester 50/50% blends during spinning on a MJS 802H machine, as compared to pure cotton blends.

The influence of the friction coefficients ‘fibre-to-nozzle’ and ‘air-to-nozzle’ was investigated by Oxenham and Basu (1993). They used three

different types of nozzles, made from different materials and applicable for MJS machines. The authors found that using a PTFE nozzle with the smallest friction coefficient would produce the strongest yarns. Rajamanickam *et al.* (1998b) studied the influence of 'fibre-to-fibre' friction and fibre strength on the yarn tenacity. The authors concluded that stronger yarns could be spun with increased 'fibre-to-fibre' friction coefficient.

Until the mid-1980s (ITMA'87) air-jet spinning lagged behind ring and friction spinning. By ITMA'87, with respect to the range of fibre types processed, spinning was largely of chemical fibres and blends of cotton with chemical fibres (mainly polyester). Only 6% of the world production of air-jet spun yarns was made from 100% cotton fibres. This situation changed with the 'cotton nozzle' MJS 802 machine, which claimed to manufacture combed slivers from 100% cotton fibres. The very high quality requirements for the sliver did not lead to large-scale production of cotton air-jet spun yarns.

It was reported by Basal and Oxenham (2003) that spinning pure cotton and a polyester/cotton blend with 83% cotton content was not possible for the MJS system. However, it was very difficult to spin yarn with an acceptable end-break level on this system when the blend ratio of polyester was less than 50%.

Since 1987 the PLYfiL method gave a new opportunity to produce twisted yarns from both short and long staples. Despite this, the problem with high quality cotton single yarns still remained.

A new stage in air-jet spinning started with the MVS method of Murata. The MVS machine could spin cotton and cotton blends in yarns with a ring-yarn-like structure at a speed of 400 m/min. This machine was probably the biggest surprise in the field of spinning at the end of the twentieth century.

Murata was the company that demonstrated the application of air-jet spinning machines for production of fancy yarns. In 1987 it exhibited a MJS machine, half of the units of which produced 100% polyester yarns and the other half fancy yarns. A coloured thread, which was broken in the drafting system, made the effects when twisted together with the row fibres coming from the drafted sliver (Lawrence 1988). The MJS 802HR machine is suitable for production of core-spun yarns and 100% synthetic fibres at a draft ratio of 300 times (Hergeth 2001). Recently a study was reported on the possibilities of using the MVS machine for the production of elastic core-spun yarns (Ortlek and Ulku 2007).

Several reported studies deal with the problem of the spinning of different types of fibres using Murata's MJS method: 100% polyester (Grosberg *et al.* 1987a, 1987b), and viscose/polyester, cotton/viscose and cotton/polyester blends (Artzt and Dallmann 1989, Artzt and Gonzelmann 1989, Chasmawala *et al.* 1990, Bhortakke *et al.* 1999). Baig *et al.* (2007) reported the possibility

of using the MJS system to produce jute yarns, comparing their quality with ring and rotor jute yarns. The effect of fibre type on the properties of PLYfiL yarns is discussed by Grill (1991), Fischer (1991) and Georgiev (1995a, 1995b). Basal and Oxenham (2003) and Ortlek and Ulku (2007) investigated the properties of MVS yarns in relationship to the fibres used.

## 12.4 Fasciated structure of air-jet spun yarns

The Air-jet spun yarns have a particular fasciated structure – a small quantity of wrap fibres (predominantly surface fibres) twisted around a core of parallel fibres. The compactness and the tenacity of the yarn are due to the wrap fibres, which exercise radial pressure over the parallel fibres and impede their slippage during the strain force’s action.

As has already been mentioned, the longer the fibres are, the better the yarn’s tenacity. The wrapping frequency is the other characteristic of the yarn geometry which influences yarn tenacity. For a constant fibre length characteristic, the higher the frequency of wrap the higher will be the yarn tenacity. Hence, the main aim in the spinning of short fibres is to increase the wrap frequency – see Fig. 12.6.

### 12.4.1 Types of fibres in the fasciated structure

A range of fibre types were used to investigate the morphology of air-jet spun yarn structures and to classify these structures (Kato 1986, Grosberg *et al.* 1987a, Lawrence and Baqui 1991). One of the most detailed classifications is presented in the work of Chasmawala *et al.* (1990) on the basis of 14.76 tex 100% PES yarns. This classification was used later as the basis for mathematical modelling and computer simulation for the prediction of yarn tenacity (Rajamanickam *et al.* 1997a, 1997b, 1998a, 1998b).

#### *Classification of air-jet fasciated yarn structures*

Three main types of fibres can be distinguished in the fasciated structure of air-jet spun yarns (Chasmawala *et al.* 1990) – Fig. 12.7:

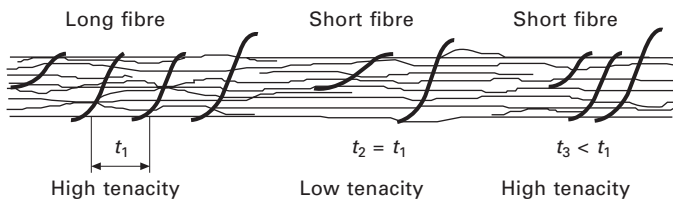

12.6 Influence of the length of the fibres and the wrapping step on the tenacity of air-jet spun yarns.

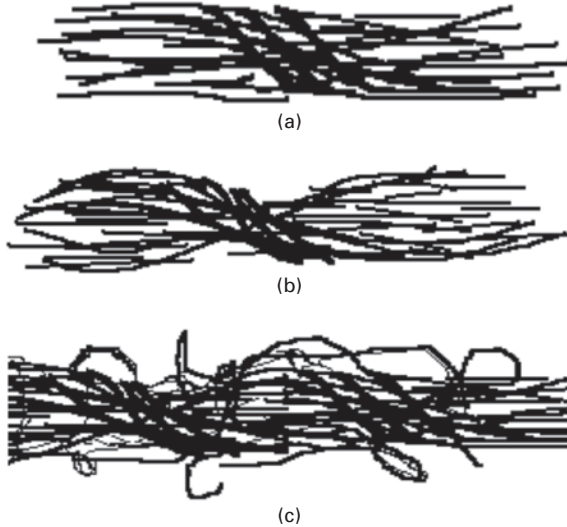

12.7 Types of fibres in the fasciated structure.

- *Core fibres*: These constitute the main body (core) of the yarn – Fig. 12.7(a). They are relatively parallel fibres, which are twistless or with a very small amount of twist; Grosberg *et al.* (1987a) and Krause and Soliman (1989) report that a small amount of twist exists in the core of MJS yarns. Microscope observations of PLYfiL yarns showed no twist in the core, and this is due to the different spinning principle of the PLYfiL method, compared to the Murata method (Angelova 2001).
- *Wrap fibres*: These are wound around the core fibres. Their helix angle and wrapping frequency are relatively constant – Fig. 12.7(a). Depending on their position and length, they can tighten the core fibres to give the yarn a wavy or crimped appearance – Fig. 12.7(b).
- *Wild fibres*: These are very similar to wrap fibres. However, their helix angle and wrapping frequency vary along the yarn length and give an irregular appearance to the spun yarn – Fig. 12.7(c).

Chasmawala *et al.* (1990) suggested two other types of fibres in addition to the main types: core–wild and wrap–wild fibres. A special methodology was developed for their classification, which depended on the visible length (under a microscope) of the particular fibre.

A quantitative assessment of the distribution of the different types of fibre configuration along MJS spun yarn was performed based on the experimental data of Chasmawala *et al.* (1990). The results showed that 59% of the fibres are core fibres, 17.6% are wrap fibres, 6.7% are wild fibres, 8% are core–wild and 8.7% are wrap–wild. A study of the structure of single PLYfiL yarn has shown that the same types of fibre configuration are applicable to these

yarns. However, core fibres are much more dominant than in the case of MJS yarns (Angelova 2001).

The different features of the MVS system led to an alternative wrap yarn structure in which the wrap fibres, which are much greater in number than is the case for MJS and PLYfiL yarns, form a sheath around the core fibres. Basal and Oxenham (2003) reported microscopic observations of the structure of MVS yarns, and concluded that MVS yarns have a two-part structure (core and sheath), which can be untwisted by hand.

Core and wrap fibres are mainly responsible for fibre tenacity under strain load. Hence the more wild, core-wild and wrap-wild fibres, the weaker the yarn. This conclusion from experimental data (Chasmawala *et al.* 1990) and mathematical models (Rajamanickam *et al.* 1997b) can explain the low tenacity values of PLYfiL single yarns: they have a much lower proportion of wrap fibres and more wrap-wild fibres in their structure, when compared to MJS yarns. The opposite is the case for MVS yarns compared to MJS yarns: there is a high proportion of wrap fibres in a sheath, uniformly distributed around the core fibres, and this gives the MVS yarns their higher tenacities (Basal and Oxenham 2003).

#### 12.4.2 Classes in the fasciated structure

One of the most important characteristics of the structure of air-jet spun yarns is that it varies along the yarn. Therefore the properties of the yarn could be different in different sections.

Most authors (Lawrence and Baqui 1991, Rajamanickam *et al.* 1997a) conclude that three classes can be observed along the fasciated air-jet spun yarn structure (however, other opinions also exist: Grosberg *et al.* 1987a). The classification is made on the basis of experimental study of the structure of MJS yarns. In the study of Angelova (2001) the same microscopic analysis is performed on the structure of single PLYfiL yarns. The conclusion was reached that *the structures of air-jet spun yarns are similar*, regardless of the method of production.

Figures 12.8, 12.9 and 12.10 show the three classes of fasciated structure of PLYfiL single yarns (Angelova 2001). They are similar to the classes in the structure of MJS yarns, as defined in the study of Lawrence and Baqui (1991). Figure 12.8 shows Class I of the fasciated structure: the core of parallel twistless fibres (or with very small twist) wrapped uniformly by a thin ribbon of fibres. The direction of the twist and the helix angle are relatively constant. The helix angle could be about 45°, and the core can be slightly crimped. Figure 12.9 illustrates Class II of the fasciated structure: the core of parallel twistless fibres (or with very small twist) wrapped by single fibres or a group of fibres. The direction of the twist changes from S to Z (with a prevalence of the Z-direction); the helix angle also varies. Figure 12.10

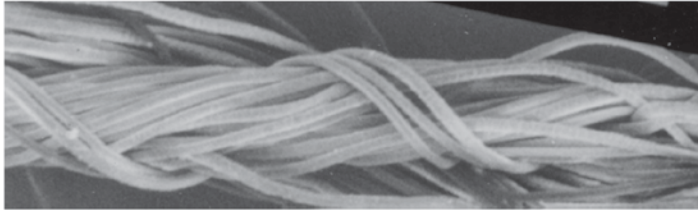
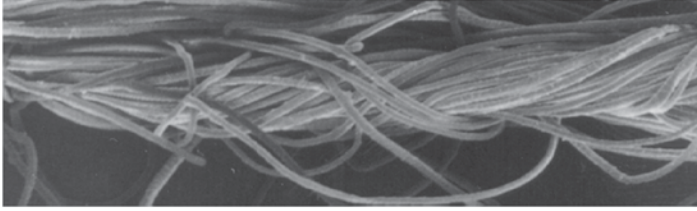

12.8 PLYfiL single yarn – Class I structure.

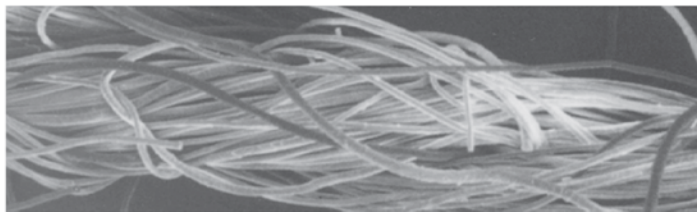
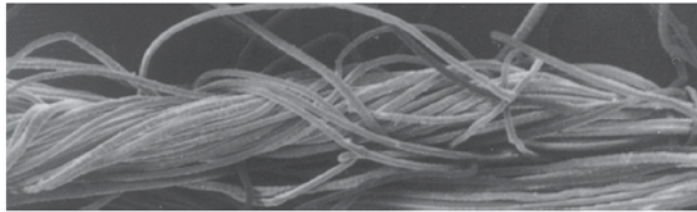

12.9 PLYfiL single yarn – Class II structure.

illustrates Class III of the fasciated structure: a core of unwrapped parallel fibres without twist or with very small twist. This structure appears similar to the structure of ring spun yarns.

MVS yarn structure is quite different from those of MJS yarns and PLYfiL single yarns (Basal and Oxenham 2003). It creates a theoretical challenge: *how to classify this new structure?* Although the wrap fibres are wound uniformly around the core, they do not form a ribbon as in the case of the Class I structure described above. Obviously Class II cannot be taken into consideration. Class III is also not appropriate, as a lot of wrap fibres exist in the MVS structure.

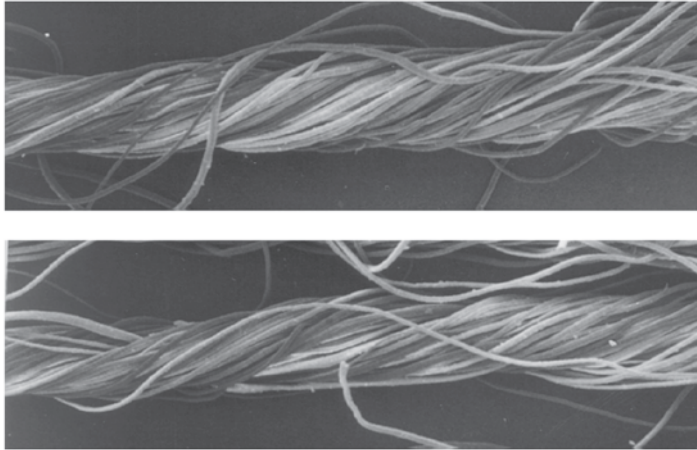

12.10 PLYfiL single yarn – Class III structure.

In order to include MVS yarns in the classification of the structure of air-jet spun yarns two approaches can be considered:

- To transform the description of the Class I structure from a ‘core of parallel fibres wrapped uniformly by a thin ribbon of fibres’ to a ‘core of parallel fibres wrapped uniformly by a ribbon *or a sheath* of fibres’; or
- To introduce a Class IV structure, which is unique to MVS yarns.

It is the author’s opinion that the first approach is more suitable, since sheath fibres of MVS yarns have the Class I configuration.

#### 12.4.3 Influence of different classes in the fasciated structure on the strength of the yarns

The influence of the different structures along the yarn on the yarn’s properties was experimentally investigated by Kato (1986), Grosberg *et al.* (1987a), Lawrence and Baqui (1991), Rajamanickam *et al.* (1997a), etc. Recent studies on MVS yarns (Basal and Oxenham 2003, Soe *et al.* 2004) also deal with the relationship between the core–sheath structure and the properties of the MVS yarns.

The high values of the tenacity are related to the greater number of Class I structures along the yarn. Though being also similar to Class I, a predominance of Class II does not correspond to a high tenacity. The reason for this is the poor binding effect of wild, core–wild and wrap–wild fibres in the Class II structure compared with the Class I structure. This means that only the formation of a Class I structure guarantees production of yarn with good tenacity.

The formation of different classes in the structure of air-jet spun yarns explains the difference in properties of MJS, PLYfiL and MVS yarns. Class I structure dominates in the structure of MJS and MVS yarns, while the dominating structure in PLYfiL single yarns is Class III which causes their low strength, consequent doubling and twisting becoming necessary to improve their tenacity. This particularity of PLYfiL single yarns is due to the principal features of the spinning process: high delivery speed and low twisting values in the spinning nozzle. On the other hand, the much higher preponderance of Class I structure in MVS yarns (the sheath formed by wrap fibres) explains the higher tenacity of MVS yarns compared to MJS yarns.

## **12.5 The basic principles of the twisting mechanism by swirl flow**

Studies of the swirl flow inside air-jet spinning nozzles have led to a detailed understanding of the ‘flow–yarn interaction’ and the process of yarn formation. Investigations of the flow have been carried out by means of experimental observations, physical modelling and numerical simulations.

### 12.5.1 Experimental investigation

This has been the best approach to obtain results for the flow parameters, like velocity and pressure, and for studying the interaction between the flow and the yarn. Traditional methods of measurement (hot-wire anemometer, or Prandtl tube) are not appropriate for determining the flow parameters inside the spinning nozzle because of the very small diameters of the nozzles – around 2–3 mm. The alternative for precise measurements is Laser-Doppler anemometry (LDA), but this requires constructing a transparent model of the nozzle of the actual dimensions, which is no easy task. However, Yu and Zhang (1996) report the use of LDA for air velocity measurements as well as for studying the influence of the nozzle design parameters on the flow characteristics. They observed the complex turbulent structure of the swirl flow inside the nozzle and their results were used by Zeng and Yu (2003) for verification of their numerical predictions.

### 12.5.2 Physical modelling

Physical modelling is an alternative to experimental modelling in which a scaled-up model is used to investigate the flow parameters. However, the complexity of the problem does not change significantly, compared to the experimental measurements.

The main difficulties are related to experimental measurement of the swirl flow in a physical model of the air-jet spinning nozzle, with the requirement

for similarity, i.e. similarity of the geometrical, kinematic and dynamic parameters of the flow (Stankov 1998b). The main obstacle arises from the fact that the flow changes from a compressible type (near the outlet cross-section of the injectors) to an incompressible type downstream. Therefore the flow is defined by two similarity numbers: Max (Ma) number and Reynolds (Re) number. The physical modelling itself is difficult, even impossible, to perform in its complexity, due to the contradictory relationship of these two numbers.

However, physical modelling of the flow in a scaled-up model of a spinning nozzle could be very useful for visualization of the flow–yarn interaction and determination of basic integral characteristics of the flow, i.e. flow rate and momentum. Similar to the LDA measurements, this requires making a transparent model. Such an experimental set-up was used by Angelova (2001) for studying the swirl flow in the spinning nozzle of the PLYfiL machine. The geometrical model of the nozzle, scaled up 25 times, was made of a transparent material. The model was used for visualization of the flow–yarn interaction and measurements of the ballooning frequency.

Experimental results for the relationship between the frequency of yarn ballooning and yarn linear density, vs. flow rate  $Q_{in}$  and air pressure  $P$  are presented in Figs 12.11 and 12.12 respectively. As would be expected, the higher the value of the injected flow rate and air pressure, the faster is the yarn motion. The ballooning frequency was found to be inversely proportional to the yarn linear density.

On the basis of the physical modelling other useful results can be obtained.

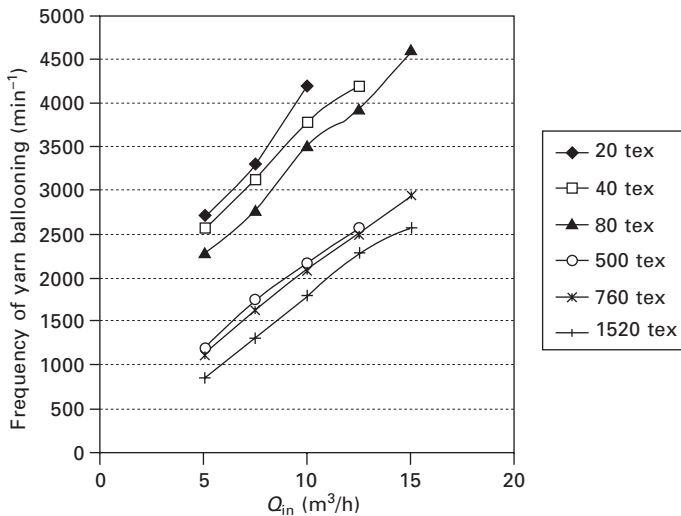

12.11 Relationship between frequency of yarn ballooning and flow rate through the injectors.

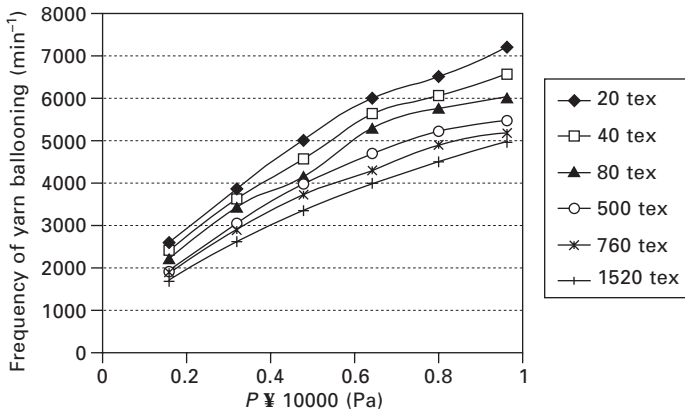

12.12 Relationship between frequency of yarn ballooning and air pressure.

Table 12.1 Relationship between coefficients *a* and *b* and the air pressure,  $v_{b,m} = a + b \ln T_t$

Pressure <i>P</i> , bar	<i>a</i>	<i>b</i>	<i>r</i> <sup>2</sup>
0.16	3133.24	-196.52	0.991
0.32	4608.86	-259.05	0.986
0.48	5839.42	-328.30	0.922
0.64	7332.83	-453.79	0.988
0.80	7671.98	-419.06	0.982
0.96	8381.66	-478.54	0.955

From Figs 12.11 and 12.12 the following equation was obtained for the ballooning frequency:

$$v_{b,m} = a + b \ln T_t \tag{12.1}$$

where  $v_{b,m}$  is the measured frequency of yarn ballooning ( $\text{min}^{-1}$ ) and  $T_t$  is the linear density of the yarn (tex). The coefficients *a* and *b* depend on the air pressure at the spinning nozzles, and can be determined according to:

$$a = f(P) = -556.877 + 9303.43\sqrt{P} \quad (r^2 = 0.988)$$

$$b = f(P) = 10.758 - 507.719\sqrt{P} \quad (r^2 = 0.929) \tag{12.2}$$

where *P* is the air pressure (bar) and *r* is the correlation coefficient. Table 12.1 systematizes the *a* and *b* coefficients for the different values of the air pressure used in the physical modelling.

A comparison between calculated and measured values of the balloon frequency of a 20 tex yarn during spinning is shown in Fig. 12.13. The extrapolated results show very good agreement between the theoretical and experimental values, which confirms the applicability of the equations developed.

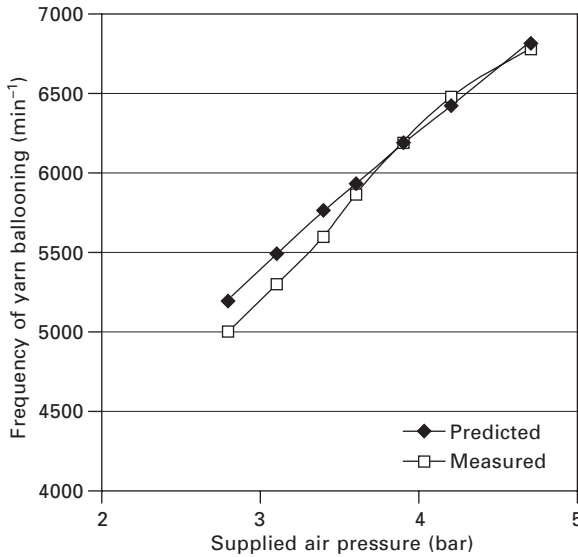

12.13 Comparison between predicted and measured values for yarn ballooning.

### 12.5.3 Numerical simulation

The swirl flow in the air-jet spinning nozzle is the main twisting element. The main characteristic of a swirl flow is the anisotropy of its turbulence structure. Even for axisymmetric flows (which is the case of the flow in the spinning nozzle) there are no zero values for the Reynolds stresses.

The mathematical model used for simulation of the flow is based on Navier–Stokes equations. However, the numerical simulation is practically based on the Reynolds-averaged Navier-Stokes equations. Direct numerical simulation (DNS method) is principally not excluded as a possibility, but it requires very high CPU time, which is an obstacle for its application (Stankov 1998a).

The complete system of Reynolds partial differential equations for a steady state ( $\partial/\partial t = 0$ ) and axisymmetric ( $\partial/\partial \varphi = 0$ ) flow in a cylindrical coordinate system includes:

- Transport equations:

$$\begin{aligned}
 \hat{r} \frac{\partial}{\partial x} V_x + V_r \frac{\partial}{\partial r} V_x = - \frac{\partial p}{\partial x} + \frac{\hat{r}}{\rho} \frac{\partial^2 V_x}{\partial r^2} + \frac{1}{r} \frac{\partial V_x}{\partial r} + \frac{\partial^2 V_x}{\partial x^2} \\
 - \frac{\partial}{\partial x} (\overline{rV_x^2}) - \frac{1}{r} \frac{\partial}{\partial r} (\overline{rV_r V_x})
 \end{aligned}
 \tag{12.3}$$

$$\begin{aligned}
 & \hat{\mathbf{E}} \mathbf{r} \frac{\partial}{\partial x} V_x + V_r \frac{\partial}{\partial r} V_r - \frac{V_j^2}{r} \\
 &= -\frac{\partial p}{\partial r} + \frac{\hat{\mathbf{E}} \partial^2 V_r}{\mathbf{E} \partial r^2} + \frac{1}{r} \frac{\partial V_r}{\partial r} + \frac{\partial^2 V_r}{\partial x^2} - \frac{V_r}{r^2} \\
 & \quad - \frac{\partial}{\partial x} (-\mathbf{r} \overline{V_r V_x}) - \frac{1}{r} \frac{\partial}{\partial r} (\mathbf{r} r \overline{V_r^2}) - \frac{1}{r} (\mathbf{r} V_j \overline{c^2})
 \end{aligned} \tag{12.4}$$

$$\begin{aligned}
 & \hat{\mathbf{E}} \mathbf{r} \frac{\partial}{\partial x} V_j + V_r \frac{\partial}{\partial r} V_j + \frac{V_r V_j}{r} = \frac{\hat{\mathbf{E}} \partial^2 V_j}{\mathbf{E} \partial r^2} + \frac{1}{r} \frac{\partial V_j}{\partial r} + \frac{\partial^2 V_j}{\partial x^2} - \frac{V_j}{r^2} \\
 & \quad - \frac{\partial}{\partial x} (\mathbf{r} \overline{V_x V_j}) - \frac{1}{r^2} \frac{\partial}{\partial r} (\mathbf{r} r^2 \overline{V_r V_j})
 \end{aligned} \tag{12.5}$$

where  $V_x$ ,  $V_r$  and  $V_\varphi$  are the mean velocity components in the  $x$ ,  $r$  and  $\varphi$  directions;  $V_x$ ,  $V_r$  and  $V_\varphi$  are the fluctuation components of the velocity in the  $x$ ,  $r$  and  $\varphi$  directions;  $p$  is the static pressure (Pa),  $\mathbf{m}$  is the dynamic turbulent viscosity (Pa.s) and  $\rho$  is the flow density ( $\text{kg/m}^3$ ).

- Continuity equation:

$$\frac{\partial}{\partial x} (\mathbf{r} V_x) + \frac{1}{r} \frac{\partial}{\partial r} (\mathbf{r} r V_r) = 0 \tag{12.6}$$

In order to be solved, the system defined by equations (12.3)–(12.6) needs the application of a turbulence model. The  $k - \varepsilon$  turbulence model is widely used for numerical predictions and is incorporated in all general-purpose software packages. Though appropriate for predictions of flows with high Reynolds (Re) numbers, the application of the  $k - \varepsilon$  turbulence model requires isotropy of the turbulence structure, which is not true in the case of swirl flows. However, the reported simulations of the PLYfiL spinning nozzle (Angelova 2001) and the MJS spinning nozzle (Zeng and Yu 2003) used the  $k - \varepsilon$  model.

Near the walls of the nozzle the Re number tends to zero, which requires the application of a low Reynolds model or wall-function in this zone. Both studies (Angelova 2001, Zeng and Yu 2003) used wall-functions for numerical reasons (better convergence and fewer grid points). The use of Reynolds stress turbulent models, which better correspond to the nature of the flow, does not, however, lead to much better predictions concerning the tangential velocity component, which is actually the most important for the twisting action of the swirl flow (Stankov 1998a).

Figure 12.14 shows a typical example of the predictions for the axial velocity component of the swirl flow in the PLYfiL nozzle ( $R = 1 \text{ mm}$ ),

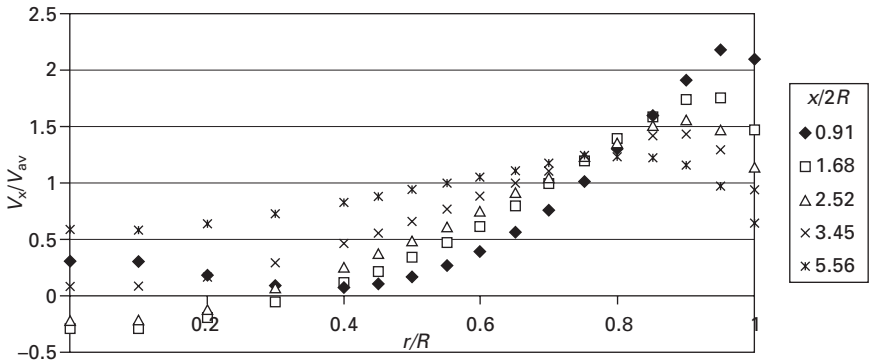

12.14 Axial velocity profiles (velocity of the jets through the injectors 200 m/s).

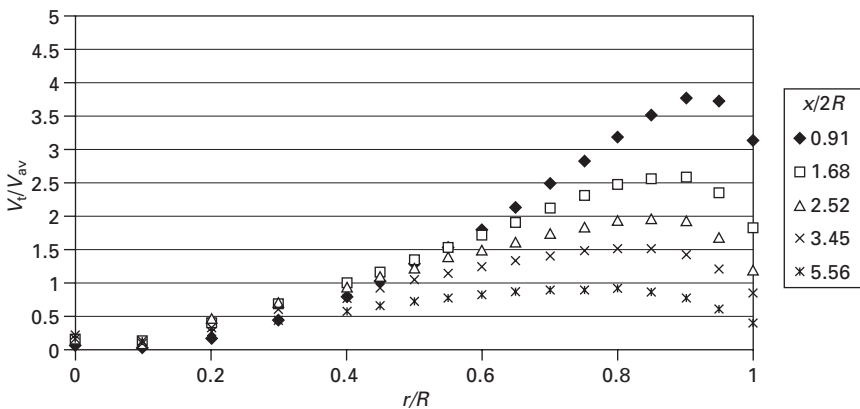

12.15 Tangential velocity profiles (velocity of the jets through the injectors 200 m/s).

obtained by Angelova (2001). The results clearly show the formation of the typical recirculation zone (with negative values of the axial velocity) and the development of the flow downstream. Figure 12.15 presents numerical results for the tangential velocity component, obtained for the same velocity of the jets through the injectors (200 m/s): obviously the main zone of the twisting is near the nozzle wall and in the regions close to the jet inlets (the beginning of the swirl flow formation). On the basis of the numerical results obtained, Angelova (2001) described the process of yarn formation in the PLYfiL air-jet spinning method.

Results for the axial and tangential velocity components for different values of the air pressure supplied by the injectors of the MJS spinning nozzle can be found in the study of Zeng and Yu (2003). The graphs show the influence of the air pressure on the development of the flow near the

nozzle axis and the walls – both axial and tangential velocity increase, while the distribution remains the same.

The numerical simulation of the flow in an air-jet spinning nozzle is not only appropriate for investigating the principle of twist insertion, but also important for the design of new spinning nozzles. The construction of a virtual model of the nozzle and the simulation of the flow inside it have several economic advantages for the manufacturers of air-jet spinning machines compared to experimental testing of nozzles with new geometries. However, in order for this approach to be used as a powerful design tool, the additional step of predicting the swirl flow–yarn interaction is required.

## 12.6 Simulation of the flow–yarn interaction

The simulation of the swirl flow–yarn interaction inside the nozzle is quite complex, because of the complex nature of turbulent flow. The motion of the yarn in the flow has to be modelled as a dynamic interaction. The complexity therefore also results from the fact that the ribbon itself and the component fibres have different properties from the fluid characteristics, e.g. elasticity, flexibility and large aspect ratio. However, it is not a case of two-phase flow as in the situation for coal combustion modelling, for example, where the fuel particles are spread into the air. With air-jet spinning there is no mixture between the two phases – fibres and air. Because of the very small diameter of the spinning nozzles the yarn will strongly affect the flow. However, the flow–yarn interaction is rather a case of a ‘flow-around-body’ problem (elastic body) than a two-phase flow problem.

The first attempt to model a fibre motion in a high-speed swirling flow was reported by Zeng and Yu (2004). They developed a two-phase flow model to simulate single fibre behaviour in the spinning chamber of the MJS nozzle. One of the best results from this investigation is the bead-elastic rod model of a fibre, developed by using an earlier conception of Cheng (1985). The new model, however, can be applied to high-speed air flows. The simulation was aimed at determining the influence of three parameters: first, nozzle air pressure; second, inclination angle of the injectors; and third, the fibre flexural rigidity on the formation of wrapping fibres and, consequently, on the yarn structure and tensile properties. The simulation was verified by visualization of the flow–yarn interaction.

The simulation of the swirl flow in a spinning nozzle can provide the necessary background for prediction of the flow–yarn interaction. The decisive role in this interaction is played by the tangential and axial velocity components of the swirl flow, while the influence of the radial velocity component can be neglected. The axial velocity plays an important role for the wrap fibre separation, while the tangential velocity twists the separated fibres around the core of the yarn (Angelova 2001, Zeng and Yu 2003).

The swirling of the flow provokes specific yarn motion inside the nozzle chamber, which can be defined as ‘ballooning’. The frequency of the ballooning  $\nu_b$  can be determined as (Angelova 2001)

$$\mathbf{n}_b = \frac{V_j}{2\mathbf{r}_b} \quad 12.7$$

where  $V_\varphi$  is the tangential velocity component and  $r_b$  the radius of the balloon.

The strength of yarns depends strongly on inserted twist. The experimental measurement of the twist of an air-jet spun yarn is very complex. By analogy, methods for determination of OE rotor spun yarns can be used. However, no methodology for yarn twist measurement has been reported in the literature. The only exception is the approach of Coll *et al.* (1992). It starts from the treatment that there is a strong correspondence between the frequency of the yarn ballooning inside the nozzle chamber and the yarn twist. Coll *et al.* (1992) called this twist ‘kinetic’ and experimentally verified equation (12.8):

$$C_k = \frac{\mathbf{n}_b}{V_{\text{del}}} \quad 12.8$$

where  $C_k$  is the kinetic twist, ( $\text{m}^{-1}$ ) and  $V_{\text{del}}$  is the delivery speed of the yarn.

Deriving the relationship between the tangential velocity component of the swirl flow, the frequency of the ballooning and the kinetic twist, Angelova (2002) presented results for the air-jet spun yarn twist based on numerical simulation of the swirl flow. The results were verified by experimental data from measurements of the kinetic twist during the real spinning process.

Figure 12.16 shows results for the kinetic twist of a 20 tex spun yarn, delivered at a speed of 250 m/min. The maximal value of the twist is obtained where the maximum of the tangential velocity component is situated: in the near wall regions and in the zone very close to the injector outlets. A zone of relatively constant values of the torsion can be found downstream, with the flow development ( $0.2 \text{ mm} < r < 0.8 \text{ mm}$ ). This situation is very favourable for the spinning process: the relatively large hoop, where the wrap fibres are wound around the core with almost constant twist, predetermines more random structure.

The results for the twist prediction can be used only for qualitative assessment of its influence on the strength of air-jet spun yarns. However, Zeng and Yu (2004) employed artificial neural network (ANN) models to predict yarn tensile characteristics of MJS yarns on the basis of the swirl flow simulation.

The ANN model used several input parameters for predicting the tenacity:

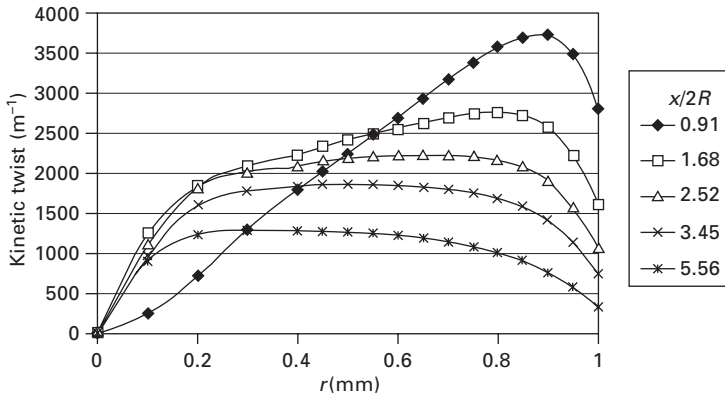

12.16 Kinetic twist predictions (yarn delivery speed 250 m/min).

pressure of the air supplied to both first and second nozzles, delivery speed, distance between front roller nip and first nozzle inlet, and the angle of inclination of the injectors of the first nozzle. The verification of the predicted values of the yarn tenacity showed good agreement between experimental and numerical results, confirming that ANN is a trustworthy method for prediction of this particular problem.

## 12.7 Properties of air-jet spun yarns

There are three groups of factors that influence the properties of air-jet spun yarns:

- *Material properties*: types of fibre, fineness, cleanliness, strength, length and length distribution, friction coefficient (already discussed in Section 12.3)
- *Process parameters*: air pressure (including air pressure in different nozzles if more than one), draft ratio, delivery speed, distance between the two nozzles, distance between the front nip rollers and the first nozzle, and condenser width
- *Geometry of the nozzles*: number of nozzles used, dimensions of the nozzles, number of injectors, material of the nozzles.

There is therefore a wide range of possible combinations of the above factors for influencing the yarn mechanical properties, as discussed in detail by Basu (1999), Angelova (2001) and Basal (2003). However, the strength of air-jet spun yarns is always lower than the strength of ring spun yarns. The strength of pure cotton MJS yarns is about 40–45% lower than the strength of similar cotton ring yarns, while in the case of cotton/polyester blends the strength is only 15–20% lower (Lünenschloss *et al.* 1986, Stalder 1990). Polyester–viscose blended yarns have about 15% lower tenacity. For

PLYfiL yarns (wool/polyester 45/55%) the tenacity of the twisted ply yarn is 10–20% lower than the tenacity of the twisted ring yarn (Georgiev 1995b, Angelova 1999).

The processes of doubling and twisting influence positively the strength of MJS yarns: twisted two-ply MJS yarns are 14–46% stronger than analogous ring yarns, and the twist liveliness improves significantly (Punj *et al.* 1997). This specific disadvantage of air-jet spun yarns can also be overcome via appropriate finishing of the fabrics.

The breaking elongation of air-jet spun yarns is quite similar to that of ring spun yarns. However, the finer the air-jet spun yarn, the lower its elongation at break.

Air-jet spun yarns have better evenness and fewer imperfections than ring spun yarns and rotor spun yarns. They are also less hairy and bulky than ring spun yarns (Barella *et al.* 1993). These properties are very useful for the weaving process. Figure 12.17 shows a comparison between ring and MJS yarns on the basis of the number of stops during weaving (made by using data reported by Basu 1999).

MVS yarns are stronger than MJS yarns due to the higher number of wrap yarns, but have lower elongation. Basal and Oxenham (2003) have found that MVS yarns are less hairy and more regular, with fewer imperfections (except nep formation).

### 12.8 Advantages and limitations of air-jet spinning

The main advantages of air-jet spinning can be found in two main directions: efficiency and flexibility. The efficiency of the method is attributed to the

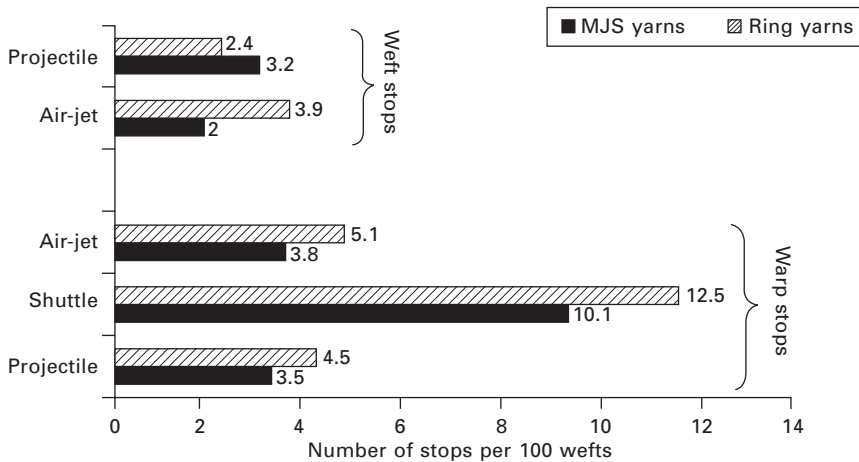

12.17 Number of stops of MJS yarns and ring spun yarns during weaving.

high production speed of the spinning machines: up to 500 m/min for MVS. Air-jet yarns are spun about two to three times faster than rotor yarns and about 20 to 30 times faster than ring yarns, depending on the yarn count. The flexibility of air-jet spinning is related to the variety of the methods developed. Different jet arrangements, jet geometries and constructional varieties have led to the production of yarns with differences (though limited) in yarn count, structure and properties as well as types of fibre spun. Air-jet spun yarns have a small, but important share of the cotton/polyester yarn market. They do not compete directly with rotor yarns, as they occupy a different niche count range: air-jet spinning machines allow the production of finer yarns (up to 10 tex), compared to rotor-spun yarns.

The main limitations of air-jet spinning are related to the quality of the yarns. The biggest disadvantage is the difficulty of spinning 100% cotton yarns. Due to their particular structure and insufficient strength, air-jet yarns are restricted to lower linear densities (the strength decreases as the yarns become coarser). There are quite high requirements for the quality of the slivers, which call for a higher number of drawings or even combing of the slivers. The extra twists of the yarns, necessary to increase the yarn tenacity, are reflected in the harsh hand of the fabrics which therefore need particular optimization in finishing. The harshness of hand, however, limits the range of applications for air-jet fabrics. It can be expected that Murata Vortex Spinning (MVS) will overcome to a certain level the limitations of the air-jet spinning method, at least in the quality of cotton-rich blends.

## 12.9 Applications of air-jet spun yarns

The application of air-jet spun yarns depends strongly on their quality and particular characteristics. Their initial application in woven fabrics was focused on cotton-rich sheeting. MVS yarns broaden this focus to 100% cotton sheeting as well. Other woven end-uses are twill fabrics and fleece fabrics production.

Application to knitted fabrics is spread over interlock and pique knits as well as jersey outerwear. MVS yarns are good for fleece-wear and single-knit jersey as they show less pilling and fuzz formation.

The specific structure of MVS yarns leads to a noticeable decrease of the pilling problem. The result is that MVS yarns produce fabrics suitable for suits, shirts, upholstery and curtains. The low shrinkage levels make the yarns very appropriate for linings and beltings.

High twist yarns, especially from cotton-rich blends, increase the water absorption of the fabrics. Therefore air-jet spun yarns are very good for summer shirt fabrics and bed linen.

## 12.10 Future trends

Air-jet spinning is the modern alternative to ring and rotor spinning. This is the fastest spinning technology for staple fibre yarn production.

Applications of air-jet spun yarns are anticipated to grow and therefore wider use of air-jet spinning machines is expected, mainly in the American and Asian markets rather than the European market. The European market, which is more conventional, will probably continue to have a preference for the highest quality ring spun yarns. The growth in air-jet spinning is likely to be in the cotton yarns market due to the new MVS technology, as well as in the field of long-fibre spinning (i.e. production of low-twist ply yarns). The development of these methods over the coming years will be strongly focused on improving yarn quality in order to achieve near-substitutes for ring spun yarns.

## 12.11 References

- Angelova, R.A. 1999, 'Influence of the second twisting on the properties of PLYfiL yarns', *Fibers & Textiles in Eastern Europe*, October/December, pp. 30–33.
- Angelova, R.A. 2001, *Investigation of the Air-Jet Spinning*, PhD Thesis, Technical University of Sofia.
- Angelova, R.A. 2002, 'Yarn twist prediction on the basis of flow modelling in an air-jet spinning nozzle', *2nd World Textile Autex Conference 'Textile Engineering at the Dawn of the New Millennium: an Exciting Challenge'*, Bruges, Belgium, p. 554.
- Artzt, P., Dallmann, H. 1989, 'Chancen der Verarbeitung von Baumwolle nach dem Luftspinnverfahren', *Melliand Textilberichte*, No. 5, pp. 318–324.
- Artzt, P., Gonzelmann, M. 1989, 'Verarbeitung von Viskose und Modal in Mischung mit Baumwolle nach dem Air-Jet Spinnverfahren', *Melliand Textilberichte*, No. 11, pp. 821–826.
- Baig, S., Akhtar, N.A., Ahmad, I. 2007, 'Impact of multiple blend ration and different spinning system on the quality of jute yarn', *J. Quality and Technology Management*, <http://www.pu.edu.pk/iqtm/journal/currentissue.htm>
- Barella, A., Bardi, X., Castro, L., Manich, A., De Castellar, M. 1993, 'Approach to the study of yarn hairiness variability', *Melliand Textilberichte*, No. 3, pp. E85–E90.
- Basal, G. 2003, *The Structure and Properties of Vortex and Compact Spun Yarns*, PhD Thesis, North Carolina State University.
- Basal, G., Oxenham, W. 2003, 'Vortex spun yarn vs. air-jet spun yarn', *Autex Research Journal*, Vol. 3, No. 3.
- Basu, A. 1999, 'Progress in air-jet spinning', *Textile Progress*, Vol. 29, No. 3.
- Basu, A., Oxenham, W. 1992, 'The effect of fibre properties on the strength of air-jet spun yarns', *Indian Text. J.*, No. 1.
- Bergada, J.M., Valencia, E., Coll, L. 2007, 'Flow characterization in cylinders for pneumatic spinning', *Textile Research Journal*, Vol. 77, No. 2, pp. 67–76.
- Bhortakke, M.K., Nishimura, T., Matsuo, T. 1999, 'High speed yarn production with air-jet spinning – effects of some fibre parameters', *Textile Research Journal*, Vol. 69, No. 2, pp. 84–89.

- Chasmawala, R.J., Hansen, S., Jayaraman, S. 1990, 'Structure and properties of air-jet spun yarns', *Textile Research Journal*, Vol. 60, No. 2, pp. 61–69.
- Cheng, T.W. 1985, 'The discriminant of the forms of the fiber motion in flows', *J. China Textile Univ.*, Vol. 1, No. 21, pp. 1–7.
- Coll, L., García, E., Galván, F. 1992, 'Propiedades de los hilados por zunchado neumático, comparados con las de los hilados', *Bol. INTEXTER*, No. 101, pp. 23–32.
- Fischer, J. 1991, 'Tejidos de hilos retorsidos de lana peinada fabricados segun un nuevo procedimiento', *Tejeduria/Tricotaje*, No. 3, pp. 36–42.
- Georgiev, I., Angelova, R., Coll-Tortosa, L., Farres, X. 1995a, 'Wool with polyester yarns produced on the PLYfiL system – Part I', *Tekstilna Promishlenost*, No. 7/8.
- Georgiev, I., Angelova, R., Coll-Tortosa, L., Farres, X. 1995b, 'Wool with polyester yarns produced on the PLYfiL system – Part II', *Tekstilna Promishlenost*, No. 9.
- Goswami, B.C. 1998, 'New technology challenges conventional spinning systems', *ATI*, Vol. 27, No. 12, pp. 69–70.
- Grill, W. 1991, 'Woraussetzungen und Erfahrungen beim Zwirnen von PLYfiL-Garnen', *Melliand Textilberichte*, No. 2, pp. 87–94.
- Grosberg, P., Oxenham, W., Miao, M. 1987a, 'The insertion of "twist" into yarns by means of air-jets, Part I: An experimental study of air-jet spinning', *J. Text. Inst.*, No. 3, pp. 189–203.
- Grosberg, P., Oxenham, W., Miao, M. 1987b, 'The insertion of "twist" into yarns by means of air-jets, Part II: Twist distribution and twist-insertion rates in air-jet twisting', *J. Text. Inst.*, No. 3, pp. 204–219.
- Hergeth, H. 2001, 'Spinning in the new millennium', *Textile Ind.*, No. 10.
- Heuberger, O., Ibrahim, S.M., Field Jr, F.C. 1971, 'The technology of fasciated yarns', *Textile Research Journal*, No. 9, pp. 768–773.
- Kato, H. 1986, 'Development of MJS yarns', *J. Textile Mach. Soc. Japan*, Vol. 32, No. 4, pp. 95–101.
- Kaushik, R.C.D., Salhotra, K., Tyagi, G. 1993, 'Viscose MJS yarn characteristics', *Textile Asia*, No. 9, pp. 54–56.
- Krause, H.W. 1985, 'Staple-fiber spinning systems', *J. Text. Inst.*, No. 3, pp. 185–195.
- Krause, H.W., Soliman, H.A. 1989, 'Theoretical study of wrapping twist in single jet false twist spinning', *Textile Research Journal*, No. 9, pp. 546–552.
- Lawrence, C.A. 1988, 'Short-staple yarn production', *Textile Horizons*, No. 1.
- Lawrence, C.A., Baqui, M.A. 1991, 'Effects of machine variables on the structure and properties of air-jet fasciated yarns', *Textile Research Journal*, No. 3, pp. 123–130.
- Lord, P.R. 1987, 'Air-jet and friction spinning', *Textile Horizons*, No. 7.
- Lünenschloss, J., Brockmanns, K.J., Phoa, T.T. 1986, 'Cotton processing by new spinning technologies – possibilities and limits', *Int. Textile Bulletin*, No. 2.
- Ortlek, H.G., Ulku, S. 2007, 'Effects of spandex and yarn counts on the properties of elastic core-spun yarns produced on Murata Vortex Spinner', *Textile Research Journal*, Vol. 77, No. 6, pp. 432–436.
- Oxenham, W. 2007, 'Staple spinning', *Textile World*, November–December.
- Oxenham, W., Basu, A. 1993, 'Effect of jet design on the properties of air-jet spun yarns', *Textile Research Journal*, No. 11, pp. 674–678.
- Punj, S.K., Mukhopadhyay, A., Maity, T. 1997, 'Response to doubling of MJS yarns produced with varying nozzle pressure', *Indian J. Fibre and Text. Res.*, Vol. 22, No. 1.
- Rajamanickam, R., Hansen, S., Jayaraman, S. 1997a, 'Analysis of the modelling methodologies for predicting the strength of air-jet spun yarns', *Textile Research Journal*, No. 1, pp. 39–44.

- Rajamanickam, R., Hansen, S., Jayaraman, S. 1997b, 'A computer simulation approach for engineering air-jet spun yarns', *Textile Research Journal*, No. 3, pp. 223–230.
- Rajamanickam, R., Hansen, S., Jayaraman, S. 1998a, 'A model for the tensile behavior of air-jet spun yarns', *Textile Research Journal*, No. 9, pp. 654–662.
- Rajamanickam, R., Patel, M., Hansen, S., Jayaraman, S. 1998b, 'Interaction of process and material parameters in air-jet spinning', *Textile Research Journal*, No. 10, pp. 708–714.
- Rudy, J.K. 1985, 'ATME-I showcases variety of high tech spinning', *ATI*, No. 12, pp. 30–34.
- Soe, A.K., Takahashi, M., Nakajima, M., Matsuo, T. 2004, 'Structure and properties of MVS yarns in comparison with ring yarns and open-end rotor spun yarns', *Textile Research Journal*, Vol. 74, No. 9, pp. 819–826.
- Stalder, H. 1988, 'New spinning methods', *Int. Textile Bulletin*, No. 1, pp. 27–39.
- Stalder, H. 1990, 'Spinning in the 1990s', *Text. Asia*, No. 2.
- Stankov, P. 1998a, 'Modeling of tangentially injected swirl flow in pipes using two-equations turbulent model: applicability and limitations', *XIX Summer School 'Application of Mathematics in Technology'*, Sozopol, Bulgaria, pp. 184–187.
- Stankov, P. 1998b, *Three-Dimensional Turbulent Flows in Heat and Mass Transfer Processes*, Doctor of Science Thesis, Technical University of Sofia.
- Thomas, U. 1988, 'Short staple spinning in the year 2000', *Textile Month*, June, pp. 19–28.
- US Patent 3,079,746, 5 March 1963.
- US Patent 5,528,895, 25 June 1996.
- Walraf, E. 2001, 'Sliver preparation for air-jet spinning', *Rieter Link*, No. 3.
- Witczak, D., Golański, J. 2007, 'Air flow in the air-jet false-twist spinning chamber', *Fibres & Textiles in Eastern Europe*, Vol. 15, No. 3, pp. 45–48.
- Wulfhorst, B. 1986, 'State of the art in the development of non-conventional spinning methods', *Chemiefasern/Textilindustrie*, Vol. 36/88, December, pp. 1025–1033.
- Yu, C., Zhang, W. 1996, 'The distribution of air flow field in the nozzle of an air-jet spinning machine', *J. China Textile Univ.*, Vol. 2, No. 42, pp. 47–56.
- Zeng, Y.C., Yu, C.W. 2003, 'Numerical simulation of air flow in the nozzle of an air-jet spinning machine', *Textile Research Journal*, Vol. 73, pp. 350–356.
- Zeng, Y.C., Yu, C.W. 2004, 'Numerical simulation of fibre motion in the nozzle of an air-jet spinning machine', *Textile Research Journal*, Vol. 74, pp. 117–122.

---

R. A. ANGELOVA, Technical University of Sofia, Bulgaria

**Abstract:** Hollow spindle spinning is a technology developed as a one-stage process for production of fancy yarns. It is also used for the production of wrap yarns, which are bi-component yarns, made of a core of parallel fibres, bound together by a wrapper or binder that is usually a filament yarn. This chapter begins with a review of the history of hollow spindle spinning developments and then describes the fundamental principles of the process. The details of various structures of both fancy and wrap yarns and their application are presented, special emphasis being given to the assessment of the quality of wrap yarns. The chapter then discusses the advantages and limitations of hollow spindle spinning and the future trends in its development.

**Key words:** hollow spindle spinning, hollow spindle machines, fancy yarns, wrap yarns.

### 13.1 Introduction

Hollow spindle spinning is a method for the production of both plain and fancy yarns. Although the two types of yarn can be spun on the same spinning system, the resultant yarn structures are different and have different properties and applications. The hollow spindle spinning method was invented in Bulgaria during the early 1970s by Georgy Mitov, who worked at the Bulgarian Institute of Textiles. The hollow spindle technology was called 'Prenomit'. However, there are several patents preceding this invention that describe the use of a hollow spindle for twisting, in particular German Patent 601,637 from 1932, British Patent 572,244 from 1943 and Czechoslovakian Patent 124508 from 1956 (Mitov *et al.* 1986). However, scrutiny of these patents (including some from the 1960s and 1970s) shows that they did not deal with the design of the hollow spindle itself, but mainly with the combination of a hollow spindle and other devices. The purpose of these combinations was to extend the materials that could be used for spinning, and to increase the productivity of the spinning system or improve the structure and the properties of the spun yarns.

The primary idea of G. Mitov was to integrate the two stages of the classical ring technology for production of fancy yarns by only one stage, by using the new 'hollow spindle' device (Mitov *et al.* 1986). In conjunction with this idea the replacement of the yarn twist by wrapping of a filament around the

drafted strand of parallel fibres resulted in a new, fasciated structure, which was called a 'wrap yarn' (the term 'parallel yarn' is also used) (Lawrence 2005). Four different Prenomit technologies were developed: ON-1, OF-1, PE-3 and PR-3, used for the manufacture of both wrap (plain) and fancy yarns (Mitov *et al.* 1986).

The first successful demonstration of the Prenomit machine in 1973 was followed by rapid development of hollow spindle technology by various other machine manufacturers. Gemmill & Dunsmore in the UK and Saurer Alma in Germany acquired licences for production of hollow spindle machines. The ITMA'75 International Textile Machinery Exhibition is considered to be the onset of commercialization of hollow spindle technology as a wide range of commercial machines available were exhibited there for the first time (Angelova 2003).

An important stage in development of the hollow spindle spinning was the appearance of the Coverspun method, introduced in 1979 by the US company Leesona Corporation. The Leesona concept was the use of a soluble filament (polyvinyl alcohol) for wrapping the bundle of parallel fibres (Angelova 2003) so that after weaving, the filaments were dissolved to produce the so-called 'HiLoft' terry fabrics. The result was the production of 100% cotton terry fabrics with higher softness and sorption abilities, constructed by almost parallel fibres.

One of the main producers of hollow spindle machines today is the German company Suessen, which developed the following series of machines: the Parafil 1000K for cotton warp yarns, the Parafil 1000S for worsted yarns and the Parafil 2000 for semi-worsted yarns (Suessen 1999).

The state-of-the-art of hollow spindle technology largely concerns two factors: the productivity of the spinning machines and the range of applications of the yarns produced. Currently the upper limit of delivery speed of hollow spindle spinning is 150–200 m/min, depending on the length of the fibres and the type of yarn: wrap yarns or fancy yarns. The weight of the hollow spindle together with the pirn is up to 410 g, while the rotating speed of the spindle is 35,000 rev min<sup>-1</sup> (Suessen's Parafil). The linear density of the filaments used for wrapping varies from 13 to 167 dtex (Suessen 1999).

Application of hollow spindle spun yarns is quite broad: from knitted garments, including warp-knitted, to woven fabrics for outer garments, terry fabrics and floor coverings.

## 13.2 Basic principle of hollow spindle spinning

### 13.2.1 General remarks

The principle of hollow spindle spinning is illustrated in Fig. 13.1. A sliver or roving is drafted by a roller drafting system (1) and enters the hollow spindle (2). A pirn of filament is mounted on the spindle so that the filament

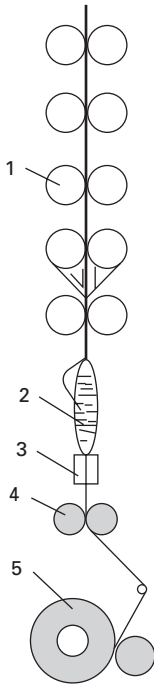

13.1 Principle of hollow spindle spinning.

also enters the axial inlet of the hollow spindle. Near its exit the hollow spindle has a pin-type false-twister device (3); there are also methods that use a false-twister on the top of the hollow spindle (Lawrence 2005). One revolution of the hollow spindle imparts one twist (i.e. wrap) of the wrapper filament around the core of parallel fibres. The yarn is drawn out from the hollow spindle due to the action of the delivery rollers (4) and then it is wound onto a bobbin (5).

The false-twister plays a very important role. After the drafted strand of parallel fibres issuing from the drafting systems enters the axial inlet of the hollow spindle, it is wound around the false-twister. Thus, the false-twister imparts false twist to the fibre ribbon and prevents it from encountering additional (uncontrolled) drafting inside the spindle. The filament also moves inside the hollow spindle and passes around the false-twister. However, the filament does not receive any twist, as the rotation speed of the pirn (with the filament) and that of the hollow spindle are equal.

The production speed of the hollow spindle machines is 3–5 times higher than the production speed of ring spinning frames (Suessen 1999). The essential reasons for this result are:

- The absence of ballooning and the resulting centrifugal forces, acting on the yarn during the spinning process

- The absence of a traveller and the resulting problems of localized heating of the traveller
- The fineness of the wrapper, which allows a longer length of filament to be wound on a pirn with relatively small dimensions and weight
- The relatively small air resistance of the wrapper during unwinding from the pirn compared to that of the ring spinning balloon. This decreases the energy consumption.

In the late 1980s hollow spindle spinning reached the peak of its development, which was characterized by the following features (Oxenham 1984, Lord 1987, Wulfhorst 1987, Angelova 2003):

- *Availability of two different types of hollow spindle unit:*
  - With a false-twister mounted at the axial outlet of the hollow spindle: this provokes wrapping of the filament around the drafted ribbon after the hollow spindle.
  - With a false-twister mounted at the axial inlet of the hollow spindle (i.e. a hole in the spindle): this provokes wrapping of the filament around the drafted strand in the inner part of the spindle, after the inlet.
- *Strong dependence of the hollow spindle's rotational velocity on its weight (with the filament):*
  - 35,000 rev min<sup>-1</sup> for a spindle weight of 230 g
  - 30,000 rev min<sup>-1</sup> for a spindle weight of 250 g
  - 25,000 rev min<sup>-1</sup> for a spindle weight of 270 g.
- *High delivery speed.* The delivery speed of the hollow spindle process reached 200 m/min.
- *A variety of drafting arrangements.* Single-zone and two-zone drafting arrangements are used for production of wrap and fancy yarns from short and long staple fibres. The two-zone drafting unit of the Spinmack machine of James Mackie (shown for the first time at ATME-I '82) demonstrated drafting of slivers with fibre lengths between 60 and 220 mm, with a total drafting of up to 250 times. This development allowed the elimination of the third passage drawing machines and even the roving process from the production line for spinning worsted and semi-worsted yarns. At the same time it made possible the spinning of yarns with a wide range of linear densities from the same count (ktex) of sliver.
- *Automatic stop of the hollow spindle at break.* Gemmill & Dunsmore demonstrated the automatic stop of each spinning unit on a machine when a break of the drafted ribbon or the filament occurred.

Today, hollow spindle spinning methods can be grouped as follows:

- In relation to the yarn spun:
  - Methods for production of warp spun yarns

- Methods for production of fancy yarns.
- In relation to the drafted product:
  - Methods for spinning directly from a sliver
  - Methods for spinning from a roving.

The hollow spindle method is capable of spinning a wide range of fibre types in both wrap and fancy yarns. Depending on the particular end-use the fibres can be natural (mainly wool and cotton), man-made (acrylic and polyester) and blends of natural and man-made fibres. The wrapping thread could be a staple fibre yarn, but it is mainly an acrylic or polyester filament.

Figure 13.2 summarizes the hollow spindle spinning methods that were invented and have been used for industrial production of wrap and fancy yarns (Angelova 2003).

### 13.2.2 Spinning of fancy yarns

The commercial significance of fancy yarns increases continuously due to the abundance of possible effects and their aesthetic influence on the look of knitted and woven fabrics. The hollow spindle method is one of the four methods, together with ring spinning, the combined system and the chenille method, for production of fancy yarns (Gong *et al.* 2002)

The classical ring system for production of fancy yarns includes two stages. The twisting of the core and the effect component is done during the first stage. The second stage involves the twisting of the binder around the first two components, thus fixing the effects and giving additional strength to the final yarn.

Fancy yarns produced by using hollow spindle machines have a similar look to yarns produced with ring twisting and the combined system, but their structure and properties are different. Similarly to the ring system, the production of a fancy yarn with a hollow spindle requires three different

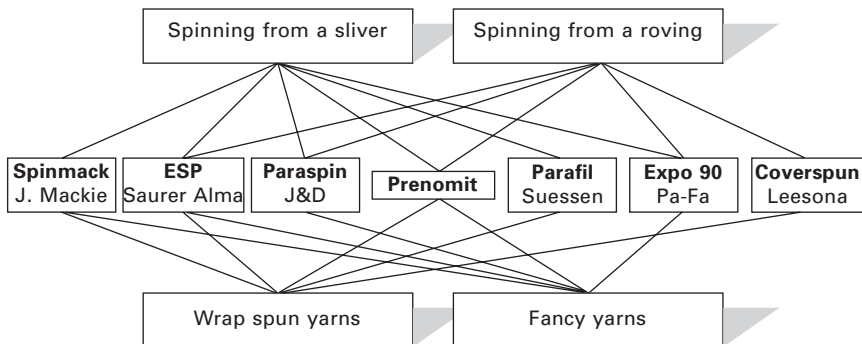

13.2 Hollow spindle spinning methods.

components: core, effect and binder. The core thread forms the base of the structure onto which the effect thread produces the geometrical shape or profile of the effect, which can be loops, knops, snarls, etc. (Fig. 13.3).

Hollow spindle spinning gives the possibility of integrating the two stages of the traditional ring system into one. Thus, the core and the effect components pass through a roller drafting unit (though having different paths) and enter the axial inlet of the hollow spindle. The binder is, in general, a filament, which is wound onto the pirn, placed on the hollow spindle. The core and

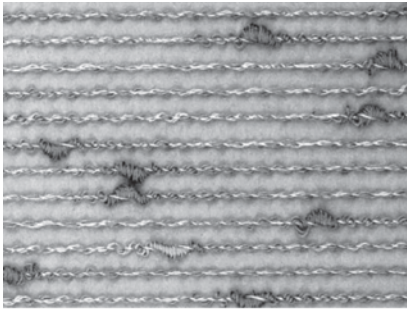

Knops

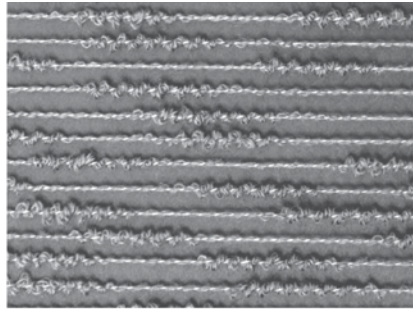

Caterpillars

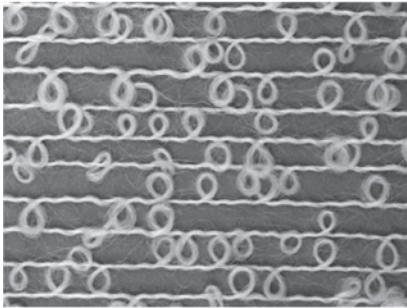

Loops

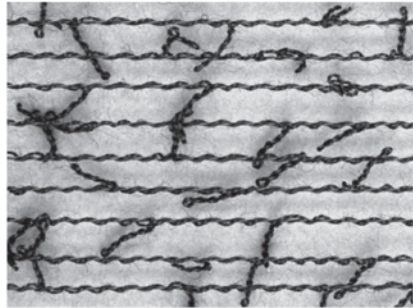

Snarls

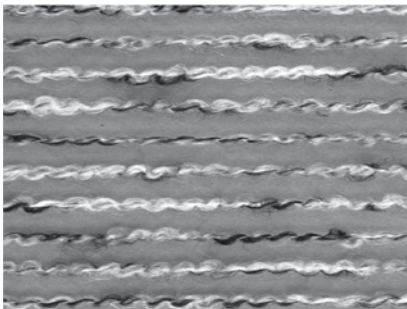

Frisé

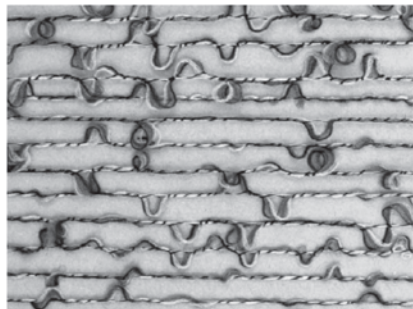

Ondé

13.3 Different type of effect yarns.

the effect components are not twisted in the hollow spindle or have very small twist, compared to the twist of the filament around them (Gong *et al.* 2002, Petrulytė and Petrulis 2004). The wrapping of the two components (core and effect) by the filament to create a fasciated structure leads to the result that most of the elements in the fancy yarn stay parallel. The wrapping filament is the only one that imparts the necessary cohesion – Fig. 13.4.

### 13.2.3 Spinning of wrap yarns

The original method for producing wrap yarns is the Prenomit ON-1. The specific structure of the wrap yarns was obtained when the effect component during the production of a fancy yarn was omitted. Thus, only the parallel fibres of the drafted ribbon were wrapped by the binder – Fig. 13.5. The

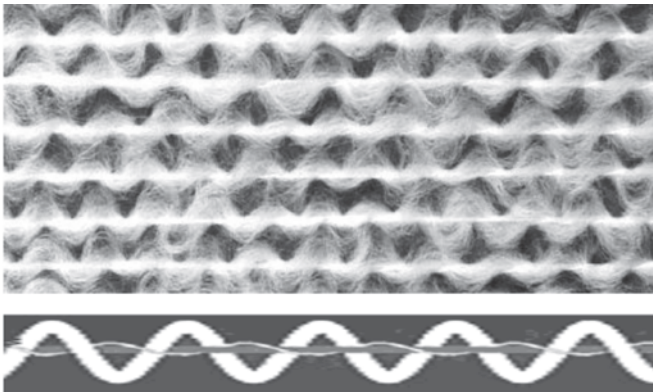

13.4 The fasciated structure of bouclé yarns made by using a hollow spindle machine.

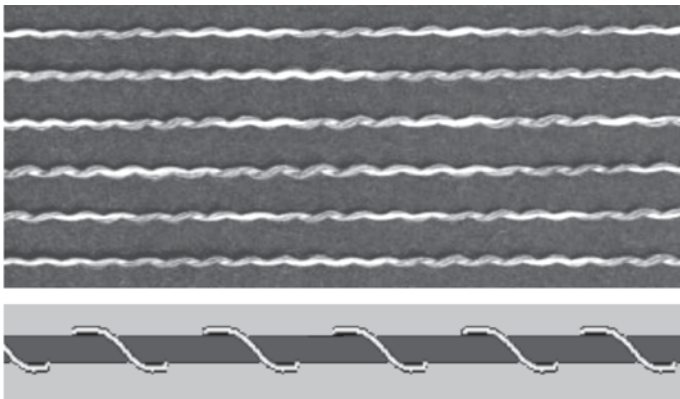

13.5 Wrap yarns made by using a hollow spindle machine.

new structure attracted the attention of producers and researchers from all over the world, which resulted in fast development of the wrap yarns' niche (Li *et al.* 2002). The properties of wrap yarns such as high tenacity, good regularity, softness and bulkiness allowed them to be used in woven and knitted fabrics, including brushed fabrics and floor coverings (Weisser and Czapay 1983, Yang and Li 1990).

### 13.3 Structure of yarns made by hollow spindle machines

#### 13.3.1 Structure of fancy yarns

The process of production of fancy yarns by using hollow spindle is much faster and lower in costs compared to traditional ring twisting. However, the resulting structure of the yarns is different. As explained earlier, the binder fixes the geometrical shape or profile of the effect thread around the core thread; there is no actual twist between the core and the effect component. The binder (the wrapping filament) is the only component responsible for the good cohesion of the fancy yarn's structure and for the yarn's strength. Therefore the combination of the core and effect components may be described as an 'intermediate product' in the strict traditional understanding of fancy yarn spinning. This product may have:

- a classical structure, made by combining one core thread and one effect thread; or
- a complex structure, made by a combination of two core threads and one effect thread, or one core thread and two effect threads.

The specific structure of hollow spindle fancy yarns has the major disadvantage that if the binder breaks during knitting or weaving, the yarn is totally destroyed, as there is no cohesion between the core and the effect components.

The properties of hollow spindle fancy yarns are influenced by the material of the three components and the spinning parameters (Ragaišienė and Petrulytė 2000, Petrulytė 2001). Spinning parameters like the rotational velocity of the hollow spindle, the velocity of the supply of the effect component, and the delivery speed of the fancy yarn, influence the structural effects.

Testore and Minero (1988) published a study on the fundamental parameters that influence fancy yarn types and properties. They found that the great difference in the feeding speed of the core and the effect component required higher twist levels for wrapping. However, twist level considerably influences the handle, and therefore has to be chosen to meet the required tactile aesthetics as well as enabling the effect profile to be achieved. Zhu and Oxenham (1994) continued the fundamental studies, demonstrating

that in the case of bouclé fancy yarns, the increase of the production speed decreased the height of the effect and increased its irregularity.

The need to investigate fancy yarn structures in general and build theoretical models of these structures was initiated by the introduction of new methods for their production and the increased interest in the use of hybrid yarns (Testore and Guala 1989, Pouresfandiari 2003, Petruitytė and Petrusis 2004). The relationship between manufacturing parameters and the structure of fancy yarn produced by the combined ring–hollow spindle spinning system were studied by Su *et al.* (1992). Wang and Huang (2002) concentrated their work on investigating and modelling the parameters of fancy yarns with slub effects spun on rotor spinning frames, and Pouresfandiari (2003) investigated the structure and properties of rotor loop fancy yarns. The structures of different types of fancy yarn were investigated in studies reported by Drean and Renner (1993), Grabowska (2000), Nergis (2002), and Petruitytė and Petrusis (2004).

Belov *et al.* (1999) introduced a theoretical analysis of the modelling of yarns with loops and snarls. The fancy yarns were treated as elastic objects, but the interaction between the contracting parts of the fancy yarns was not taken into consideration. Geometrical models of the structure of fancy yarns and a theoretical method for predicting the coil length of the binder in such yarns have been reported by Petruitytė (2003) and Petrusis and Petruitytė (2003). An extensive analysis comparing the proposed theoretical models of different fancy yarn structures and their applications was also undertaken by Petruitytė and Petrusis (2004).

Petruitytė (2008) investigated the profiles of periodic effects such as gimp, loop, and knop, loop and knop sequences, and combinations of them, produced on a Prenomit hollow spindle machine. Several mathematical models were employed and it was found that the model developed for the loop–gimp effect combination enabled reasonable predictions of profile geometries and could be used in the designs of other fancy yarns.

### 13.3.2 Structure of wrap yarns

Wrap yarns are characterized by their specific structure: a core of parallel yarns, wrapped together by the wrap thread. The wrap thread can be either filament or staple fibre yarn, but more frequently filaments are used. Similar characteristics as for ring-spun yarns can be used. Thus, twist = wraps, twist coefficient = wrap coefficient, critical twist coefficient = critical wrap coefficient. The reason is that one rotation of the hollow spindle imparts one wrap by the filament component around the core fibres, which is similar to one turn of twist in the ring spinning process. However, as the wrapping of the filament is the specific feature of the method, the term ‘wrapping pitch’ (or ‘coil pitch’) is also used as a characteristic feature of wrap yarns,

including fancy yarns. The wrapping pitch  $t$  is dependent on the wraps per unit length and is the measured distance between two nearby wraps of the wrapping component – Fig. 13.6.

The bi-component structure determines the properties of wrap-spun yarns. The type of core fibres and the required linear density of the yarn determine the selection of a particular wrapper. Suessen claims that the amount of wrapper used should be 2–5% by weight (Suessen 1999). However, the wrapping filament in a 20 tex warp yarn can account for about 10% of the yarn count, which formally classifies the yarn as a blended yarn (Lord 1987). Obviously, with the increase of the yarn's linear density the participation of the wrapper decreases and it can be less than 1% in the case of a 100 tex yarn.

Slight core fibre disorientation along the wrap yarn axis can appear, due to the frictional contact between the drafted strand and the axial inlet of the hollow spindle (Behery and Nunes 1986). A spiral-shaped structure of yarn spun with a high degree of wraps was noticed in the study of Xie *et al.* (1986a) as well. Actually, the tortuous structure of the wrap yarns is strongly influenced by the false twisting (Miao and Chen 1991). The false twister facilitates the spinning, but it introduces additional variations to the yarn's appearance and properties. An analysis of the influence of the false twister on the structure of wrap yarns was presented in Miao *et al.* (1994). It was found that wrap yarns spun with a false twister have a tortuous structure, while wrap yarns spun without a false twister are smooth and regular – Fig. 13.7.

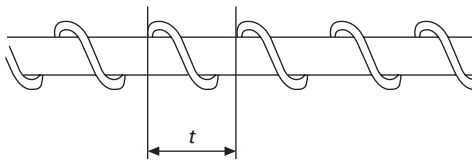

13.6 Wrapping pitch.

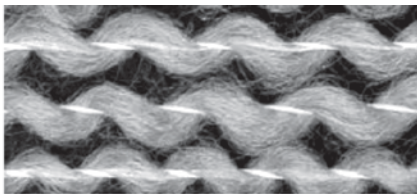

(a)

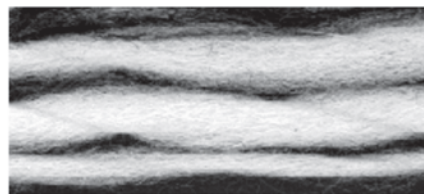

(b)

13.7 Wrap yarn structure under a microscope: (a) yarn spun with a false twister; (b) yarn spun without a false twister.

### 13.4 Assessment of the quality of wrap yarns

One of the main advantages of wrap spun yarns over ring spun yarns is that finer yarns can be spun from coarse fibres. The specific bi-component structure of wrap yarns requires fewer fibres in the yarn cross-section to obtain the necessary strength of the yarn.

#### 13.4.1 Mechanical properties of wrap yarns

The presence of a core of twistless fibres and a filament as a wrapper makes the wrap-spun yarn structure considerably different from the structure of ring-spun yarns. Although the core of fibres dominates as a percentage of the yarn structure, the wrapper plays an important role with regard to the mechanical properties of the resultant yarn (Xie *et al.* 1986a, Brydon 1987, Angelova and Todorova 1999, Grabowska 2000). The influence of the elastic properties of the wrapper and the degree of wraps on the breaking strength and elongation is independent of all other process parameters. The type of wrapper (monofilament, polyfilament, texturized polyfilament, etc.), linear density and its elastic modulus strongly influence the yarn's breaking strength (Lawrence *et al.* 1985, Jakowski and Grabowska 1998, Angelova 2002).

Comparison between the mechanical properties of ring and wrap yarns shows that the type and linear density of the wrapper as well as the wrapping step have a much more significant influence on the mechanical properties of the wrap yarns than the linear density of the wrap yarn itself and the properties of the core fibres, as in the case of ring spun yarns (Goswami *et al.* 1976, Xie *et al.* 1986a, 1986b).

There are three mechanisms of tensile failure that are predicated by the presence of core and wrapper components:

- Mechanism I: tensile failure due to breaking of the wrapper
- Mechanism II: tensile failure due to slipping of core fibres
- Mechanism III: tensile failure due to breaking of core fibres.

The strength of the wrapper therefore controls the strength of the wrap yarn but only in the case of Mechanism I. Figure 13.8(a) shows part of the wrapper of length  $L$ , subject to the action of strain force  $P$ . Due to the strain force  $P$  the wrapper increases in length, at the same time decreasing in cross-section. The wrapper breaks when its tension reaches a critical value  $\sigma_{br}$  (which corresponds to strain force  $P_{br}$ ).

The breaking of the wrapper is similar when the wrapper is a component of a wrap spun yarn – Fig. 13.8(b). However, the strain force which leads to a break of the wrapper is  $P_{br}$ , which can be defined as:

$$P_{br} = \frac{P_{br}}{\cos \alpha}$$

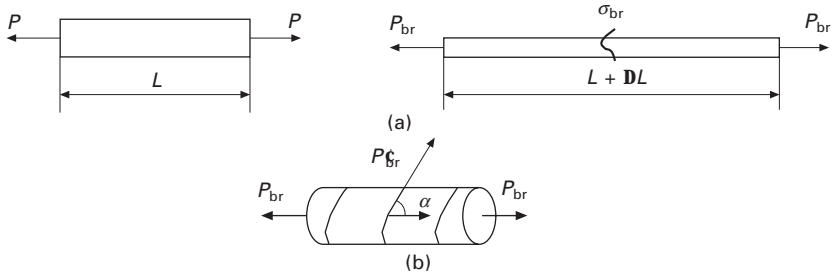

13.8 Breaking mechanisms of wrap spun yarn: (a) breaking of the wrapper; (b) breaking of the wrap yarn.

where  $\alpha$  is the angle between the two forces  $P_{br}$  and  $P_{br}$ .

Mechanism I is the most unusual case in the breakage of wrap yarns. This hypothesis was proved by theoretical and experimental investigations (Xie *et al.* 1986a, Angelova 1999). The other two breaking mechanisms do not depend on the mechanical properties of the wrapper. For these situations the strength of the wrap-spun yarn will strongly depend on the length of the core fibres, the friction forces between the core fibres and the compression tension exercised by the wrapper on the core fibres.

In order to predict the mechanical properties of wrap-spun yarns, Xie *et al.* (1986a, 1986b, 1986c) derived mathematical relationships between the structural parameters and the tenacity of the wrap yarns, based on the assumption of an ideal cylindrical yarn structure. More recently, Choi (1991) developed a computer simulation procedure to predict the tensile properties of wrap yarns. Jakowski and Grabowska (1998) also developed a model based on the dependencies from the work of Xie *et al.* (1986a, 1986b, 1986c), but corrections were made in order to describe the more frequently observed tortuous (i.e. gimp) structure of the wrap yarns.

### 13.4.2 Comparison between wrap yarns and two-fold ring yarns

Wrap spun yarns demonstrate several advantages in comparison with two-fold worsted and semi-worsted yarns. A consensus of opinion is that the production of two-folded ring spun yarns, particularly fine worsted yarns, is 'costly extravagance' from the point of view of energy consumption, staff costs, space requirements and initial capital investments ('Friction spinning', interview with G. Spire, 1983).

The spinning of fine worsted yarns necessitates a higher level of twist in order to reach the required yarn strength. However, the twist levels decrease the bulkiness of yarns and increase irregularity and twist liveliness. Consequently, doubling (i.e. ply twisting) of the single yarns is an obligatory stage in the

production. Certainly, there has been no definitive yarn development that can fully replace folded ring spun yarn production, but every technology that offers alternatives to these yarns (like Sirospun, Solospun or wrap spinning) is the subject of commercial interest and product development.

The properties of wrap spun yarns could be qualified as very similar to those of ring spun yarns (Angelova 2003). Indeed, the strength of wrap yarns can be controlled through the wrapping pitch, and their evenness is similar to or even better than the evenness of ring spun yarns (due to the high velocity of the drafting system). The absence of twist in the core of wrap yarns leads to lower elongation at break, compared to ring spun yarns. Due to their higher bulkiness, wrap yarns may be preferred to ring spun yarns in order to lower production costs during weaving and knitting. The lower values of twist liveliness of wrap yarns make them potential substitutes for two-fold ring spun yarns in some specific applications.

Figures 13.9 to 13.11 compare the properties of wrap spun yarns with those of worsted ring spun yarns (Angelova 2001). The ring yarns and the core of

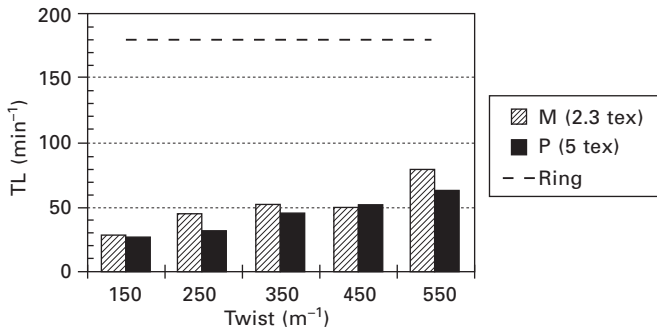

13.9 Comparison between wrap yarns and two-fold ring spun yarns: twist liveliness, TL.

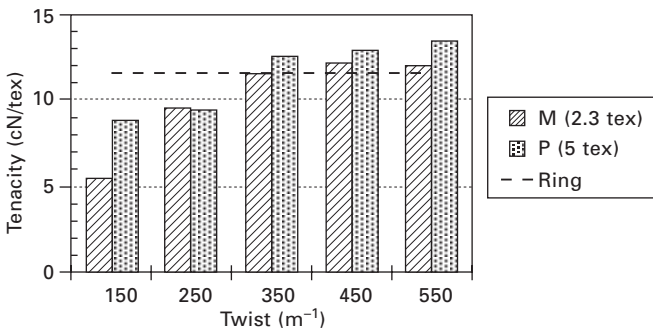

13.10 Comparison between wrap yarns and two-fold ring spun yarns: tenacity.

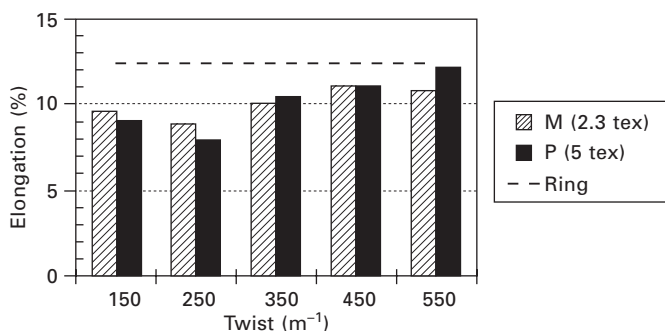

13.11 Comparison between wrap yarns and two-fold ring spun yarns: breaking elongation.

the wrap yarns were made of a blend of wool and acrylic fibres (40/60%). Two types of polyester filaments were used as wrappers: monofilament (2.3 tex) and polyfilament (12 monofilaments, 5 tex). The 40 tex wrap yarns were made on the Yantra PKVE (Prenomit) spinning machine at 150, 250, 350, 450 and 550 tpm, while 20  $\times$  2 tex ring spun yarns were spun at 550 tpm and ply-twisted at 570 tpm.

Figure 13.9 shows that the twistless core of the wrap yarns gave very low values of twist liveliness, compared to the ring yarns, though the increase of wraps led to very slight increases in liveliness. The strength of the wrap yarns was quite similar to that of the ring spun yarns (Fig. 13.10). As expected, the elongation of the wrap yarns was lower due to their specific structure (Fig. 13.11).

### 13.5 Application of hollow spindle spun yarns

The hollow spindle method is suitable for production of wrap and fancy yarns with linear density between 15 and 1500 tex from all types of natural and man-made fibres. The broad applications of both wrap and fancy yarns show the abilities of the method for meeting the needs of the market. The economic advantages in production of medium coarse and coarse yarns have led to significant use of hollow spindle spinning machines in this market niche.

Wrap-spun fancy yarns are used in knitted and woven fabrics mainly for aesthetic purposes. Traditionally, fancy yarns were used to create natural-looking items, many of them in rustic style. Nowadays fancy yarns are used by designers to create new decorative effects and new fashion styles. Due to the importance of fancy yarns for the production of woven and knitted apparel, *haute couture* fashion, hand-knitted garments, carpets, upholstery, curtains, wallpapers, etc., several attempts have been made to investigate the

structure of fancy yarns and its dependence on the technological parameters during hollow spindle spinning.

The appearance of bouclé yarns in both knitted and woven fabrics was discussed in the paper of Mole and Knox (1989). The study showed that the rib pattern had a rigid handle and the profile of the bouclé yarn was quite hidden. With knitting it was found that the bouclé effect was more visible on the back of the fabric. The properties of plain knitted fabrics made of bouclé yarns were studied in the work of Nergis *et al.* (2004). A significant difference between the thickness of the fabrics knitted from fibre-dyed yarns and that from bobbin-dyed yarns was observed.

A further study (Nergis and Candan 2006) involved the physical and dimensional properties of plain jersey and rib fabrics from bouclé yarns, produced on a combined fancy spinning machine. The use of fancy yarns (with flames) as weft threads in woven fabrics and the final appearance of the fabric were investigated by Rentzsch (1989). Computer simulation techniques were used to predict how the woven pattern would look and to investigate the possibilities of suppressing the rising of the pattern figures. The design of hollow spindle fancy yarns for woven and knitted fabrics for clothing and decorative textile end uses was reported by Ragaišienė and Petruolytė (2003).

One important advantage of wrap yarn is evident from its use as the pile yarn to produce cut-pile fabrics. The core fibres, having no twist, form extremely uniform piles on the front side of the fabric structures. Long-term studies of the Carpet Research Institute in Aachen have shown that wrap yarns are very appropriate for use in pile carpets. Moreover, it was found that 30–40 fibres in the yarn cross-section are enough to form a stable yarn with the required strength (Angelova 2003).

In this respect hollow spinning, among the modern spinning methods, can produce the finest yarn count owing to the minimum number of fibres in the yarn cross-section. Figure 13.12 shows a comparison between ring, rotor, air-jet, friction and wrap yarns: the minimum theoretical value of 56 fibres in the cross-section of a ring yarn is taken as 100% (Angelova 2003).

### **13.6 Advantages and limitations of hollow spindle spinning**

The hollow spindle spinning method shows great flexibility, as it may be used for the production of both fancy and wrap spun yarns, processing all types of natural and man-made fibres. A wide range of fancy yarn profiles is possible and the use of these fancy yarns has led to new designs and styles in simple fabric structures. Therefore it is no longer necessary for designers of woven and knitted fabrics to create complex fabric structures in order to obtain 'new look' fabrics and apparel.

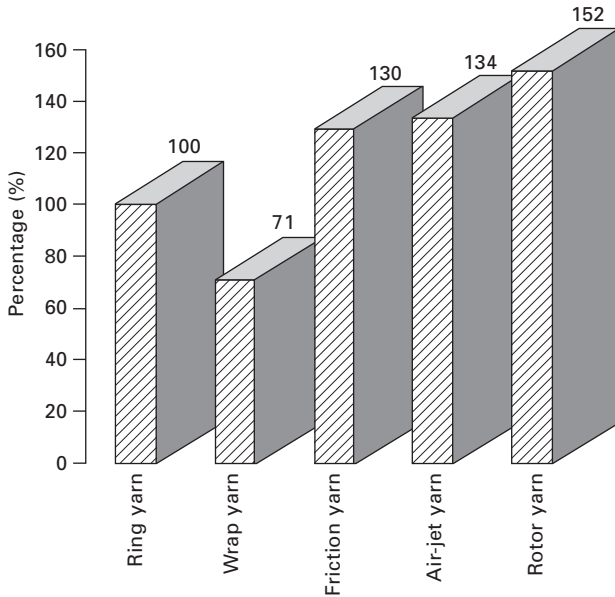

13.12 Relative comparisons between modern spinning methods: number of fibres in the yarn cross-section.

However, the fundamental disadvantage of hollow spindle fancy yarns is the very different structure of these yarns from the classical ring-twisted yarns. The lack of twist in combining the base (or core) and effect threads in the fancy yarns produced on hollow spindle machines can result in the yarn breaking more easily than in the conventional twisted structure.

Nevertheless, in the simple wrap spun form, they have greater evenness and strength and lower twist liveliness than ring spun yarns. Wrap yarns can be produced with a very low number of fibres in the yarn cross-section, thus finer yarn counts can be produced from coarse fibres, but the economic disadvantages of energy and filament costs when spinning finer wrap yarns are reasons why wrap yarns are produced with largely coarse counts.

Wrap yarns can be used instead of twisted worsted yarns to reduce production costs. The main advantage of wrap yarns is shown in pile fabrics, due to the lack of twist in their core. The main disadvantages of hollow spindle wrap yarns are related to their bi-component structure. The presence of a wrapping filament changes the appearance of the yarn and in some fabric structures the higher brilliance of the filaments is unacceptable. The elongation at break of the wrap fibres is lower than in ring spun yarns.

The hollow spindle spinning concept has been applied to other novel yarn production developments such as SAWTRI technology (Brydon 1987). This basically is a retrofit of hollow spindle units to a woollen card. The woollen

yarns showed very good quality and the resulting fabrics had a look and properties very similar to those of the woollen yarn fabrics.

Compared to other modern spinning technologies such as rotor, air-jet and friction spinning, hollow spindle spinning has the disadvantage of lower production speed. This is because higher rotational velocities of the hollow spindle are still not possible. Examples of the main areas for increased efficiency of hollow spindle machines are:

- Increase in the amount of filament (or wrapping yarn) on the pirn of the hollow spindle, in order to greatly reduce downtime in replacing empty pirns
- Use of drafting systems with high drafting ratio to enable sliver feed rather than roving feed
- Increase of the yarn package weight (up to 6 kg), to reduce the frequency of doffing.

An interesting possibility for increasing production speed was demonstrated in the Mackie Spinmack hollow spindle machine ('Friction spinning', 1983). Two hollow spindles were placed in tandem so that each spindle gave half the required wraps per unit length. The production speed could then be almost doubled when the spindles had the same direction of rotation. If the spindles rotated in different directions, they created wrap yarns with extremely low twist liveliness.

### 13.7 Future trends

The trend in hollow spindle spinning developments over the last decade is set to continue:

- Application of new materials for hollow spindle construction in order to reduce the weight and to increase the amount of the wrapping component on the pirn
- Slow progress in further extending the field of application for hollow spindle yarns, though this is expected to lead to better acceptance of fancy yarns than of wrap yarns.
- Developments of finishing treatments for improved appearance of the fabrics, woven or knitted, made from straight wrap yarns.

Hollow spindle spinning has reached a position in its development that can hardly be followed by further revolutionary changes. The main challenges of the method are related to its efficiency, as in the case of the ring spinning method. However, potential improvements to ring spinning are much more feasible than for hollow spindle spinning. The main reason is that further increases in ring spindle speeds would have a major impact owing to the worldwide acceptance of this technology compared with the hollow spindle process.

### 13.8 References

- Angelova, R. A. 1999, 'Influence of the wrapper on the mechanical properties of wrap yarns', *Proc. IV Int. Sci. Conf. EMF'1999*, Varna, Bulgaria, 15–18 September, pp. 17–22.
- Angelova, R. A. 2001, 'A comparative analysis on the properties of warp yarns and ring spun yarns: influence of the structure', *Proc. VI Int. Sci. Conf. EMF'2001*, Sozopol, Bulgaria, 19–21 September, pp. 63–68.
- Angelova, R. A. 2002, 'On the mechanical properties of wrap yarns', *Proc. VII Int. Sci. Conf. EMF'2002*, Varna, Bulgaria, 18–20 September, pp. 209–217.
- Angelova, R. A. 2003, 'Hollow spindle spinning: present status and future development', *Tekstil Obleklo*, No. 6, pp. 13–18.
- Angelova, R. A., Todorova, G. 1999, 'Method for theoretical assessment of the strength of wrap yarns', *Proc. Scientific Session of NTS Mashinostroene*, Sofia, 1–2 July, pp. 312–317.
- Behery, H. M., Nunes, M. F. 1986, 'The structure, tensile properties, and morphology of failure of wrapped yarns', *J. Textile Inst.*, Vol 77, pp. 386–402.
- Belov, E. B., Lomov, S. V., Truevtsev, N. N., Bradshaw, M. S., Harwood, R. J. 1999, 'On the problem of fancy yarn modelling', *Fibres and Textiles in Eastern Europe*, Vol. 7, No. 2, pp. 32–34.
- Brydon, A. G. 1987, 'Wrap spinning of woolen yarns', *Textile Month*, No. 5.
- Choi, K. F. 1991, 'Mechanical properties of wrapped yarns', *Textile Asia*, No. 4, pp. 33–37.
- Drean, J. Y., Renner, M. 1993, 'Fancy yarns through spinning or folding', *L'Industrie Textile*, June, pp. 30–35.
- 'Friction spinning and wrapping pose the main challenge', 1983, *Textile Month*, No. 3.
- Gong, R. H., Graham, R. M., Wright, R. M. 2002, *Fancy Yarns: Their Manufacture and Application*, CRC Press, Boca Raton, FL.
- Goswami, B. C., Martindale, J. G., Scardino, F. L. 1976, *Textile Yarns: Technology, Structure and Applications*, John Wiley & Sons, New York.
- Grabowska, K. E. 2000, 'Characteristics of loop fancy yarn', *Fibres and Textiles in Eastern Europe*, Vol. 8, No. 1, pp. 26–28.
- Jakowski, T., Grabowska, K. E. 1998, 'Studies of structure and strength of plain wrapped yarns', *Fibres and Textiles in Eastern Europe*, April–June, pp. 26–31.
- Lawrence, C. A. 2005, *Fundamentals of Spun Yarn Technology*, CRC Press, Boca Raton, FL.
- Lawrence, C. A., Cooke, W. D., Susutoglu, M. 1985, 'Studies on hollow spindle wrap-spun yarns', *Melliand Textilber. Int.*, Vol. 66, No. 5, pp. 320–325.
- Li, X., Zhang, J., Li, J. 2002, 'Differential-twist wrapped yarns made on a hollow spindle spinning machine', *Textile Research Journal*, Vol. 72, pp. 181–186.
- Lord, P. R. 1987, 'New yarn production systems at ITMA', *ATI*, No. 12.
- Miao, M., Chen, R. Q. 1991, 'Structural variations of hollow spindle wrap spun yarns', *J. China Textile Univ., Eng.*, E8(d3), pp. 1–8.
- Miao, M., How, Y. L., Cheng, K. 1994, 'The role of false twist in wrap spinning', *Textile Research Journal*, Vol. 64, pp. 41–48.
- Mitov, G., Konakchiev, P., Boev, K., Andonov, B. 1986, *Machines and Technologies Prenomit*, Tehnika, Sofia (in Bulgarian).
- Mole, K., Knox, K. 1989, 'The properties and uses of specific hollow spindle yarns', *J. Text. Inst.*, Vol. 80, No. 31, pp. 441–448.

- Nergis, B. U. 2002, 'Factors influencing the properties of ladder-knit fancy yarns', *Textile Research Journal*, Vol. 72, pp. 686–68.
- Nergis, B. U., Candan, C. 2006, 'Performance of bouclé yarns in various knitted fabric structures', *Textile Research Journal*, Vol. 76, pp. 49–56.
- Nergis, B. U., Iridag, Y., Candan, C. 2004, 'A study on properties of knitted fabrics from boucle yarns', *Proc. 2nd Int. Textile, Clothing and Design Conference*, Dubrovnik, 3–6 October.
- Oxenham, W. 1984, 'Showcases for new systems of yarn making', *Textile Month*, No. 2.
- Petrulis, D., Petruitytė, S. 2003, 'Predicting of coil length of components spirally arranged in complex structure yarns', *Materials Science (Medžiagotyra)*, Vol. 9, No. 2, pp. 224–227.
- Petruitytė, S. 2001, 'Formation of fancy yarns in one process with application of a complex model', *Fibers and Textiles in Eastern Europe*, Vol. 9, No. 1, pp. 24–27.
- Petruitytė, S. 2003, 'Complex structure fancy yarns: theoretical and experimental analysis', *Materials Science (Medžiagotyra)*, Vol. 9, No. 1, pp. 120–123.
- Petruitytė, S. 2008, 'Influence of technological parameters on the periodical effects of fancy yarns', *Fibres and Textiles in Eastern Europe*, Vol. 16, 3, pp. 25–29.
- Petruitytė, S., Petrulis, D. 2004, 'Comparison of different theoretical models of fancy yarns', *Materials Science (Medžiagotyra)*, Vol. 10, No. 1, pp. 89–92.
- Pouresfandiari, F. 2003, 'New method of producing loop fancy yarns on a modified open-end rotor spinning frame', *Textile Research Journal*, Vol. 73, No. 3, pp. 209–215.
- Ragaišienė, A., Petruitytė, S. 2000, 'Analysis and forecasting of properties of fancy yarns', *Materials Science (Medžiagotyra)*, Vol. 6, No. 2, pp. 99–103.
- Ragaišienė, A., Petruitytė, S. 2003, 'Design of fancy yarns with worsted and elastomeric covered components', *Materials Science (Medžiagotyra)*, Vol. 9, No. 4, pp. 414–418.
- Rentzsch, E. 1989, 'Distribution of flames in fancy yarns', *Textiltechnik*, Vol. 39, No. 9, pp. 470–474.
- Su, S. B., Yao, S. C., Lin, C. H. 1992, 'Construction and count of fancy loop yarns', *ATA Journal*, Vol. 3, No. 6, pp. 53–56.
- Suessen 1999, *Parafil, Wrap Spinning Machines*. Spindelfabrik Suessen GmbH, Germany.
- Testore, F., Guala, G. M. 1989, 'Effect yarns: properties and parameters', *J. Textile Inst.*, Vol. 80, No. 3, pp. 377–390.
- Testore, F., Minero, G. 1988, 'A study of the fundamental parameters of some fancy yarns', *J. Textile Inst.*, Vol. 74, No. 9, pp. 606–619.
- Wang, J., Huang, X. 2002, 'Parameters of rotor spun slub yarn', *Textile Research Journal*, Vol. 72, No. 1, pp. 12–16.
- Weisser, H., Czapay, M. 1983, 'Production of wrap spun yarns and ply-yarns by the wrap spinning process and use of this process in spinning and doubling', *Melliand Textilber. Int.*, No. 2, pp. 591–595.
- Wulfhorst, B. 1987, 'State of the art in the development of non-conventional spinning methods', *Chemiefasern/Textilindustrie*, Vol. 37/89, No. 12.
- Xie, Y., Oxenham, W., Grosberg, P. 1986a, 'A study of the strength of wrapped yarns, Part I: The theoretical model', *J. Textile Inst.*, Vol. 77, pp. 295–304.
- Xie, Y., Oxenham, W., Grosberg, P. 1986b, 'A study of the strength of wrapped yarns, Part II: Computation and experimental', *J. Textile Inst.*, Vol. 77, pp. 305–313.
- Xie, Y., Oxenham, W., Grosberg, P. 1986c, 'A study of the strength of wrapped yarns,

Part III: The relationship between structural parameters and strength', *J. Textile Inst.*, Vol. 77, pp. 314–326.

Yang, J., Li, Z. 1990, 'The design and production of a fabric of wrapped spun yarns', *Textile Research Journal*, Vol. 60, pp. 32–34.

Zhu, B-Y., Oxenham, W. 1994, 'Influence of production speed on the characteristics of hollow spindle fancy yarns', *Textile Research Journal*, Vol. 67, No. 4, pp. 380–387.

**Abstract:** Bringing together two ends of a freshly twisted yarn results in a balanced self-twisted two-fold yarn of twist direction opposite to that of the original yarn. The same principle is applied to produce self-twist yarn, but production of worsted yarn suffered from lack of speed, and this was a challenge to technologists. The Commonwealth Scientific and Industrial Research Organisation (CSIRO) developed a method of applying alternate twist to two strands of fibres before joining them together for self-twisting to ensure the insertion of opposite twist. This process created zones of no twist at each twist changeover. No-twist zones along the length of the self-twisted yarn are relatively weak spots, especially in an in-phase self-twisted yarn. To improve self-twist yarn strength, one of the twisted strands was deliberately made out of phase before joining the other strand. The out-of-phase self-twisted yarn is stronger because each strand's no-twist zones are supported by the twisted section of the adjacent strand. Separation of alternate twist insertion from winding on is the foundation of production of yarn at a much faster speed than with the ring spinning machine.

**Key words:** self-twist (ST) yarn, alternate, twist, in-phase, balance, no-twist zones.

## 14.1 Introduction

The production rate of conventional methods of yarn spinning is a challenge to technologists. Ring spinning is limited by factors such as the speed of the traveller, yarn tension between the front drafting roller nips and the yarn package, and the energy required to rotate the yarn package to enable twist insertion (Stalder 1982, 1984). The low productivity and high production cost of ring spinning have forced machine manufacturers and technologists to look for other methods of yarn manufacturing. A complete solution to the problem is offered by a simple concept upon which all break spinning devices are based. By introducing a break into the material between the supply package and the yarn package it is possible to introduce twist by only rotating the yarn end at the break. This process enables very high twisting speeds to be achieved without increasing power consumption. In addition, the spinning operation no longer imposes limitations on the type and size of yarn package which may be formed. Spinning speeds can be dramatically increased. Since the 1960s new spinning technologies have been developed, including open-end/rotor spinning, friction spinning, air-jet spinning, hollow

spindle and Siro spinning (discussed in other chapters in this book). The self-twist spinning method is another of these newer technologies designed to improve productivity in spinning.

All these new techniques have their strengths and weaknesses, depending on the type of fibre used and the resulting yarn structure required. The worsted system, for example, is used for processing longer and finer varieties of wool fibre to produce yarns with a smooth, sleek and compact appearance which gives a soft and smooth appearance to fabrics. Worsted yarns are often plied which gives them a greater evenness and makes them easier to weave.

Open-end/rotor spinning has its advantages with regard to production rate, use of floor space, and labour (Lawrence 2003, Goswami *et al.* 2004). However, it is not suitable for worsted processing. Open-end/rotor-spun yarn has less parallel fibre arrangement in the yarn structure and completely irregular twist in terms of twist per unit length and twist angle as well as twist direction due to the distinctive wrapper fibres around the yarn core as shown in Fig. 14.1 (Lawrence 2003, Klein 1987). The production of suitable spun yarn for the worsted industry requires the fibres to be parallel with uniform twist angles and unidirectional twist direction to give fabric a soft and warm texture.

Fibre orientation in friction spinning is also poor (Fig. 14.2). After being fed to the high-speed opening roller, the fibres become individualised. During separation, transportation and landing they lose their orientation, and crumple as they are deposited in the yarn structure. Fibre orientation in friction spun yarn is therefore inferior when compared to open-end/rotor spun yarn (Goswami *et al.* 2004, Lawrence 2003, Manich *et al.* 1987).

Air-jet spinning technology produces a distinctive type of yarn called fasciated or wrapped yarn. The idealised structure of fasciated yarn consists

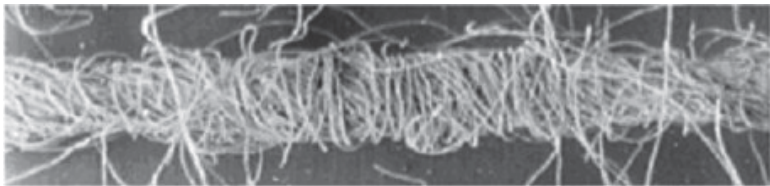

14.1 OE rotor spun yarn.

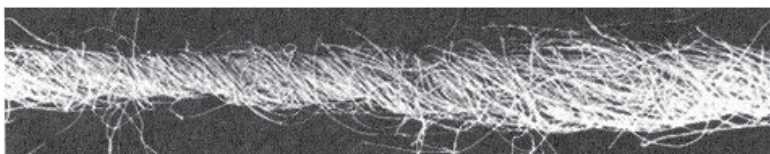

14.2 OE friction spun yarn.

of parallel fibres in the core, which are held together by wrapper fibres (Oxenham 2001) as can be seen in Fig. 14.3. One of the most important developments in air-jet spinning is vortex spinning, which is 20 times faster than ring spinning (Goswami *et al.* 2004). As can be seen from Fig. 14.4, the appearance of vortex spun yarn is closer to that of ring spun yarn rather than air-jet spun yarn (Basal and Oxenham 2003). However, in both cases the quality of spun yarn is still not suitable for worsted spinning or any long staple fibre.

Hollow spindle spinning is another way to produce a continuous assembly of long staple fibres at a much higher spinning speed than from the ring spinning system by separating twisting and winding. As can be seen from Fig. 14.5, in comparison with ring spun yarn, wrap spun yarns are less hairy, more compact and fairly stiff (Klein 1993). A similar quality of yarn is achieved through the Siro spinning process of spinning single yarn from two rovings simultaneously under the same drafting system (Shaikhzadeh Najar *et al.* 2006). This method of twisting two strands produces yarns which are more compact and less hairy in comparison with conventional twisting methods. Siro-spun yarn structure more closely resembles that of worsted yarn (*Textile Horizons* 1982).

In most cases, as has been seen, these spinning techniques are not suitable for processing wool fibres for the worsted industry. The yarn structures from

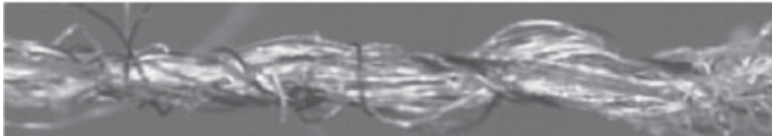

14.3 Air-jet spun yarn.

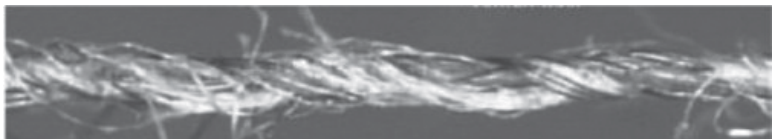

14.4 Vortex spun yarn.



14.5 Wrap spun yarn.

these techniques do not meet the accepted requirement for worsted yarn, i.e. the yarns generally do not have the necessary smooth surface and soft hand. The fibres in manufactured yarn for the worsted industry are well arranged, i.e. fibres are parallel in the body of the yarn, twist angle is uniform, and direction of twist is either 'S' or 'Z'. These problems of yarn structure have led to the development of self-twist spinning.

## 14.2 Self-twist spinning: principles

Self-twist or false-twist spinning uses two rovings. Each one is passed through a pair of rollers that are both rotating and oscillating. Each set of rollers twists its roving in a direction opposite to the other. The uneven motion of the rollers forms strands that have both twisted and untwisted areas. Adjacent ends of the two strands are allowed to untwist around each other to produce a ply yarn.

Self-twist yarn is the result of the spontaneous release of energy which is stored in the single strand by the action of twist insertion (Elkhamy 2007). The torque of the freshly emerging strands from the front rollers of the drafting system causes them to try to untwist. Hairs from one strand are caught by the other. The individual strands twist about their own axes and consolidate the grasp of the hairs from the other strand. Meanwhile the paired strands twist about their common axis to relieve the torque in the individual strands. There is a zero twist zone at each changeover and this zone increases as the strands wrap around each other in separate twisted zones. The transfer of torque from the component strands is reduced as the local ply twist increases and the system comes into equilibrium. There is a resulting series of slightly extended zero-twist zones interleaved with ply-twisted sections of yarn (Lord 2003). Care must be taken to space the untwisted areas of each yarn in such a way that a loosely twisted section of one yarn never coincides with a loosely twisted section of the other yarn, or a weak spot would result.

Fibre length must be at least several times greater than the no-twist zones in order to provide sufficient friction force in a half-cycle before the fibre is subjected to the opposite twist. Self-twist spinning has therefore become established as a system for producing ply yarns from medium to long staple fibres, especially wool and some synthetic fibres such as high-bulk acrylics for knitting as well as wool-acrylic blends (Simpson and Crawshaw 2002). The system overcomes the limitations associated with package rotation that apply to ring spinning. Twisting and winding are separated, with the result that large packages of unbroken yarn can be made. Yarn cheeses can contain up to 9 lb of yarn (Lord 2003). The shuffling/twisting rollers are capable of inserting twist at extremely high rates. Its advantages therefore include a higher production rate (over 10 times that of conventional ring

spinning) and higher spinning limits (35 fibres per strand). The technology requires less space, uses less power and produces less waste (Simpson and Crawshaw 2002). Yarn can therefore be produced at both high speeds and low cost relative to ring spinning. Its disadvantages include weaker yarns, caused by the presence of zero-twist zones, and inconsistencies in the yarn which can produce streaks in the final fabric (Lord 2003).

### 14.3 Self-twist spinning technology

A typical self-twist spinning machine contains a number of production channels. Each channel comprises:

- A roving supply package delivering the two rovings to the rollers
- A roller drafting section with an oscillating (shuffling) and rotating (twisting) rollers
- A strand combination system which ensures the strands are combined to avoid zero-twist zones coinciding
- A take-up system.

The first self-twist spinning system was devised at the CSIRO laboratories at Geelong, Australia, by Henshaw (1971). To date, the only method of alternate (S and Z) twist insertion into a staple fibre is the Repco self-twist machine (GB Patent 1962, US Patent 1977a) and the WinSpin machine from the Saurer Group. In the Repco system, introduced in the 1970s, the top and bottom twisting rollers are typically 22.9 cm long and 4.1 cm in diameter. Both are hollow cylinders mounted horizontally and coated with rubber. The drafted fibre strands pass through the rollers which reciprocate axially in opposition to insert intermittent 'S' and 'Z' twist. The rollers also rotate to advance the finished strands of fibre. The twisting rollers are mounted on two externally pressurised air bearings, which obtain their motion by means of a pair of rods connected to a pair of epicyclic gearboxes, operating at 180° out of phase. The epicyclic drive unit conveys the reciprocating as well as the rotating motion of the self-twist rollers. The twisting rollers reciprocate at a fixed stroke of 7.6 cm, and rotational delivery speed is synchronised with the front drafting rollers' delivery speed. The epicyclic driving unit can reciprocate 7.6 cm, up to 1000 oscillations per minute, and gives a nominal cycle length of 22 cm. In contrast to the bottom twisting roller, the upper twisting roller is mounted so that it can pivot freely in order to regulate the nip pressure using a deadweight system. The level of twist in the fibre strands is controlled by the pressure exerted on the bottom roller by the top roller. The level of twist is adjusted by changing the weight. Phasing is introduced to the self-twist yarn by increasing the pass length of one of the strands prior to the convergence point in order to prevent two adjacent no-twist zones at twist changeover coinciding with each other. A diagram of the Repco self-twist machine is shown in Fig. 14.6.

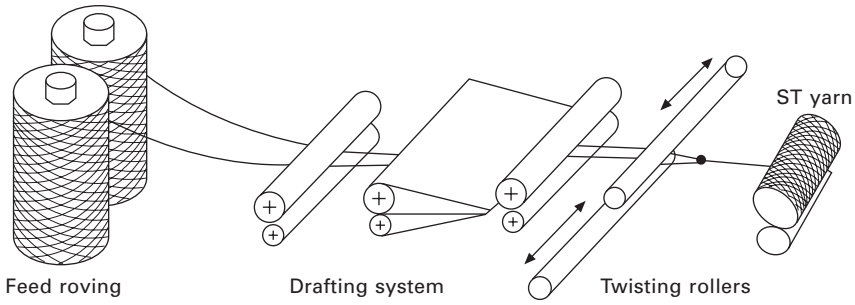

14.6 Principle of self-twist machine.

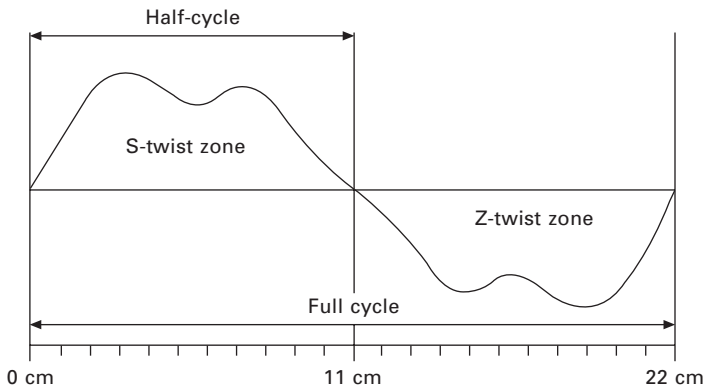

14.7 Typical twist distribution in self-twist yarn.

The standard Repco system consists of a creel for four pairs of rovings or strands, i.e. two rovings per self-twist yarn. S and Z twist is inserted alternately into each of the pair of strands. These are then brought together out of phase by the strand combination system so that they wrap around each other to form an alternating twist two-ply structure (22 cm total cycle length). The drafting zone is a modified double-apron system with three sets of rollers (back rollers, aprons and front rollers), the optimum draft being around 25 for wool (Simpson and Crawshaw 2002). Figure 14.7 shows twist distribution of a full cycle length plus no twist zones.

When two strands converge with coincidental zero-twist and twist regions, the resultant yarn is called in-phase self-twist yarn. Figure 14.7 shows an in-phase or zero-phase ST yarn profile. If, using the strand combination system, one of the strands travels a longer path before coming together with the second strand, so that the zero-twist zones are displaced, the resultant self-twist yarn is called a phased self-twist yarn. Phasing can be defined as the ratio of the path length difference to the cycle length, as shown in

equation 14.1 expressed as a fraction of  $360^\circ$  which corresponds to a full cycle length:

$$\text{Phasing degree} = \frac{\text{path length difference in cm}}{\text{full cycle length in cm}} \times 360^\circ \quad 14.1$$

A modified Repco spinning machine was introduced at ITMA 2003 as the Macart spinning system S300 ST. The S300 ST spinning machine is equipped with a pre-drafting system in order to process sliver of up to  $12 \text{ g m}^{-1}$  rather than roving, and on-line steaming technology after self-twisting to relax the yarn and allow for bulkier yarn packages (Oxenham 2003). The S300 ST spinning machine also incorporates an intermediate traction roller to control tension between the twisting section and the yarn coiling head prior to the bulking chamber.

The WinSpin self-twisting spinning machine from Oerlikon Saurer also uses two rollers which simultaneously oscillate and rotate to insert twist. In the WinSpin machine the direction of twist changes every 11 cm, producing a no-twist zone every 11 cm. As can be seen from Fig. 14.8(a), after the twisted strands leave the twisting roller, one strand in each pair passes over an idler (Fig. 14.8(b)) in order to make a longer pass prior to joining together to make an out-of-phase self-twist yarn. The two sets of yarn are then combined and wound on the package to make four-ply knitting yarn. The production speed can reach up to  $250 \text{ m min}^{-1}$ .

### 14.3.1 Self-twist spinning using air-jet technology

The distance between no-twist zones is the result of the time taken for the self-twist rollers to change their direction in proportion to the production speed. The existing technology available with the ST rollers in the Repco spinning machine means that, with the minimum time required for the roller

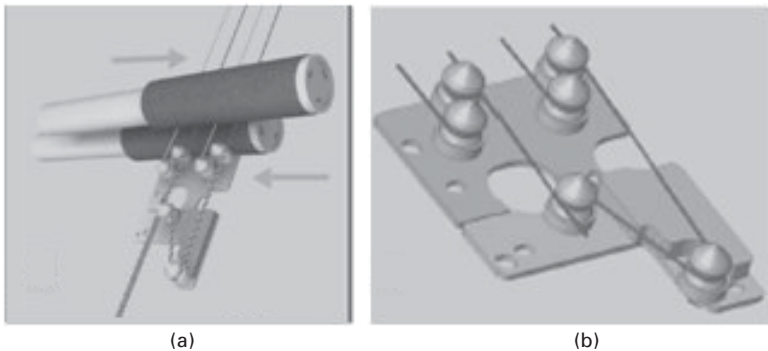

14.8 Principle of WinSpin self-twist machine (courtesy of Saurer).

to reverse after stopping, there is a minimum distance between no-twist zones of around 20 mm. Air-jet technology provides switching more rapidly in the direction of twist from 'S' to 'Z' or vice versa than is possible with a self-twist roller system. US patents of (1991, 1993a, 1995, 1996a, 1996b, 1997 and 1998) and GB patent 1341918 describe an alternative method of twist insertion which uses torque and booster jets. After the twist is imparted into each individual strand by the torque and booster jets, the twisted strands are allowed to self-twist and bond together. The method produces a cycle length (S and Z) of up to 140 inches. Other US patents (1977b, 1993b) also describe the application of air-jet technology for production of self-twist yarn. Most of the devices are designed for insertion of alternate twist into filament yarns. A method of using tandem air jets was introduced by Mahmoudi *et al.* (2003). Their method used four jets, two for each twist direction as shown in Fig. 14.9.

Comparing the results of two self-twist yarns produced using ST roller and air-jet technology showed that the ST roller's yarn appearance was less hairy compared to the air-jet ST yarn, especially at high pressure (Henshaw 1971). The rate of twist loss with production speed was less with ST rollers than with air-jet technology. In air-jet spinning the rate of twist insertion is not known directly because the twist is inserted by means of energy created by the vortex at the twister nozzle. If one assumes that the fibres in the twisting channel at the twist nozzle are situated in the middle of the twisting chamber and the vortex is uniform and tangential, then one rotation of the vortex gives one turn of twist. In air-jet spinning, each channel generates a fixed amount of energy per unit of time at a given pressure. If yarn is fed through the channel more quickly, the energy per unit time is divided along a greater length of yarn. Thus the number of turns of twist inserted per unit

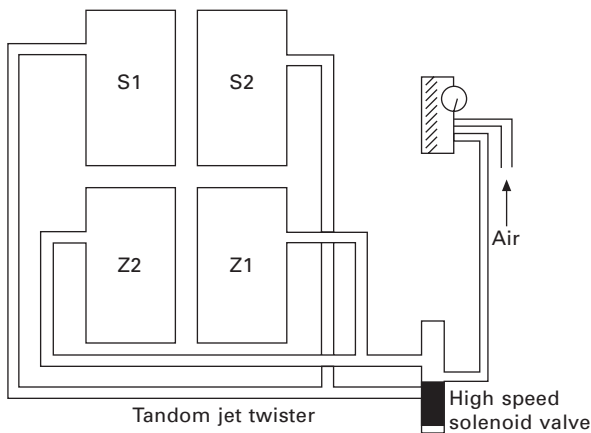

14.9 Tandem air-jet self-twist device.

length of yarn decreases. Although the twist drop was greater for the air-jet self-twist yarn than the ST roller yarn as the production speed increased from 120 to 220 m min<sup>-1</sup>, the no-twist zones were much shorter for the air-jet ST yarn. This could be explained by the speed of changing from one set of jets to another.

The NV air system from Gilbos produces self-twist yarn by using de-torque jets to insert the alternating twist with no twisting zones reinforced by the use of intermingling jets (Elkhamy 2007). Figures 14.10 and 14.11 show this system. The NV air twister self-plying machine produces yarn at a rate between 400 to 800 m min<sup>-1</sup>, with 50 to 250 tpm with a twisted length of 25 to 150 cm. The air twister applies alternating twist onto filaments to resemble a multi-fold twisted yarn for the carpet industry. It also produces high tenacity yarn for hoses, ropes, and other industrial applications. All machine parameters are fully computer controlled, and each zone can operate independently. The NV air twister machine contains four spindle sections with a total of 12 spindles, i.e. three spindles per section.

Belmont textile machinery (US Patent 2002) uses a maximum of four filament yarns. These travel through yarn separators to rotary air jet twisters in order to prevent the yarns twisting together while they are receiving

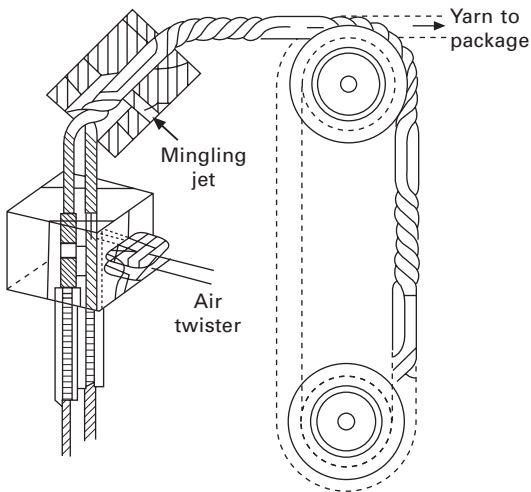

14.10 NV-Gilbos self-twisting device (courtesy of NV-Gilbos).

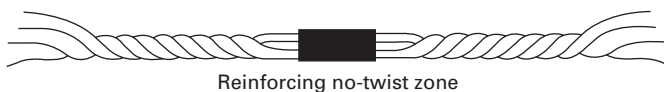

14.11 NV-Gilbos self-twist yarn.

twist. The twisted single filaments yarns are bonded in a group by air tack before they are allowed to ply together to make self-twist yarn. Air tack is inserted using a moving air bonder that allows the Roto-twist machine to be a continuous process that can run at a very high speed of  $550 \text{ m min}^{-1}$ . The twisting elements of the Roto-twist or Fluid-jet twist insertion are shown in Fig. 14.12. The system produces a long twisted zone of about 90 cm with yarn mainly used in the carpet industry.

### 14.3.2 Other variations in self-twist spinning technology

Air vortex technology is a highly promising method of intermittent twist insertion for filament yarn (Australian Patent 1957). The alternating twist is achieved by means of an air vortex from which the yarn is fed to a long convergence tube in which filaments self-twist (Fig. 14.13). Henshaw (1971) noted that a major problem with this system is air escaping from the end of the jet at high speed causing the strand to blow apart at zero-twist regions. Commercial machines using this technology were exhibited at ITMA 2004.

The centrifugal-jaw twister is a well-established false-twisting device generally associated with ring spinning machines for wool. The centrifugal-jaw twister comprises a stationary tube through which the strand passes through the rotating central tube. On rotation centrifugal force causes the jaws to grip. The twisting tube is capable of limited axial movement and is connected to an arm, as shown in Fig. 14.14, which in turn carries a cam follower. When it has reached the lobed part of the arm, the twisting tube is forced forward. This also forces the jaws to open and thereby interrupts the twisting action. The alternative twist is achieved by intermittent reversing of the twisting

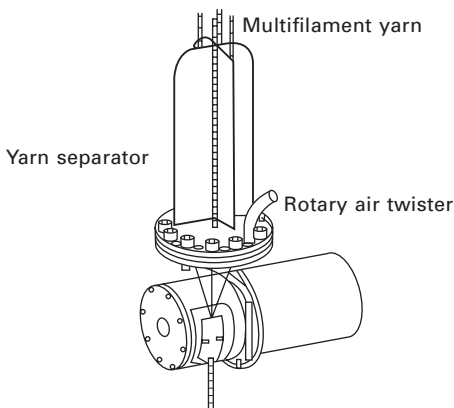

14.12 Belmont Roto-twist twist elements (courtesy of Belmont textile machinery).

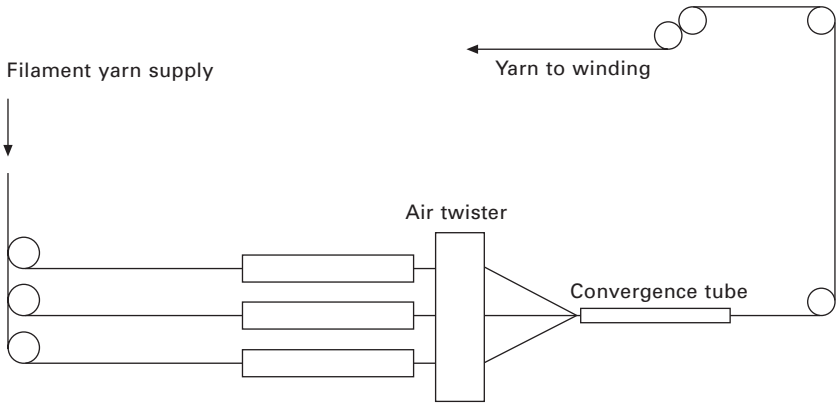

14.13 Self-twist spinning machine for continuous filaments (courtesy of CSIRO).

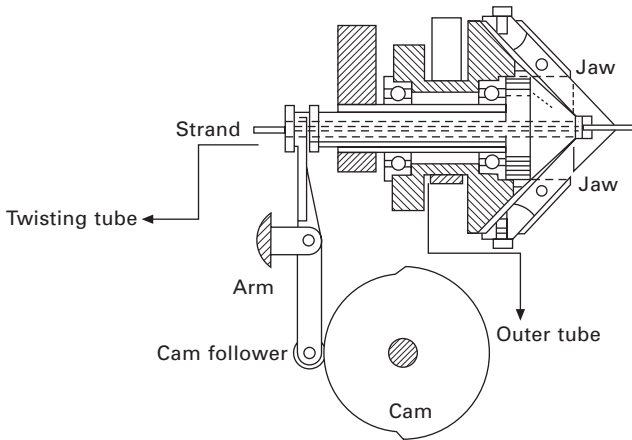

14.14 Centrifugal-jaw twister (courtesy of CSIRO).

tube. The number of twists is dependent mainly on two parameters: the extent of centrifugal-jaw strength and the speed of passing fibre strand through the twisting tube. The cam speed controls the yarn cycle length. The degree of phasing is also determined by the rotational disposition of the cam.

The tube twister is a method of intermittent twist insertion reported by Rohatgi (1974). This method of alternating twist insertion basically consists of a pair of tubes which are oscillated between two moving belts (Fig. 14.15). As the tubes touch the top belt they insert 'Z' twist, while contact with the bottom belt produces 'S' twist. Ozmen (1976) noted that, due to low twisting efficiency and slippage, the tube twisting method could only be used for producing woollen self-twist yarn.

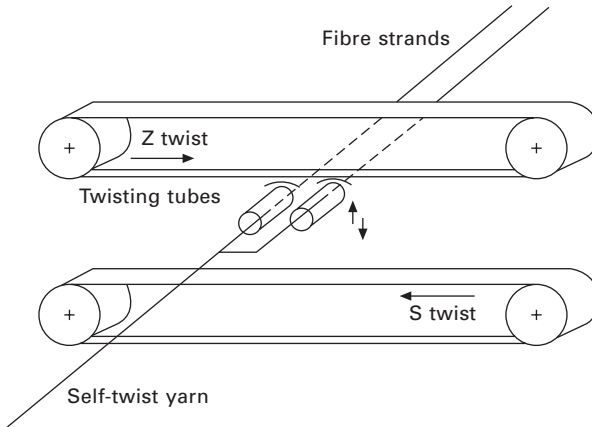

14.15 Tube twister (courtesy of J. S. Rohatgi).

#### 14.4 Factors affecting strand twist

The degree of twist in self-twist yarn is dependent upon the value of twist in the strand. If there is any variation of initial twist in the strand, in due course that variation will be translated into the yarn (Henshaw 1971, Hassanin 1982). There are a number of factors which affect the level of twist in self-twist yarn. These factors include:

- Spinning speed
- Friction
- Tension
- Phasing
- Fibre diameter
- Strand thickness
- Load.

Using a high speed flash and still camera, Mahmoudi (1986) showed that, as the production speed increases from 120 to 220 m min<sup>-1</sup>, the strand twist is reduced. The effect of production speed on the strand twist reduction can be seen from Fig. 14.16. Mahmoudi suggested that the decrease of strand twist efficiency at higher production speed is due to the reduction of contact between the strands and twisting roller nip as the result of increasing distance between the two twisting rollers at the nip point. Figures 14.17 and 14.18 show the effect of production speeds on the loss of self-twist as a result of increasing distance between the two twisting rollers at the nip. Mahmoudi (1986) also reported that if the production speed of self-twisting rollers increases while the package builds up, winding-up tension start to reduce, further reducing twist. Variation of twist due to tension fluctuation will have an effect on the resultant yarn physical properties (Hassanin 1982).

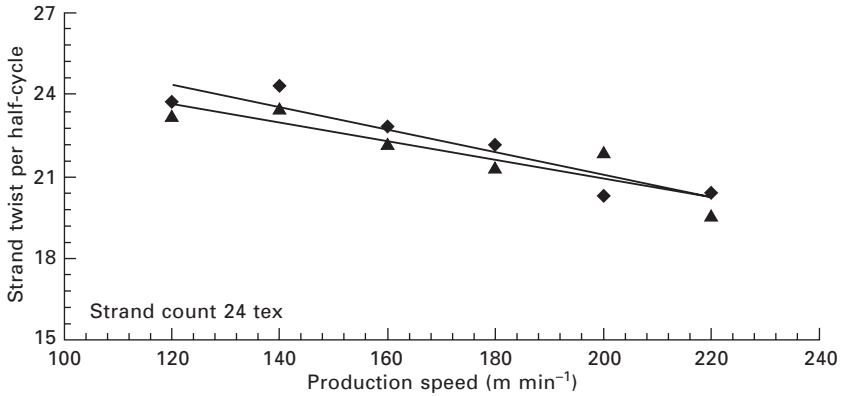

14.16 Effect of production speed on strand twist.

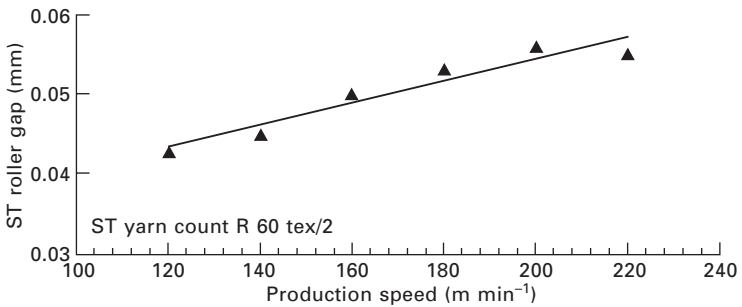

14.17 Effect of ST roller speed on the nip gap.

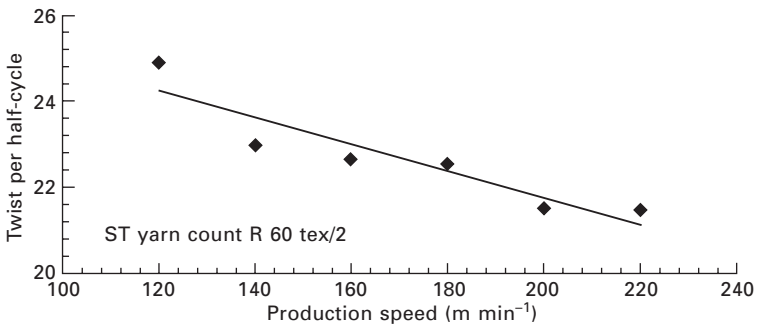

14.18 Effect of nip gap on yarn twist per half-cycle.

As spinning production increases, there is a further loss of twist due to the frictional resistance in the guide. The reduction of strand twist due to friction before and after the guide point is shown in Fig. 14.19. Increasing winding tension also hinders the formation of twist (Ozmen 1976, Ozturk

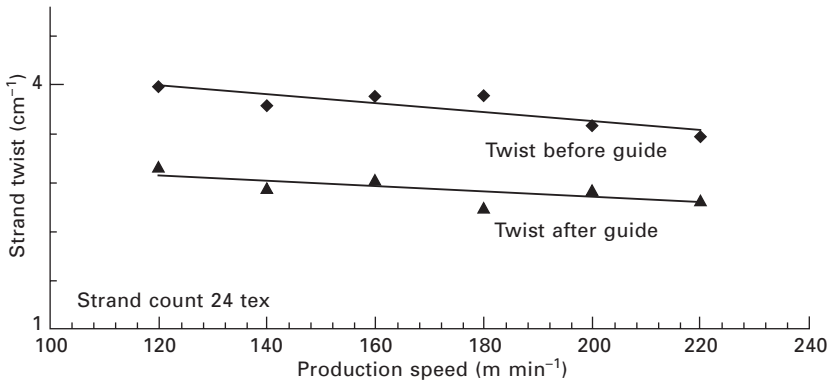

14.19 Twist before and after convergence guide.

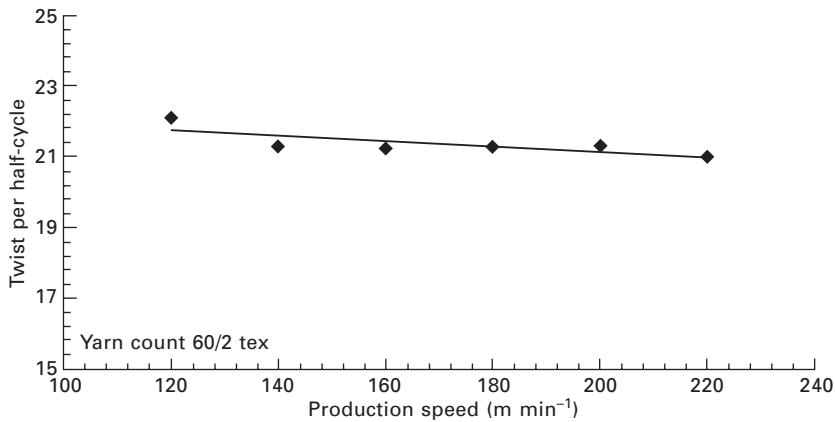

14.20 Effect of adjusting winding tension on self-twisting.

1976, Hassanin 1982). Adjusting tension at the same time as production speed minimises the reduction of twist (see Fig. 14.20). Figures 14.21, 14.22 and 14.23 show the effects of tension variation combined with increasing roller production speed on twist. Fibre density is also significant. Repco recommends that the winding tension should be a third of self-twist yarn linear density, i.e.  $\text{tension} = \text{linear density (tex)} \times 1/3$ . This provides maximum ply twist and a good quality package for subsequent processing. Increasing the amount of phasing or displacement of one of the two strands at the convergence point reduces self-twist formation due to the loss of twist as one of the strands travels a longer distance (Inceoglu 1979, Ragab 1977, Mahmoudi 1986).

Ragab (1977) reported results on three different acrylic fibre diameters, namely 3, 5, and 9 denier fibres, with each fibre diameter spun into five different yarn counts. From Table 14.1 it can be seen that as the diameter

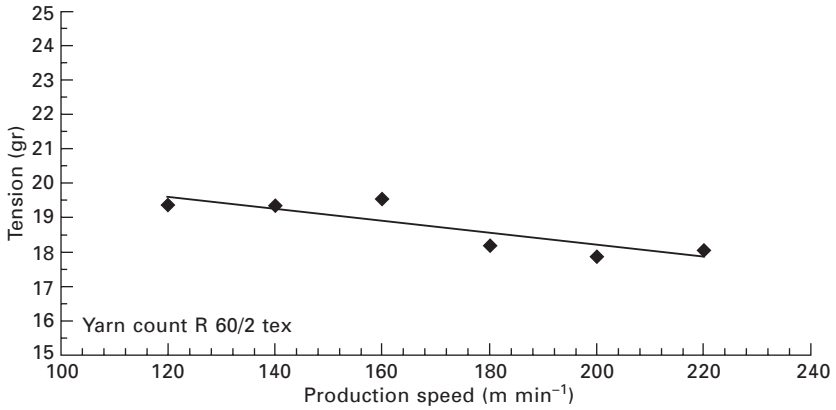

14.21 Effect of production speed on winding-on tension.

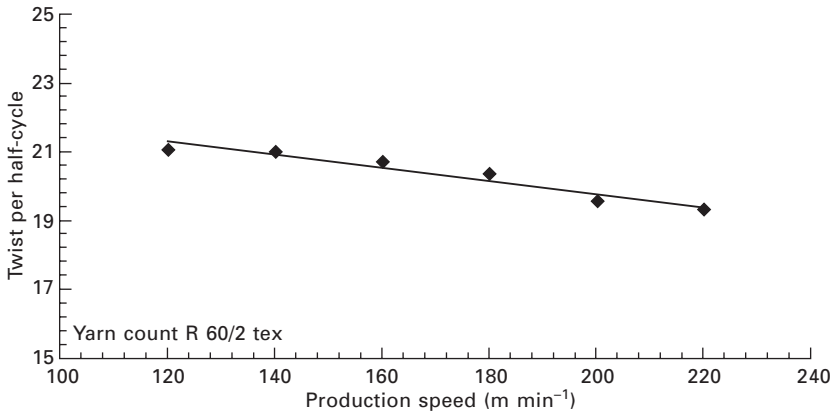

14.22 Effect of tension variation on twist per half-cycle.

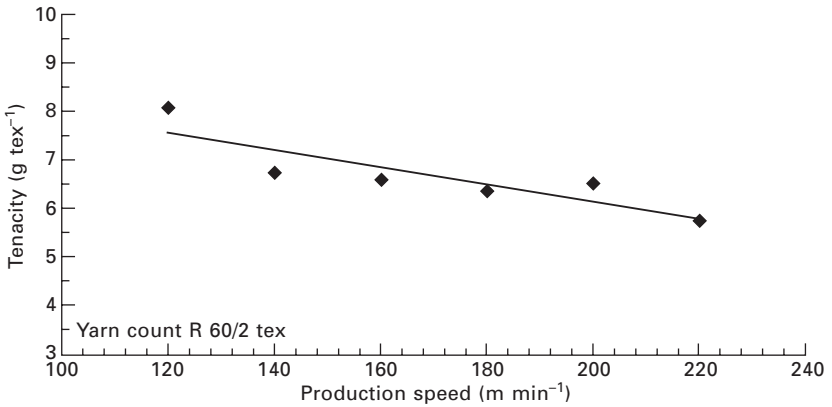

14.23 Effect of tension variation on yarn tenacity.

Table 14.1 Effect of fibre denier on ST twist yarn

3 denier		5 denier		9 denier	
ST yarn tex	Twist per half-cycle	ST yarn tex	Twist per half-cycle	ST yarn tex	Twist per half-cycle
95.6	15.0	94.8	16.7	94.5	17.0
86.4	17.2	85.8	18.1	86.0	18.5
79.0	17.9	77.6	19.6	78.0	20.1
70.6	20.2	70.3	21.3	70.0	22.0
60.0	22.6	60.8	23.5	59.5	24.1

Source: courtesy of Ragab (1977).

Table 14.2 Effect of wool fibre denier on ST twist yarn

20.9 mm (64's)		29.7 mm (50's)		36.9 mm (40's)	
ST yarn tex	Twist per half-cycle	ST yarn tex	Twist per half-cycle	ST yarn tex	Twist per half-cycle
36.0	30.9	–	–	–	–
51.9	26.8	–	–	–	–
72.4	23.6	71.1	21.2	71.3	18.5
82.4	21.4	81.3	18.7	81.3	17.0
107.3	17.5	104.4	17.0	105.0	15.0
–	–	122.6	14.8	122.5	13.4
–	–	140.5	13.1	140.0	11.8

Source: courtesy of Ragab (1977).

of the fibre increased, so did the level of twist in the self-twist yarn. This may be because fibre diameter has an effect on the twisting efficiency of the self-twist roller (Hassanin 1982). Ragab (1977) also repeated the experiment using three different diameters of wool fibre, namely 20.9, 29.7, and 36.9 mm (64s, 50s, and 40s). He also cited Carnaby (1973) who reported results using New Zealand half-bred and cross-bred wools processed on the Repco self-twist machine. He found that, to achieve a high level of twist, the roller load needs to increase as wool fibre diameter increases (see Table 14.2). On the other hand, strand twist is inversely proportional to strand thickness (Inceoglu 1979, Ragab 1977, Ozturk 1976, Lappage 1978, Mahmoudi 1986).

In order to reduce fibre slippage while receiving twist at the nip point of oscillating twisting rollers, some load is added to the top twisting rollers. The amount of load depends on the yarn count. Inceoglu (1979) showed that, by increasing the roller loading in step with increasing in production speeds, it is possible to maintain self-twist yarn quality. Increasing the top twisting roller load, while increasing the spinning speed, helps to keep friction between the twisting rollers at the nip point constant. Figure 14.24

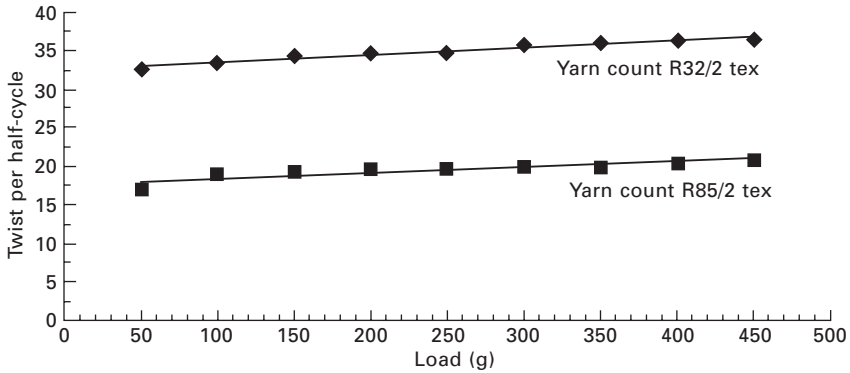

14.24 Effect of increasing top twisting roller load on twist per half-cycle.

shows the effect of top twisting roller loading on twist per half-cycle of two different yarns. An initial increase in the twisting roller loading results in an increase in the amount of twist per half-cycle, but beyond a certain maximum, a further increase in the loading causes no significant change in the twist level (Henshaw 1971, Inceoglu 1976, Hassanin 1982, Ragab 1977). This is because, as loading increases, the nip pressure flattens the strands, making twist insertion more difficult. The critical twisting roller loading point, the maximum load required to produce maximum twist, varies considerably according to fibre (Henshaw 1971, Ozmen 1976).

## 14.5 Self-twist yarn strength and stability

The zero-twist zone is one of the most important characteristics of ST yarn. Zero-twist zones occur at every change of twist direction, i.e. from S to Z or vice versa. The level of twist in the half-cycle zone directly affects the zero-twist length. Zero-twist length also increases with the increase in the spinning speed. Henshaw (1971) argued that this is due to the strand separation during the self-twisting action at the convergence point. As the spinning speed increases, the loss of twist as a result of the stronger centrifugal force causes the strands to separate.

Due to the zero-twist zones at every twist changeover, ST yarns contain points of weakness along the length. In the case of an in-phase yarn (see Fig. 14.25(a)), if the length of zero-twist zones is equal to or greater than the length of bridging fibres, then the force required to break the yarn is low. This confirms the importance of fibre length in self-twist spinning since it is essential that the fibres should bridge the zero-twist zones. The strength of the no-twist zone varies with staple length. It is necessary to use a staple length of several inches to get adequate strength. A number of techniques are

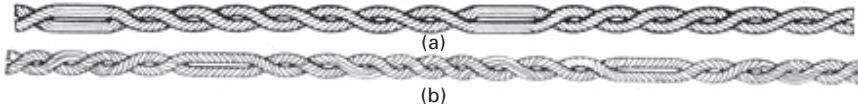

14.25 Self-twist yarn: (a) in-phase; (b) phased yarn.

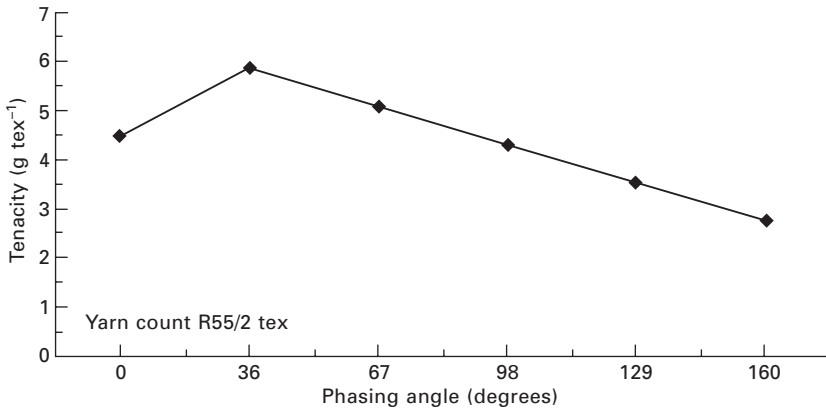

14.26 Effect of phasing angle on self-twist yarn tenacity.

used to stabilise weak zones. These include intermittent air vortices created by switched nozzles to false-twist the individual strands before assembly at the weak points. This technique is limited to speeds of  $100 \text{ m min}^{-1}$ . Another technique is to size the yarns with water-soluble adhesive before further processing. Air-jet texturing can create lateral fibre migration which can help lock the yarn structure (Lord 2003).

Phasing also affects zero-twist length (Henshaw 1971, Inceoglu 1979, Ragab 1977, Ozturk 1976, Mahmoudi 1986). Increasing the path length of one of the strands will prevent two no-twist zones coinciding with each other (see Fig. 14.25(b)), which means that each no-twist zone will be reinforced by the twisted section of the neighbouring strand, therefore improving self-twisted yarn strength. However, increasing the strength of self-twist yarn by phasing is limited. Beyond an optimum strand path length or phase angle, the yarn strength is reduced as a result of loss of twist that is associated with the longer path length. As can be seen from Figs 14.26 and 14.27, the tenacity of self-twisted yarn increases as the phase angle moves from zero to  $36^\circ$ . However, the degree of twist per half-cycle also reduces as the phase angle changes, ultimately reducing tenacity as a result of twist loss.

Generally self-twist yarn is a balanced structure. If the two alternating twisted strands are brought in contact side-by-side and are allowed to rotate, then each tends to untwist. The friction between two strands causes each strand to twist about the other and the twisting continues until the untwisting torque of the strand is balanced by the opposing torque generated in the plied

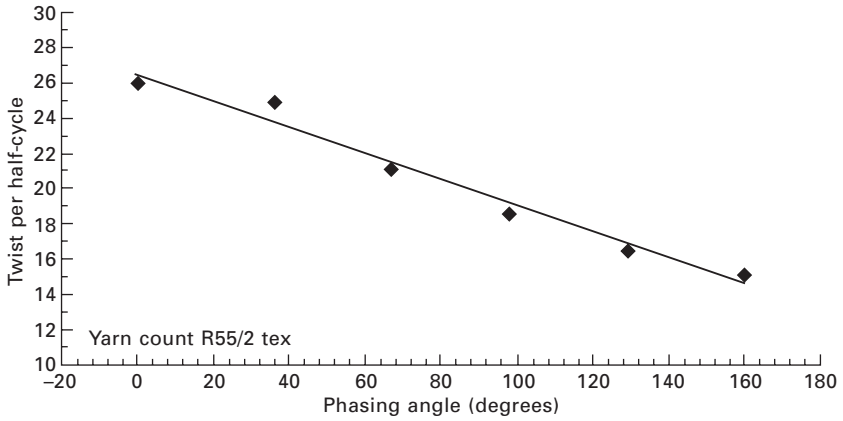

14.27 Effect of phasing angle on twist per half cycle.

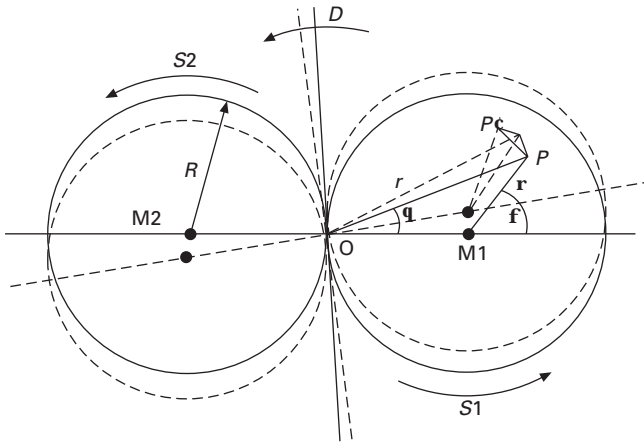

14.28 Self-twist yarn cross-sectional model (Henshaw, 1970).

structure. Hassanin (1982) described the relationship between the strand and plying torque for a staple yarn as follows:

$$\text{Untwisting torque} \leq \text{binding torque} + A \tag{14.2}$$

where  $A$  represents the meshing or interlocking of the two strands. The twist balance has been analysed by Henshaw (1970) who assumed that self-twist yarn consists of two circular strands each of radius  $R$  as shown in Fig. 14.28 having twists  $S_1$  and  $S_2$ . The initial strand twists  $S_1$  and  $S_2$  and their self-twist  $D$  are defined as

$$D = \frac{dq}{dz}, S_1 = \frac{df_1}{dz}, S_2 = \frac{df_2}{dz} \tag{14.3}$$

By considering the yarn co-ordinates  $r$ ,  $\theta$ ,  $z$  and co-ordinates about each strand axis  $P$ ,  $\phi$ , the relationship between the ply-twist and initial strand twist was found to be  $6D = -(S_1 + S_2)$ . The negative sign indicates that the twist in the ply-twist is in the opposite direction to that of the strand twist.

When a self-twist yarn is subjected to tension  $T$ , the untwisting force  $F$  will tend to unravel the yarn structure:

$$F = \frac{TR}{2} \cdot \frac{dD}{dz} \quad 14.4$$

To counterbalance this there is a compressional force which is created at the same time as the untwisting force as a result of the two strands acting on each other. This tends to bind and stabilise the structure. The compressional or binding force,  $N$ , can be represented by:

$$N = \frac{TR}{2} \cdot D^2 \quad 14.5$$

To ensure the stability of in-phase yarn the conditions given in the following equation should be satisfied:

$$F \leq \mathbf{m}N + A \quad 14.6$$

For the phased yarn, the conditions would be as follows:

$$\left| \frac{dS_1}{dz} - \frac{dS_2}{dz} \right| \leq B \quad 14.7$$

where  $\mathbf{m}$  is the coefficient of friction,  $A$  is the friction between strands, or meshing or interlocking of the surface features of two strands, such as fibre loop and ends, and  $B$  is the resistance to the mutual rolling of the two strands, which again depends on projecting fibre loop and ends.

Ozmen (1976) combined equations 14.4 and 14.5 in equation 14.6 to arrive at the following:

$$\frac{TR}{2} \cdot \frac{dD}{dz} \leq \frac{TR}{2} D^2 + A \quad 14.8$$

From this equation it can be seen that the interlocking of surface fibres  $A$  is required, otherwise  $F$  is always greater than  $N$  at any point where  $D$  is zero, resulting in the self-twist yarn being unstable. Henshaw's model ( $6D = -(S_1 + S_2)$ ) predicted that the ply twist is equal to one-sixth of the sum of the initial strand twists. Rohatgi (1974) concluded that the ply twist is approximately equal to 28.7% of the sum of the initial strand twists for wool fibres. Henshaw (1971) stated that with a strong phased self-twist yarn, breaks could take place at any random point on the yarn. However, it was reported by Ragab (1977) that Henshaw's statement is only true for strongly phased

yarns, and he stated that generally the conventional phased self-twist yarn tends to break about the zero-twist zones.

Generally, spun yarns for weaving require two-fold unidirectional twist (S or Z). This requires adding twist to the self-twist yarn (see Figs 14.29(a) and (b)). The amount of added twist must be high enough to avoid pairing. Pairing twist is the amount of twist added to the self-twist yarn which is necessary to make all self-twist unidirectional or zero-twist. It is called pairing twist, 'PT', and results in the two single strands in one zone lying parallel or paired, as shown in Fig. 14.29(c). The relationship between strand twist and self-twist is found in practice to range from 1.4 to 1.5 and it has been found by Ellis and Walls (1973) that for most practical purposes pairing twist = 1.55  $\sphericalangle$  self-twist. The added twist can be defined as the total twist added to the self-twist yarn in order to produce unidirectional two-fold yarn as shown in Fig. 14.29(d). Therefore, added twist consists of two components: (a) pairing twist which is dependent only on strand twist, and (b) a twist angle component which is dependent only on yarn count. Equation 14.9 for added twist was suggested by Ellis and Walls (1973):

$$\text{Minimum added twist per metre} = \frac{T}{0.071} + \frac{880}{\sqrt{\text{tex}}} \quad 14.9$$

where  $T$  is self-twist per half-cycle, and 0.071 is the result of  $0.11 \div 1.55$  (0.11 m is the length of a half-cycle).

The particular structure of self-twist yarn has implications for later processes such as knitting. Ragab (1977) has shown that a combination of structure and a high level of self-twist causes knitted fabric to have a distorted appearance when the ST yarn was knitted into a single jersey structure as shown in Fig. 14.30(a). He explained that the distortion and cockling of single jersey knitted fabric is due to the tendency of the self-twist yarn to recover its equilibrium twist distribution. This will occur in the fabric after the yarn has been subjected to tension during knitting. However, if the same yarn is knitted into a 1  $\sphericalangle$  1 rib structure, it has an acceptable appearance as can be seen in Fig. 14.30(b). In a balanced structure like 1  $\sphericalangle$  1 rib, stitch distortion will not occur because yarn residual torque will be equally distributed across

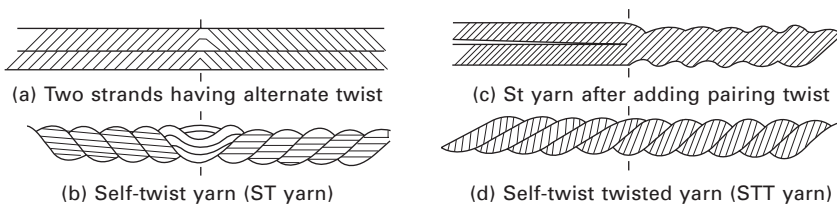

14.29 Self-twist twisted (STT) yarn or two-fold unidirectional twisted yarn.

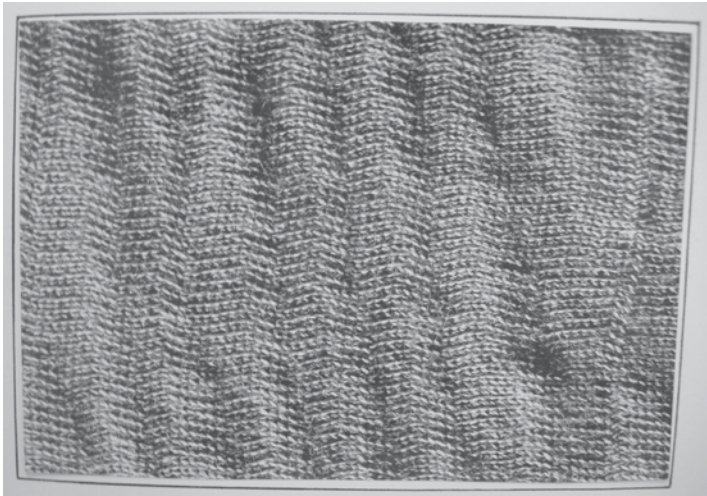

(a)

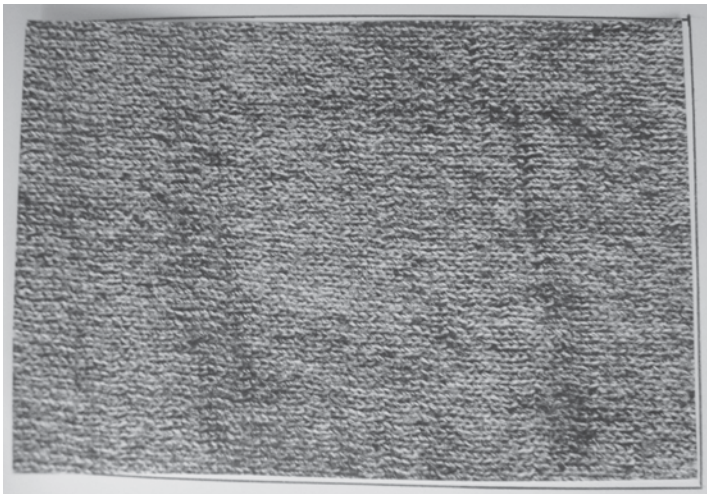

(b)

**14.30** Effect of ST yarn twist level and knit structure on fabric appearance.

the fabric structure. Henshaw (1976) also found that a high level of self-twist causes stitch distortion. Steam treatment to relax self-twist yarn produces an improved knitted fabric appearance in either structure, single jersey or 1  $\nabla$  1 rib fabric, as can be seen in Figs 14.31(a) and (b) for single jersey and 1  $\nabla$  1 rib respectively.

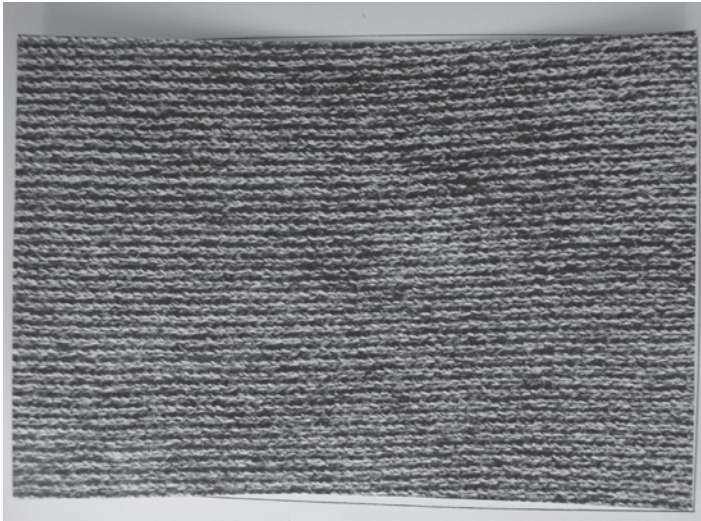

(a)



(b)

14.31 Effect of ST yarn relaxation and knit structure on fabric appearance.

## 14.6 References and sources of further information

Australian Patent 224,281, 1957.

Basal, G. and Oxenham, W. (2003), 'Vortex spun yarn vs. air jet spun yarn', *AUTEX Research Journal*, Vol. 3, No. 3, September, pp. 96–101.

Carnaby, G. (1973), Wool Research Organisation of New Zealand, Comm. No. 19, September.

- Elkhamy, D.S. (2007), Ph.D. Thesis, Drexel University, Philadelphia, PA.
- Ellis, B.C. and Walls, G.E. (1973), *Textile Institute and Industry*, The Textile Institute, Manchester, April.
- GB Patent 1,015,291, 1962.
- GB Patent 1,121,942, 1965.
- GB Patent 1,341,918.
- GB Patent 1,424,005, 1972.
- Gore, C. (1984), in *Tomorrow's Yarns*, symposium, UMIST, Manchester June.
- Goswami, B.C., Anandjiwala, R.D. and Hall, D.M. (2004), *Textile Sizing*, Marcel Dekker, New York.
- Hassanin, H.M.M. (1982), Ph.D. Thesis, University of Leeds.
- Henshaw, D.E. (1970), 'A model for self-twist yarn', *Journal of The Textile Institute*, March, Vol. 61, No. 3.
- Henshaw, D.E. (1976), *Textile Institute and Industry*, The Textile Institute, Manchester, Vol. 14, p. 157.
- Inceoglu, I.C. (1979), M.Phil. Thesis, University of Leeds.
- Klein, W. (1987), *The Technology of Short-staple Spinning Short-staple Spinning, Volume 1*, published by The Textile Institute, Manchester.
- Klein, W. (1993), *The Technology of Short-staple Spinning Short-staple Spinning, Volume 2*, published by The Textile Institute, Manchester.
- Lappage, A. (1978), *Journal of the Textile Institute*, Vol. 69, p. 17.
- Lawrence, C.A. (2003), *Fundamentals of Spinning Technology*, Woodhead Publishing, Cambridge.
- Lord, P.R. (2003), *Handbook of Yarn Production*, Woodhead Publishing, Cambridge.
- Macart Textile Machinery Ltd, Macart House, Farnham Road, Bradford, West Yorkshire, UK.
- Mahmoudi, M.R. (1986), M.Phil. Thesis, University of Leeds.
- Mahmoudi M.R. and Lawrence, C.A. (2003), 'The use of air-jet technology to produce self-twist yarn, Part I: Preliminary study', *Journal of the Textile Institute*, Vol. 94, No. 3/4, p. 149.
- Mahmoudi, M.R. Lawrence, C.A. and Dehghani, A.A. (2003), 'The use of air-jet technology to produce self-twist yarn, Part II: The application of tandem jet twister', *Journal of the Textile Institute*, Vol. 94, No. 3/4, p. 149.
- Manich, A.M. de Castellar, M.D. Barella, A. and Castro, L. (1987), 'The determination of the equivalent machine twist in Dref III friction-spun yarn', *Journal of the Textile Institute*, Vol. 78, No. 2, p. 80.
- Oxenham, W. (2001), *Journal of Textile and Apparel, Technology and Management*, Vol. 1, Issue 2, winter.
- Oxenham, W. (2003), 'Spinning machines at ITMA 2003', *Journal of Textile and Apparel, Technology and Management*, Vol. 3, Issue 3, Fall.
- Ozmen, M. (1976), Ph.D. Thesis, University of Leeds.
- Ozturk, Y.A. (1976), M.Phil. Thesis, University of Leeds.
- Plate, D.E.A. and Lapage, J. (1982), *Journal of the Textile Institute*, Vol. 73, p. 99.
- Ragab, M.A.S. (1977), Ph.D. Thesis, University of Leeds.
- Repco spinning machine instruction manual.
- Rohatgi, J.S. (1974), Ph.D. Thesis University of Leeds.
- Saurer Arbon AG, Textilstrasse 2, CH-9320 Arbon, Switzerland, 2007.
- Shaikhzadeh Najar, S. Khan, Z.A. and Wang, X.G. (2006), 'The new Solo-Siro spun process for worsted yarns', *Journal of the Textile Institute*, Vol. 97, Issue 3, April, pp. 205–210.

- Simpson, W.S. and Crawshaw, G.H. (eds) (2002), *Wool: Science and Technology*, Woodhead Publishing, Cambridge.
- Stalder, H. (1982), in *Annual Conference of The Textile Institute*.
- Stalder, H. (1984), in *Tomorrow's Yarns*, symposium, UMIST, Manchester, June.
- Textile Horizons*, (1982), 'Yarn production', February.
- US Patent 4,055,039, 1977a.
- US Patent 4,058,960, 1977b.
- US Patent 4,246,750, 1981.
- US Patent 4,873,821, 1989.
- US Patent 5,003,763, 1991.
- US Patent 5,179,827, 1993a.
- US Patent 5,228,282, 1993b.
- US Patent 5,465,566, 1995.
- US Patent 5,557,915, 1996a.
- US Patent 5,577,376, 1996b.
- US Patent 5,598,694, 1997.
- US Patent 5,892,241, 1998.
- US Patent 6,345,491, 2002.
- WO Patent 079025, 2008.

## Minimizing fiber damage caused by spinning

---

Y. ELMOGAHZY and R. FARAG,  
Auburn University, USA

**Abstract:** This chapter deals with the subject of fiber damage during spinning. Fiber damage is classified into many forms such as fiber breakage, loss of elasticity, surface deterioration, and fiber neps. Many parameters are introduced in this chapter that represent practical measures of the extent of fiber damage. Issues such as the trade-off between fiber cleaning and fiber damage, and the different modes of fiber damage expected in different yarn-forming or spinning systems, are discussed.

**Key words:** fiber breakage, elasticity, cohesion, cleaning intensity, cleaning efficiency, nep removal efficiency, extent of fiber damage, sliver orientation index, degree of opening, stepwise opening, carding, drafting, ring spinning, spinning triangle, spinning tension, compact spinning, rotor spinning, friction spinning.

### 15.1 Introduction

In general, fiber damage may be defined as a substantial change in one or more of the basic fiber characteristics that can result in a loss of fiber contribution to yarn or fabric performance. Most fiber damage occurring in the spinning process takes place during the preparatory stages of fiber strand and prior to the yarn-forming stage. This is a result of the trade-off that must take place between the need to open the fiber stock and the need to handle the fiber stock extensively. Since opening and cleaning of the fiber stock is primarily achieved using mechanical means (e.g. opening and carding rolls covered with wires and needles), fiber breakage is often an inevitable outcome. Other forms of fiber damage include loss of fiber elasticity, and surface deterioration.

In order to minimize fiber damage, it is important to establish ways to measure the extent of this damage in the context of the overall performance of fibers during processing. In this chapter, many parameters are introduced that can be used in practice to measure and evaluate the degree of fiber damage. Methods to minimize fiber damage are also reviewed in the general sense as details of these methods can be a very lengthy subject. In addition, a brief description of different spinning systems in the context of fiber damage is also presented.

## 15.2 Textile fiber characteristics and processing

For a fiber to be qualified as a textile fiber, three basic characteristics must be satisfied. These are high slenderness or aspect ratio, high flexibility, and optimum surface cohesion.<sup>1</sup> With regard to the first characteristic, a fiber is often defined as a structure of a substantially large length to diameter ratio, that is, aspect ratio ( $l/d$ ). Typical values of aspect ratio for fibers may range from 200 to several thousands. Natural fibers exhibit inherent aspect ratio, while synthetic fibers can be made into any level of aspect ratio. In relation to performance criteria, different aspect ratios can result in different levels of strength and stiffness in yarns and fabrics. From a design viewpoint, fibers of high aspect ratio should result in stronger yarns than those of low aspect ratio by virtue of the long inter-fiber contact and the possibility of placing more fibers in the yarn cross-section (more fiber compactness). For the same material, long and fine fibers are more flexible than coarse and short fibers. In addition, a high slenderness ratio is likely to result in better yarn regularity along the yarn axis and in the yarn cross-section. This is a direct result of better fiber compactness and doubling effects in the yarn structure. In the end product, high slenderness ratio contributes to the comfort and hand characteristics of textile clothing through easy fiber deflection against human skin.

During processing, fibers are typically compressed, rubbed, stretched, and bent. These various forms of fiber manipulation require fibers of optimum slenderness ratio (not too high and too low). Fibers of very low slenderness ratio are likely to exhibit a discrete flow during processing. This flow is often characterized by a great deal of turbulence, and loss of control. This will lead to a loss of fiber cohesion and fiber continuity, which ultimately could result in spinning failure and high irregularities in the fiber strand (e.g. sliver, roving, and yarn). On the other hand, fibers of very high slenderness ratio will easily be deflected during processing, leading to fiber entanglement or nep formation. For example, the whole concept of air-jet spinning is based on using fibers of high slenderness ratio to provide effective fiber wrapping, a key factor for spinning stability and yarn strength. Fibers of high slenderness ratio will also twist more easily during spinning as a result of their high flexibility. This feature is critically important for effective and economical spinning and for better yarn and fabric quality.

The second qualifying characteristic is flexibility. This is the extent of ease of fiber manipulation under different deformational modes (e.g. tension, compression, bending, and torsion), and under low levels of external loading. The importance of fiber flexibility can be explained in terms similar to those used for the slenderness ratio. Flexible fibers are likely to produce a flexible yarn provided that the binding mechanism used to make the yarn (e.g. twisting, wrapping) is set to retain the flexibility. Although fiber flexibility can partially

stem from a high aspect ratio, different fiber types will also exhibit different inherent flexibility or stiffness levels for a constant value of aspect ratio. As a result, fiber flexibility should be considered as an independent qualifying characteristic. Indeed, it represents one of the key performance criteria for making traditional fibrous products that aim at better fit and more comfort. For function-focused fibrous products, flexibility is a key aspect in meeting manufacturing and fabrication criteria.

The third qualifying fiber characteristic is fiber cohesion reflected by the surface behavior of fibers during processing or during end product use. During processing, fibers are subject to repeated rubbing between each other and against machine parts (wires, rollers, etc.). It is important therefore that they exhibit optimum cohesion to maintain the bulk integrity of the fiber strand, and to allow smooth flow of fibers throughout the different stages of processing. When fibers are converted into a yarn, low fiber cohesion can result in low yarn strength and low breaking elongation. On the other hand, extremely high fiber cohesion can result in a stiff yarn. In the end product, fibers may be blended with other fibers. This requires an optimum surface cohesion compatibility of fibers. During manufacturing, control of fiber surface cohesion is typically achieved through the selection of fibers of appropriate surface morphology (surface structure and cross-sectional shape), the addition of surface treatments, or both.

### 15.2.1 What can be considered fiber damage?

A fiber is described as being damaged when one or more of its basic qualifying characteristics have deteriorated due to external mechanical, chemical, or environmental effects. In this section, the focus will be on the forms of fiber damage and their possible causes.

### 15.2.2 Forms of fiber damage

Fiber damage may take one of the following forms:

- Fiber breakage at some points leading to fiber fragments or short fibers of substantially reduced slenderness ratio
- Over-stretching of fibers resulting in some form of mechanical conditioning; consequently, an alteration of fiber flexibility
- Surface alteration of fibers resulting in loss of surface cohesion or excessive inter-fiber clinging.

The most common form of fiber damage is fiber breakage. Typically, this type of damage occurs when fibers are subjected to harsh impact effects of needles or wires during opening and cleaning or when fibers are stretched beyond their elastic limit and cut during the drafting process. This form

of damage will be the focus of this chapter as discussed in the following sections.

Over-stretching of fibers is also a common form of fiber damage in a typical journey of a fiber through the spinning line. Some studies suggest that a fiber may be subjected to over 10 million contacts by metallic objects such as needles or wires during spinning preparation.<sup>1-3</sup> A great deal of the beating action occurs on fiber fringes that are gripped by the nip of a feed roll of an opening or cleaning unit. This can result in immense loading and unloading of a fiber as it flows from one process to another, an effect that is reduced only by the fact that fibers hardly flow in singles but instead form fiber clusters. This effect is analogous to fiber mechanical conditioning in which fibers are repeatedly loaded and unloaded, resulting in a loss of their elasticity. This type of fiber damage has not been studied to a deserving extent in past investigations and the authors encourage more studies on this critical subject as it relates to critical quality problems that have not been fully resolved. For instance, the fact that a 100% fiber-to-yarn strength efficiency can not be achieved using the current spinning technology is partially a result of the loss of fiber elasticity during spinning preparation.

Surface alteration of fibers commonly occurs for cotton fibers during harvesting and ginning. This type of damage primarily results from the effects of severe environmental conditions, particularly when seed cotton of high moisture content is stored in environments exposed to rain and sun. It can also occur when inappropriate drying is applied on cotton fibers during ginning.

### 15.3 Fiber breakage

Fiber breakage is an inevitable effect that can occur during harvesting, ginning, opening and cleaning, carding, and drafting. Figure 15.1 shows examples of units that can potentially result in fiber breakage. In these units fiber breakage is inevitable by virtue of the fact that the only effective and efficient way to manipulate fibers during spinning preparation is by using opening rolls covered with needles and metallic wires rotating at high speeds. These rolls open and clean the incoming fibers by dividing and re-dividing the fiber stream. In this regard, different types of opening and cleaning units may result in different levels of fiber damage. Opening and cleaning units in which the fibers are entered at free falling (Fig. 15.1(a)), typically result in less fiber breakage than units in which fibers are fed via a feeding roller and a fiber fringe is continuously subjected to beating forces by the opening and cleaning unit (Figs 15.1(b) and 15.1(c)). In this case, the setting between the nip of the feed roll and the beating points is critical in determining the extent of opening and cleaning and simultaneously the extent of fiber damage.

During drafting, the use of a draft setting smaller than the staple length of

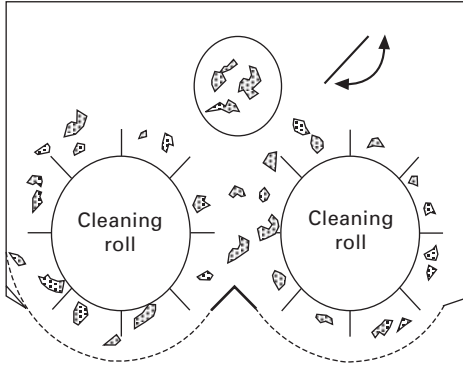

(a) Double-roll cleaner:  
potential mild-medium fiber breakage

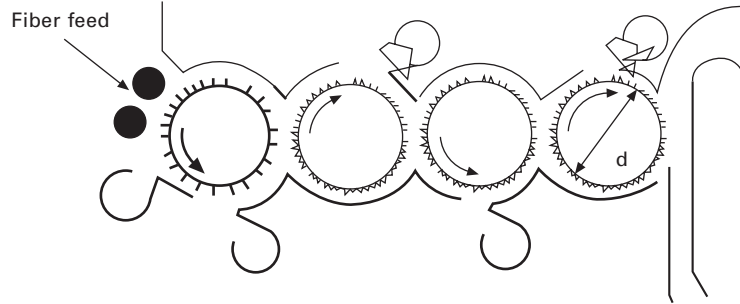

(b) CLEANOMAT multiple-unit system:  
potential severe fiber damage at the feeding zone

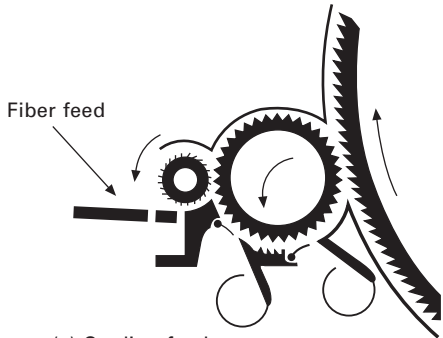

(c) Carding feed zone:  
potential severe fiber breakage

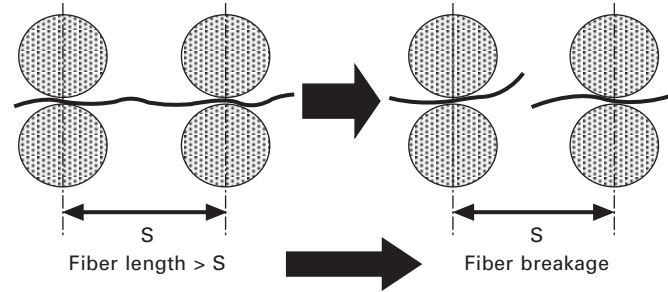

(d) Drafting zones:  
sure fiber breakage when fiber length is larger than the draft setting

15.1 Examples of areas of potential fiber breakage during spinning preparation.

the fiber will surely result in fiber breakage (Fig. 15.1(d)). For this reason, it is important to select an appropriate draft setting. Typically, when a fiber breaks in the drafting zone, its free ends bounce back forming entangled curl or a nep that results not only in loss of fiber contribution but also in increase of yarn irregularity.

Fiber breakage during the spinning or yarn-forming process is expected to be much less than that occurring during spinning preparation (opening, cleaning, and carding). In addition, the potential for fiber breakage will vary depending on the yarn-forming system used. Studies conducted on the extent of fiber breakage during spinning revealed that when the systems are set at optimum conditions for a yarn count of 24's, open-end (rotor) spinning resulted in an increase in short fiber content in the output yarn of about 0.5% and ring spinning resulted in only 0.2% increase.<sup>2,3</sup> This difference was attributed to the use of opening roll in the case of rotor spinning.

In light of the above discussion, minimization of fiber breakage during spinning should be primarily achieved during the spinning preparation process by selecting optimum machine settings, appropriate wire density, appropriate speeds, and an appropriate sequence of opening and cleaning units.<sup>1</sup> A key point in this regard is the trade-off between cleaning and fiber damage. Most standard classing systems are biased to the color and the percent of trash in cotton fibers.<sup>4,5</sup> As a result, excessive lint-cleaning is often applied on the fibers during the ginning process. Commonly, two or three stages of lint cleaning are used after ginning to upgrade the quality of fibers with respect to the classing system, particularly in the area of trash removal and color enhancement. This approach typically results in three major adverse effects:<sup>4</sup>

- Excessive fiber breakage reflected in a high value of short fiber content
- Crushing large trash particles down to smaller trash particles, making it more difficult to remove these particles during spinning preparation
- Excessive neps that must be removed during the carding and combing processes of spinning preparation.

The trade-off between trash removal and fiber damage often continues to the spinning preparation process, as some spinners tend to over-clean the fibers for the sake of trash removal. In this regard, it is important to evaluate the impact of the opening and cleaning action on fiber properties. This can be achieved using two approaches: (1) to evaluate the progressive change in fiber tuft size throughout opening and cleaning, and (2) to evaluate the progressive change in fiber length and fiber neps throughout opening and cleaning.

From opening to carding, tuft size is typically reduced by about 95% to 100% by weight from the first opening point to the final opening point (i.e.

the carding licker-in). This significant reduction should be achieved using a carefully designed stepwise opening process in which the tuft size is gradually reduced.<sup>6,7</sup> As shown in Fig. 15.2, the rate at which the tuft size is reduced throughout the opening process is a critical criterion of the effectiveness of cotton opening. In practice, optimum rates are achieved using a predetermined sequence of opening units with coarse openers positioned in the early stage, and finer openers positioned toward the final stage. Coarse opening units may consist of short or thin fingers, or partially pinned blades. Fine openers typically consist of medium to fine saw-tooth wires. Intermediate openers may consist of pins, needles, or coarse saw-tooth wires. A steep reduction in tuft size using fewer intense units, or fine openers in the early stage of opening, will result in excessive fiber breakage and crushing of large trash particles, making their removal in subsequent stages a very difficult task. On the other hand, a drain opening, as defined by machine makers, is one in which a large number of units is used. This type of opening, in addition to its high cost, will result in overworking the fibers. This can lead to fiber breakage and loss of fiber elasticity. It should be noted that the optimum tuft size produced by an opening unit is a function of a number of factors, including throughput rate, the circumference speed of the opening roll, and the number of different working elements (teeth or pins) per unit area. In relation to material, different cotton types may have different opening propensity depending on a number of factors, including the fiber density, fiber friction, resiliency, length, fineness, the nature of foreign matter, and the degree of entanglement between fibers and other embedded material in the cotton stock.<sup>1</sup>

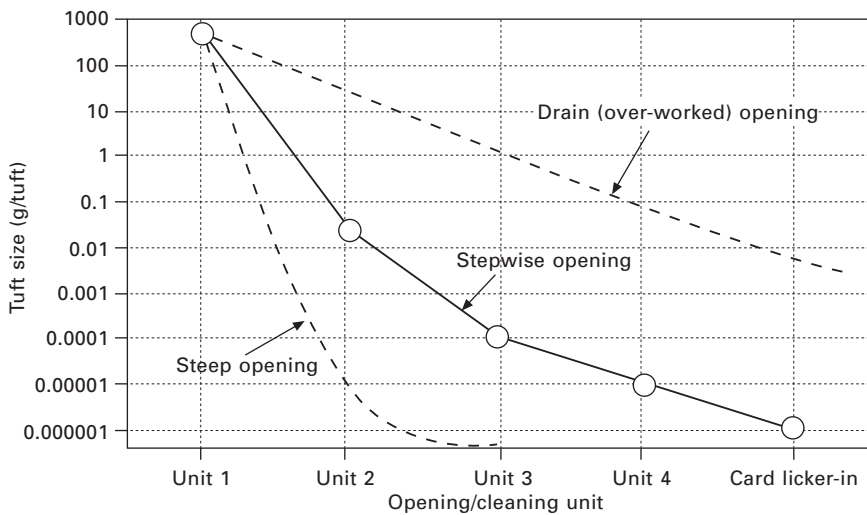

15.2 The concept of stepwise opening (modified after Reference 6).

In practice, the degree of opening may be determined by comparison of the density of fiber material before and after opening. In this regard, the following equation is useful:<sup>1</sup>

$$\text{Degree of opening} = \frac{\mathbf{r}_{\text{input stock}} - \mathbf{r}_{\text{output stock}}}{\mathbf{r}_{\text{input stock}}} \times 100 \quad 15.1$$

The above equation indicates that an ideal opening (approaching 100%) will yield very small values of density of output stock. In situations where no opening occurs, the density of output stock will be equivalent to that of the input stock. This will yield a zero degree of opening. In practice, the density of a fiber stock can be roughly estimated by weighing the fiber material that can fill a container (e.g. a sliver can) of a constant volume under its own weight (i.e. no packing pressure imposed).

Evaluation of the progressive change in fiber length represents the reference approach to determining the extent of fiber breakage. This evaluation can be carried out during opening and cleaning and also during drawing as discussed below. The availability of efficient and accurate fiber length testing techniques makes this evaluation an easy task. The advanced fiber information system (AFIS<sup>®</sup>) developed by Uster Technologies represents a powerful tool in this regard.

Any cleaning process should be evaluated in view of the following basic criteria:

- Cleaning efficiency and cleaning intensity
- The extent of fiber damage.

The concept of cleaning efficiency is illustrated in Fig. 15.3. Several expressions may be used to characterize the cleaning efficiency of a cleaning unit. Accordingly, one has to specify the expression used to characterize the cleaning performance when values are presented. One of the expressions used to characterize cleaning efficiency (CE) is as follows:<sup>1,5,6</sup>

$$\text{CE (\%)} = \frac{T_w}{W} \times 100 \quad 15.2$$

where  $T_w$  is the amount of trash extracted, and  $W$  is the total amount of waste (fibers plus trash).

The expression above indicates that a highly efficient cleaning unit will produce waste that has much more trash particles than pure fibers. By this expression, a 100% cleaning efficiency would mean that the waste produced by the cleaning unit consists entirely of trash particles, while a totally deficient cleaning machine will produce waste entirely consisting of pure fibers. Obviously, these two extremes do not exist in practice, and a typical cleaning unit will exhibit intermediate values.

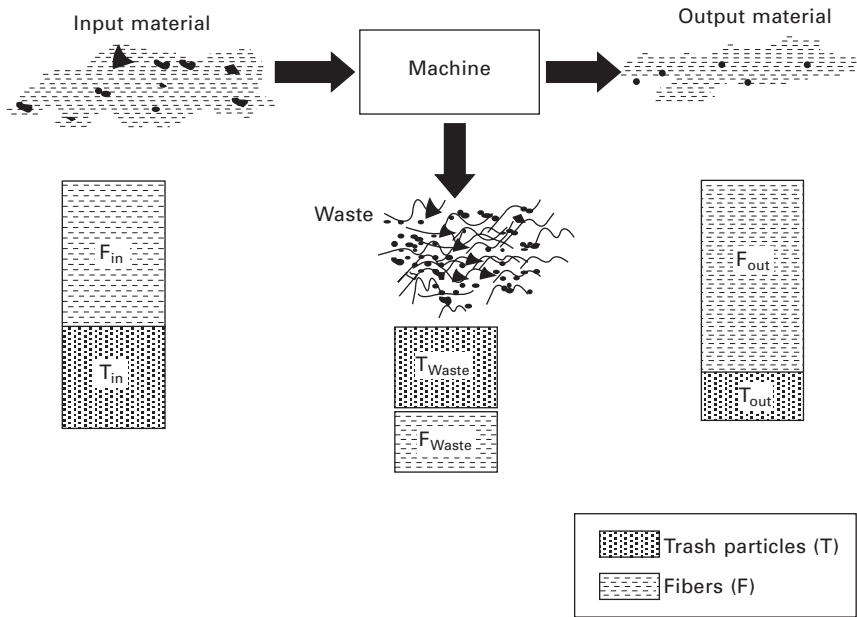

15.3 Relative amounts of fibers and trash at different points of a cleaning unit.

Another important term used in waste and trash removal analysis is the so-called cleaning intensity (CI) or the degree of cleaning. This is expressed by the following equation:<sup>1</sup>

$$CI (\%) = \frac{T_{in} - T_{out}}{T_{in}} \times 100 \tag{15.3}$$

This equation indicates that a maximum cleaning intensity of 100% will be in a situation where the output trash is virtually zero. Again, this represents a theoretical situation, and typical values are expected to be below this level.

The performance of a cleaning unit cannot be fully characterized without careful consideration of the effect of cleaning on fiber quality, particularly the potential fiber damage that can be caused by a severe interaction between the cleaning elements and the fibers. As indicated earlier, it is inevitable that any cleaning process that involves mechanical action will be associated with some fiber breakage.

In practice, the extent of fiber fragmentation by an opening and cleaning unit is typically determined by testing short fiber content in both the input and the output material. If a cleaning unit caused severe fiber fragmentation, the output material would have much higher short fiber content than the input

material. In addition, the mean length of the output material will be smaller than that of the input material. This situation is illustrated in Fig. 15.4(a).

In some situations, short fiber content in the output material is found to be slightly lower than that of the input material as shown in Fig. 15.4(b). Assuming no testing error is involved, this situation is often a result of the extraction of short fibers with the machine waste (Fig. 15.4(c)). Using the mass conservation law (Fig. 15.5), we developed the following simple expression to account for the extraction of fiber fragments in the waste:<sup>1</sup>

$$\text{EFD (\%)} = 100 \frac{\widehat{\text{SFC}}_{\text{out}} - \widehat{\text{SFC}}_{\text{in}}}{\widehat{\text{SFC}}_{\text{in}}} + \text{CF}_w \quad 15.4$$

where EFD is the extent of fiber damage,  $\widehat{\text{SFC}}_{\text{out}}$  is the percent short fiber content in the output material,  $\widehat{\text{SFC}}_{\text{in}}$  is the percent short fiber content in the input material, and  $\text{CF}_w$  is a correction factor which accounts for the short fiber content extracted with the waste. This correction factor can be determined from the following equation:

$$\text{CF}_w = W(\%) \frac{\widehat{\text{SFC}}_w - \widehat{\text{SFC}}_{\text{out}}}{\widehat{\text{SFC}}_{\text{in}}} \quad 15.5$$

where  $\widehat{\text{SFC}}_w$  is the percent short fiber content in the waste material, and  $W$  is the percent waste.

Figure 15.6 illustrates the use of the above equation using two different examples. Notice that we assumed all fibers in the waste to be short fibers. Under normal cleaning conditions, this is typically the case. We also assumed that a perfect cleaning efficiency of 100% does not exist. In other words, any cleaning unit will extract some fibers with the trash. Under a hypothetical case of 100% cleaning efficiency, the correction factor  $\text{CF}_w$  will have no meaning.

With regard to fiber neps, it is generally expected that the number of neps per unit weight will increase during opening and cleaning. In the carding process, proper settings and optimum conditions of carding wires will result in a great deal of nep removal. The extent of nep formation or nep removal is known as nep removal efficiency (NRE). This can be determined from the following equation:<sup>1</sup>

$$\text{NRE (\%)} = \frac{|(\text{neps/g})_{\text{in}} - (\text{neps/g})_{\text{out}}|}{(\text{neps/g})_{\text{in}}} \times 100 \quad 15.6$$

Notice that we used the absolute value of nep change. Typically, a cleaning unit in the opening line will result in a negative change, or an increase in nep count upon cleaning. The carding or combing machine will result in a positive change as a result of the expected reduction in nep count in the output material. Typical values of nep removal efficiency may range from

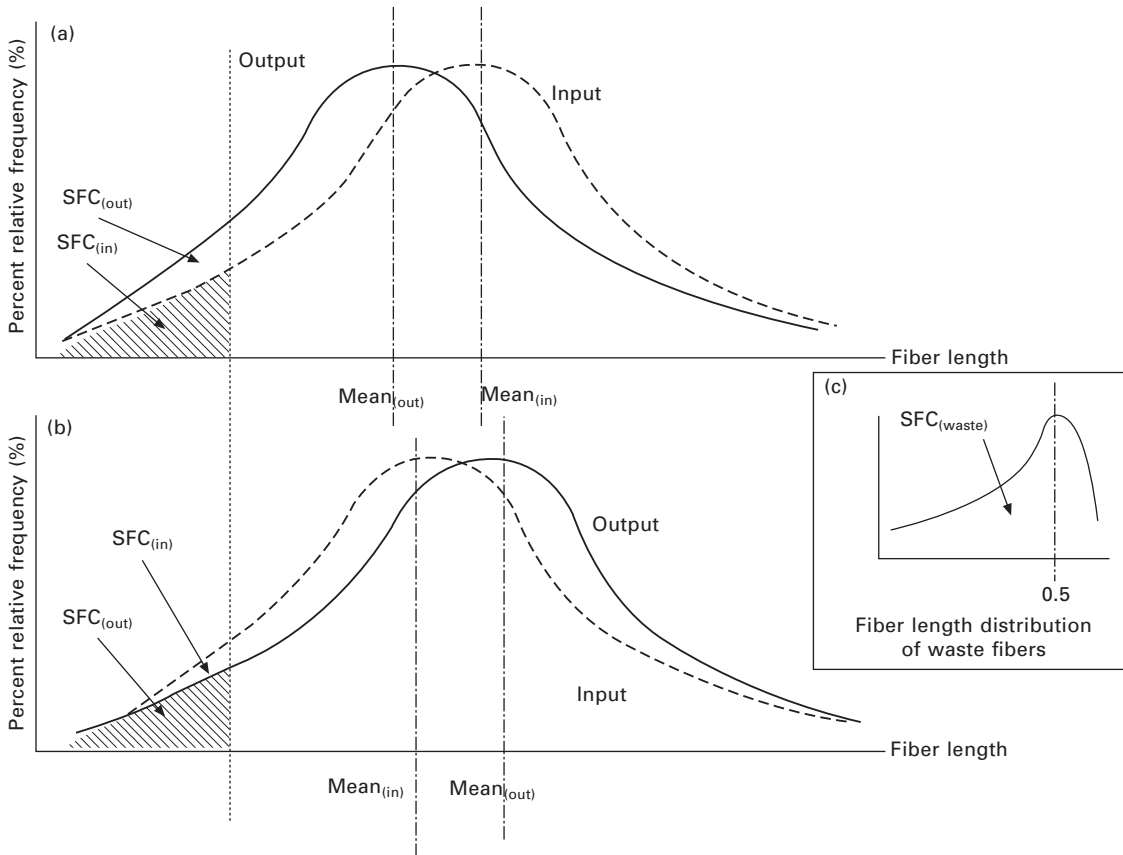

15.4 Possibilities of change in short fiber content upon cleaning.

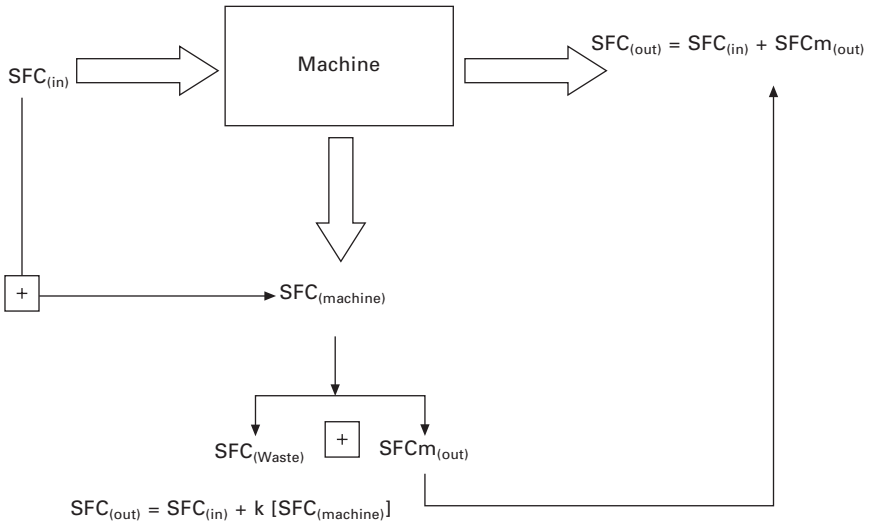

**15.5 Short fiber conservation rule.**

Example 1:

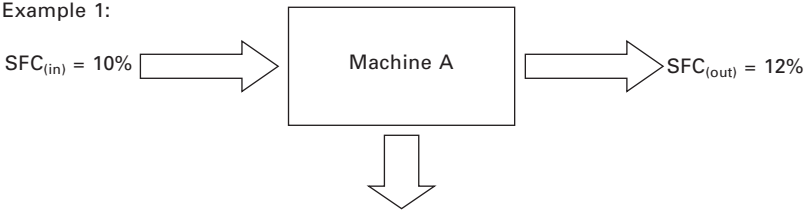

Waste = 5% = Trash (60%) + Short Fibers (40%)

$$EFF = 100 [12 - 10]/10 + 5 [40 - 12]/10 = 34\%$$

Example 2:

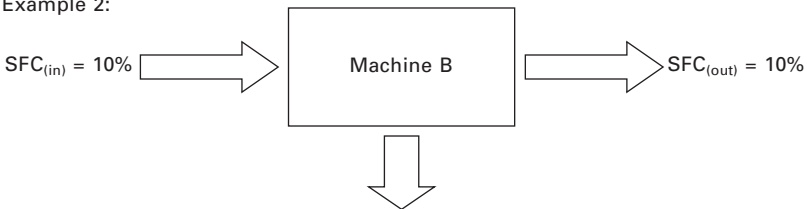

Waste = 5% = Trash (60%) + Short Fibers (40%)

$$EFF = 100 [10 - 10]/10 + 5 [40 - 10]/10 = 15\%$$

**15.6 Extent of fiber fragmentation.**

40% to 90% for the carding machine, and from 50% to 70% for the combing machine.

The methods described above can also be used to evaluate the extent of

fiber breakage and nep formation upon drawing. It should be pointed out, however, that the way fiber lengths change upon drawing is different from that resulting from opening and cleaning. Typically, the drawing process results in an increase in the fiber mean length as a result of straightening the fibers and the removal of fiber crimp. This effect can be described by the so-called ‘sliver orientation index, SOI’ developed by Elmogahzy:<sup>1</sup>

$$\text{SOI} = \frac{\text{MFL}_{\text{output}}}{\text{MFL}_{\text{input}}} \quad 15.7$$

where MFL = mean fiber length.

Upon drawing, the expected value of SOI should be greater than 1. A value of SOI of less than 1 will indicate a deficiency in sliver orientation in spinning preparation, or in the context of this chapter it could imply some fiber breakage leading to a reduction in fiber mean length. A typical SOI value at the breaker drawing stage is about 1.15, implying an increase in mean fiber length of 15%. In the finisher drawing, the SOI value is typically the same or slightly less.

When fiber damage is evaluated during the combing process, it should be realized that this process typically removes short fibers and neps by virtue of the principle of combing.<sup>1</sup> As a result, the extent of fiber damage should be largely based on the quality of noils removed during combing in comparison with the input sliver. The equation of the extent of fiber damage described earlier can be very useful in this regard.

## 15.4 Fiber damage in the yarn-forming process

The discussion above explains why most fiber breakage will occur during spinning preparation. During yarn forming or spinning, fiber damage can also occur in different modes depending on the type of spinning. In this section, potential fiber damage in different spinning systems is reviewed.

## 15.5 Fiber damage in ring and compact spinning

Fibers enter the ring spinning system in a roving form – a thin fiber strand that is lightly twisted. The average number of fibers per cross-section of this fiber strand may fall between 3000 to 5000 depending on roving count and fiber fineness. This number must be reduced down to only a few fibers (100 to 700) in the final yarn. This reduction is achieved by an inclined drafting system (see Fig. 15.7) in which the break draft zone (or first draft zone) is critical as it has to apply a low draft (slightly greater than 1), enough to remove the light twist in the roving. A critical factor in this regard is the level of twist in the roving; hard twist could result in a higher drafting

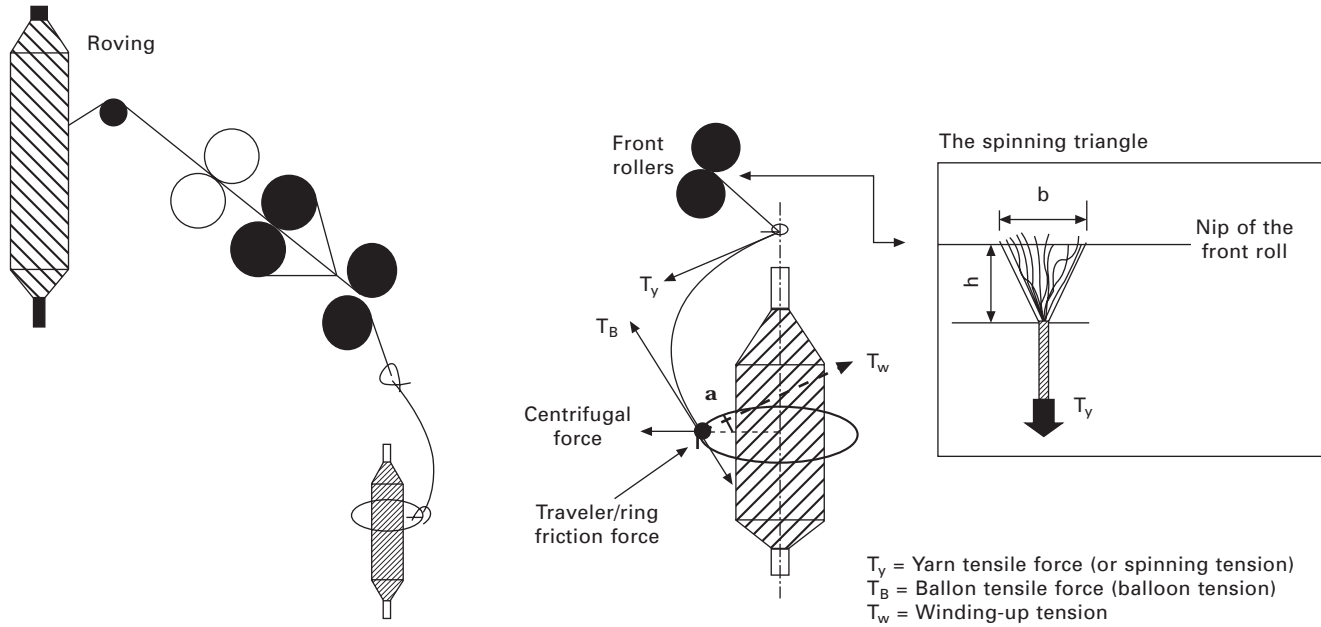

15.7 Different forces applied on the fibers during ring spinning.

force with greater potential for fiber breakage.<sup>1</sup> Fibers leaving the draft zone are twisted into a yarn using a ring-traveler system as shown in Fig. 15.7. This brings about another critical zone of potential fiber damage, which is the so-called spinning triangle. This is the final stage in which fibers are represented as single fibers before they are consolidated into a yarn. The key factor influencing fibers in this zone is the spinning tension,  $T_y$ , defined by the following equation:

$$T_y = \frac{\mathbf{m}_t m_t V_t^2}{d_r \sin \mathbf{a}} \quad 15.8$$

where  $\mathbf{m}_t$  = the coefficient of friction between ring and traveler,  $\mathbf{a}$  = the angle between yarn from traveler to bobbin and a straight horizontal line from traveler to spindle axis,  $m_t$  = traveler mass,  $V_t$  = traveler speed, and  $d_r$  = ring diameter. Note that the term  $(m_t V_t^2 / d_r)$  represents the centrifugal force applied on the traveler and yarn during rotation.

In practice, spinning tension is defined as the tensile force applied on the yarn at the onset of twisting: that is, the yarn tension at the point where the fibers in the spinning triangle are being twisted (see Fig. 15.7). The critical importance of this parameter lies in the fact that it contributes largely to both the quality of ring spun yarn, and the spinning performance. High spinning tension results in a closed packing of fibers during twisting, which enhances the yarn strength. Variation in spinning tension directly results in variation in yarn strength. Excessive tension or tension peaks may result in fiber damage and end breakage during spinning. In fact, more than 80% of end breakage during ring spinning is believed to result from tension peaks at the spinning triangle.

In the context of fiber breakage, understanding the fiber behavior in the spinning triangle will assist in minimizing fiber damage. As indicated above, the spinning triangle represents the final stage of fiber/machine interaction in the ring-spinning line. In this triangle, different fibers have different tensions depending on their position in the triangle. Fibers in the center of the triangle are usually slack and those in the outer layers are under maximum tension. When fibers are released from the nip of the front roller, those exhibiting high tension tend to move toward the center, displacing the initially central fibers to the outer layers. This phenomenon is called 'fiber migration' and its main effect is to enhance fiber cross-linking, and consequently to improve yarn strength.<sup>1</sup>

The dimensions of the spinning triangle (width and height) determine the extent of fiber/machine interaction in this critical zone. The width of the triangle,  $b$ , represents the width of the fiber bundle nipped by the front roller, and the height,  $h$ , represents the length from the nip of the front roller to the twisting point (see Fig. 15.7). Normally, the width of the triangle is a function of the amount of draft or the total number of fibers delivered, and

the pressure on the front roll. The height of the triangle, on the other hand, is quite sensitive to the spinning tension.

Variations in fiber length and fiber displacement in the draft zone typically result in three different fiber arrangements in the spinning triangle (Fig. 15.8):

- $n_1$  = fibers only held at one end by the nip of the front roller while the other end is free
- $n_2$  = fibers only held at one end by the twisting point while the other end is free
- $n_3$  = fibers held by both the nip of the front roller and the twisting point (i.e. fibers firmly held by the triangle). Those fibers exhibit a mean fiber length longer than the height of the spinning triangle.

Any fiber entering the spinning triangle that does not belong to any of the above categories will typically be too short (fiber fragment) and, if not held by other fibers, will likely result in fly generation.

In order to understand the significance of the above classification, one must think of the spinning triangle as being a battlefield in which two forces are acting against each other: the spinning tension  $T_y$  and the fiber strength  $T_f$ . In a situation where a perfect dynamic balance is achieved, all fibers in

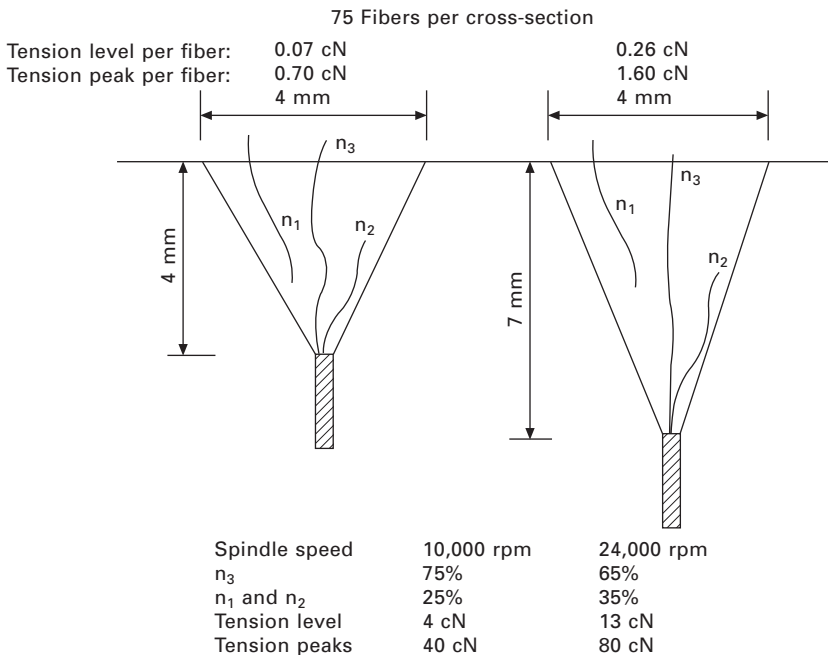

15.8 Effect of spindle speed on the spinning tension.<sup>8</sup>

the spinning triangle will equally share the support of the spinning tension. This situation is likely to occur when all fibers in the triangle belong to the  $n_3$  group. If the majority of fibers in the triangle belong to the other two groups, a smaller number of fibers will be supporting the load exerted by the spinning tension. This situation may result in tension peaks and a spinning failure or end breakage at the spinning triangle.

The above discussion suggests that the spinning triangle should have optimum dimensions to allow spinning stability and minimum fiber breakage. In particular, the triangle should not be too small to provide room for fiber exchange of position (fiber migration), and not too large to allow the majority of fibers to be held in the triangle (to avoid high hairiness). This latter point was the driving force of a new ring-spinning development called 'compact' spinning, as will be discussed later in this section.

Since the spindle drives the traveler, an increase in spindle speed will result in a corresponding increase in the traveler speed. The effect of spindle speed on spinning tension is a direct result of its effect on the dimension of the spinning triangle.<sup>8</sup> Figure 15.8 shows the dimensions of the spinning triangle at two different levels of spindle speed, 10,000 rpm and 24,000 rpm, for a given fiber length. As can be seen in this figure, at a spindle speed of 10,000 rpm, the height of the spinning triangle was 4 mm. This resulted in about 75% of the fibers in the triangle being firmly held by the two ends of the triangle. When the spindle speed was increased to 24,000 rpm, the height of the spinning triangle was increased to 7 mm, leading to a reduction in  $n_3$  to 65%. The corresponding increase in the average level of spinning tension was from 4 cN to 13 cN. This increase resulted in an increase in the tension peak from 40 cN to 80 cN.

In light of the above discussion, it follows that the increase in spindle speed, which is a requirement for the increase in the production rate in ring spinning, will result in an increase in the height of the spinning triangle, and the spinning tension. This means that the increase in spindle speed in ring spinning imposes additional constraints on fiber quality; it requires longer and stronger fibers to maintain an acceptable spinning stability and to avoid fiber damage.

Compact or condensed spinning is a new concept of yarn forming. It represents a fundamental modification of the conventional ring-spinning system that aims at producing a better surface integrity of spun yarns and maximizing the fiber contribution to yarn strength. The idea stems from the point made earlier about the necessity of controlling the dimensions of the spinning triangle to improve yarn strength and reduce yarn hairiness.

In simple practical terms, it is well known that one of the features of conventional ring spinning is that the width of the fiber strand undergoes dynamic changes as fibers flow from the drafting zone to the twisting zone (see Fig. 15.9). In the drafting system, the width of the fiber strand ( $W_F$ )

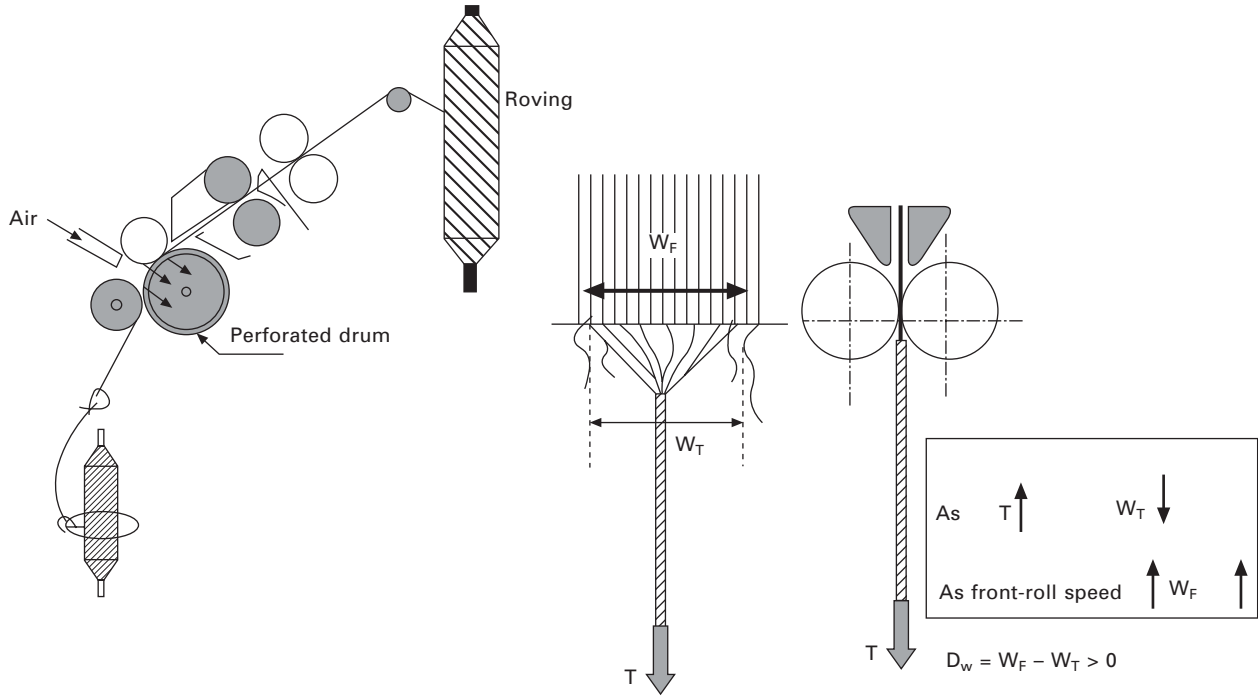

### 15.9 Compact (condensed) spinning.

$W_F = f$  (yarn count, roving twist, total draft ratio, spinning tension T)

is large. As the fibers emerge from the nip of the front drafting rollers, the width decreases to the width of the spinning triangle ( $W_T$ ). Finally, as the fibers enter the twisting point, the width of the strand is reduced further to the thickness of the yarn being formed. The continuous change in the width of fiber strand associated with the tension differential across the fiber flow results in a divergence of some fibers (particularly the edge fibers) from the main fiber stream. This prevents some fibers from being fully incorporated in the yarn structure. Those fibers will not fully share the loading of yarn under tensile stresses, leading to a loss in yarn strength. Furthermore, they are likely to form protruding hairs that can be stimulated further by the ring/traveler system.

In general, the difference between the width of the fiber flow,  $W_F$ , in the drafting system and the width of the spinning triangle,  $W_T$ , widens as the speed of the front roller increases or as the spinning tension increases. The former is due to the loss of fiber control, and the latter is due to the reduction in the spinning triangle width ( $W_T$ ). The problem with the difference,  $D_w$ , is that the spinning triangle cannot catch all the incoming fibers. This means that some edge fibers will be under no tension control. Those fibers will not have the opportunity to fully migrate into the yarn, and in a worst-case scenario, either they are lost or they wrap around the already twisted yarn in a disorderly arrangement. The effect of those fugitive fibers on yarn quality will be reflected in high hairiness, low strength and low evenness.

One way to minimize the  $D_w$  difference is by condensing the fiber flow at the nip of the front roll. The ways by which the fibers can be condensed are many.<sup>9</sup> One conventional way is to increase the twist in the roving to an optimum level that will allow better compactness of the fibers during the drafting process (that is, keeping the fibers sideways together). This method suggests that the roving twist can act as a fiber condenser, mainly in the break-draft zone, and partially at the main draft zone. Another method of condensation is to use mechanical means, for example a funnel-shaped condenser located between the aprons and the delivery cylinders. Such an element can in fact add a condensation effect to the fiber flow. The only disadvantage is that due to the rubbing action between the funnel and the fibers the drafting action is disrupted, leading to deterioration in yarn evenness, increase in imperfections, and possible fiber damage. The third possibility is by using aerodynamic condensation after the drafting zone, but before the yarn formation, which is the principle of compact spinning shown in Fig. 15.9.

## 15.6 Fiber damage in rotor spinning

In rotor spinning, the incoming fiber strand (sliver) is much larger than that in ring spinning as it may contain 20,000 to 40,000 fibers per cross-section.

As a result a great deal of drafting is required. This is typically achieved using three operations:<sup>10-12</sup> (1) mechanical opening using an opening roll, (2) air drafting using an air stream in a transporting duct, and (3) a doubling mechanism. The use of a sliver requires a large amount of draft to reduce its size down to that of the yarn size. Before the large number of fibers is reduced to a value of about 100 fibers per cross-section in the yarn, it must first be reduced to as low as two fibers (a draft ratio of 10,000:1). This substantial reduction requires high-speed mechanical drafting boosted by air drafting (Fig. 15.10).

In the context of fiber damage, since the mechanical drafting is achieved using a toothed opening roll, inappropriate setting of this roll can result in substantial fiber damage. This opening roll separates the fibers in the sliver and allows removal of trash. This means that the extent of damage will depend on the level of trash in the incoming sliver. Fibers coming out of the opening roll are airborne through an air duct. This zone of draft is of special significance because of its impact on fiber orientation. A turbulent airflow will result in some fiber disorientation. This could partially result in a weak yarn.

In order to minimize fiber disorientation, the airflow in the duct should have a velocity exceeding that of the surface speed of the opening roll. To obtain such an airflow, the inside of the rotor is run at a vacuum, which may be achieved by designing the rotor with radial holes to allow the rotor to generate its own vacuum (self-pumping effect). Alternatively, an external pump can be used. Fibers in the duct should have a smooth and straight flow. Therefore, the air duct may be designed in a tapered shape toward the rotor to allow acceleration of the fibers as they approach the rotor's inside surface. This action also allows straightening of leading fiber hooks coming out of the opening roll.

Since consolidation in rotor spinning is achieved at minimum tension, the concerns of spinning tension that we had earlier with ring spinning do not exist with rotor spinning. However, the loss in tension results in a unique structure of this type of yarn in which fiber contribution is less than that of ring spinning. As a result, rotor spun yarns, are generally weaker than comparable ring spun yarns not due to fiber damage but rather due to loss of fiber contribution.<sup>1,10</sup>

## 15.7 Fiber damage in friction spinning

In friction spinning, drafting is achieved using an opening roll or a drafting roll system. Accordingly, forms of fiber damage associated with these two systems discussed earlier are applicable for friction spinning. In friction spinning, the incoming fiber strand may be in the form of a single sliver, a number of slivers, or a combination of a sliver and continuous filament

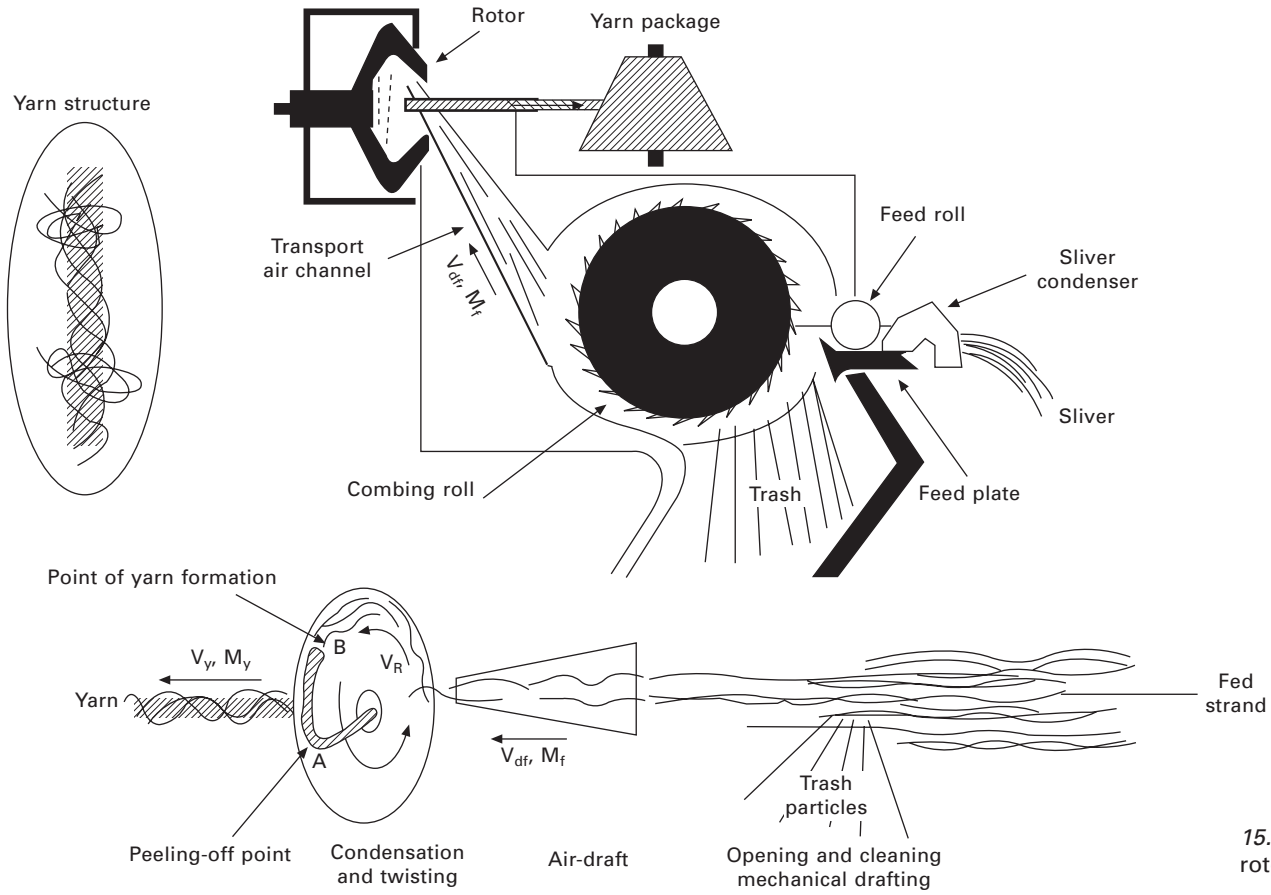

15.10 Principle of rotor-spinning.

yarn.<sup>13–20</sup> The consolidation mechanism is achieved by twisting fibers against friction drums. Upon drafting of the input sliver, fibers are carried by means of an air current to a collecting point between two friction drums rotating in the same direction. At this point, twisting forms the yarn. The twist is imparted by the relative rotation between the surface of the drums and the yarn. Thus, the rotating element in this case is the yarn itself with a very high rotational speed due to the very high drum/yarn diameter ratio.

In the context of fiber damage in friction spinning, two basic factors should be discussed:<sup>16–20</sup>

- Fiber landing mechanism
- Twisting mechanism.

The way fibers are deposited or landed on the friction drum largely determines the structure of friction spun yarns. Fiber landing on the friction drum (the consolidation unit) is quite different from fiber landing on the rotor in rotor spinning. This difference is illustrated in Fig. 15.11. Both systems use an air duct to transfer the fibers from the mechanical drafting unit (opening roll) to the spinning unit. However, the landing pattern is substantially different. In rotor spinning, individual fibers flowing through the air duct are accelerated as they approach the rotor. The level of twist (the rotational speed of the rotor) and the spinning tension positively control the ratio between the number of fibers per yarn cross-section and the number of fibers approaching the rotor. The doubling effect resulting from the fiber condensation in the rotor's inside surface, and the existence of centrifugal force on the fiber mass assists in improving both the uniformity and the fiber packing in the yarn.

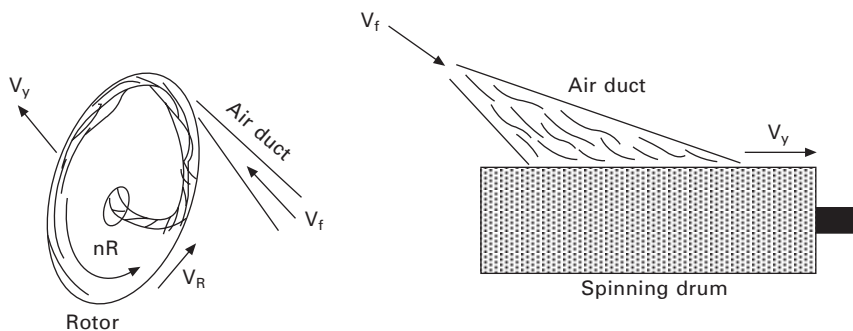

- (a) Fiber landing in rotor spinning:
- Fibers are accelerated through the air duct.
  - Fibers are drafted when joining the fiber assembly in the rotor.
  - Doubling effect.

- (b) Fiber landing in friction spinning:
- Fibers are slowed down.
  - Fibers are compressed when joining the fiber assembly on the drum.
  - Irregular doubling and positioning of fibers in the yarn.

15.11 Comparison of fiber landing in rotor and friction spinning.

In friction spinning, fibers coming from the opening unit approach the spinning unit at a higher speed than the outlet speed of the yarn. This results in a compressive action as the fibers touch the nip between the friction drums. This compressive action results in a great deal of fiber disorientation or fiber looping. This is a unique type of fiber damage as it results in fiber looping and a substantial loss in fiber contribution to the yarn. As a result friction spinning is typically specialized in making very coarse yarns with large numbers of fibers per cross-section to compensate for this loss of fiber contribution. In practice, weak zones are often observed in friction spun yarn. These zones are found in lengths ranging from 3 to 10 mm (at regular intervals of 0.5 to 1 meter). Typically, the number of fibers in the cross-section of these zones is lower than the nominal number (determined by yarn count). More studies need to be carried out on evaluating these zones in the context of fiber damage.

The twisting mechanism in friction spinning is achieved by feeding the fibers into the nip of two spinning (friction) drums, which rotate them to form the yarn. The resulting twist, however, does not correspond to the ratio of yarn diameter to drum diameter because of the slippage effect, which can lead to a loss of up to 60%. The problem associated with fiber landing discussed above adds to the problem of twist loss by introducing a great deal of twist variability.

In the absence of a significant spinning tension during twisting, it becomes critically important to control the fibers as they are rotated in the twisting zone. This control is achieved by applying equal frictional forces on the two contact areas between the fibers and the spinning drums (see Fig. 15.12). The yarn/drum friction force is determined by the classical Amonton's law,  $F = \mu N$ , in which  $\mu$  is the coefficient of friction between the fiber surface and the drum surface, and  $N$  is the normal force applied on the area of yarn/drum contact. The normal force is exerted by the air evacuation, which results in fastening the fibers to the drum surface during twisting. The use of two friction drums allows equal normal force application on the two contact areas. In addition, the friction coefficients of the two friction drums should be of equal value.

## 15.8 Conclusion

This chapter deals with the subject of fiber damage during spinning. Fiber damage is classified into many forms such as fiber breakage, loss of elasticity, surface deterioration, and fiber neps. Fiber damage is defined as a substantial change in one or more of the basic fiber characteristics that can result in a loss of fiber contribution to yarn or fabric performance. Most fiber damage occurring in the spinning process takes place during the preparatory stages of fiber strand and prior to the yarn-forming stage. This is a result of the

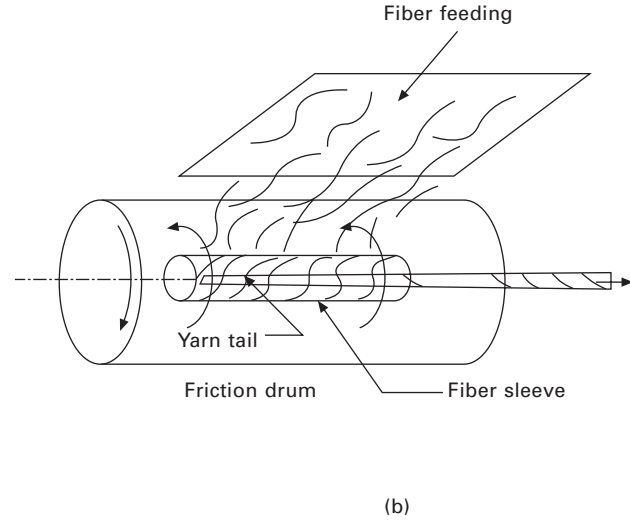
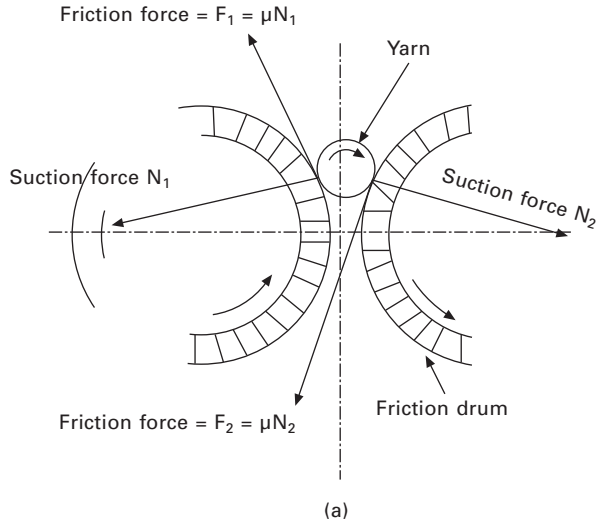

15.12 Principle of twisting in friction spinning.

trade-off that must take place between the need to open the fiber stock and the need to handle the fiber stock extensively. Since opening and cleaning of the fiber stock is achieved primarily using mechanical means (e.g. opening and carding rolls covered with wires and needles), fiber breakage is an inevitable outcome. Other forms of fiber damage include loss of fiber elasticity, and surface deterioration.

A fiber is described as being damaged when one or more of its basic qualifying characteristics have deteriorated due to external mechanical, chemical, or environmental effects. In this regard, fiber damage may take one of the following forms:

- Fiber breakage at some points leading to fiber fragments or short fibers of substantially reduced slenderness ratio
- Over-stretching of fibers resulting in some form of mechanical conditioning; consequently, an alteration of fiber flexibility
- Surface alteration of fibers resulting in loss of surface cohesion or excessive inter-fiber clinging.

The focus of this chapter was on the most common form of fiber damage, which results from fiber breakage occurring when fibers are subjected to harsh impact effects of needles or wires during opening and cleaning or when fibers are stretched beyond their elastic limit and cut during the drafting process. Different zones in the spinning process in which potential fiber damage can occur were reviewed and ways to measure the extent of damage in these zones were discussed.

## 15.9 References

1. Elmogahzy, Y., and Chewning, C., Jr, *Fiber To Yarn Manufacturing Technology*, Cotton Incorporated Publication, Cary, NC (cottoninc.com), 2001.
2. Elmogahzy, Y. and Broughton, R., Jr, preparatory processing performance and blending efficiency of cotton fibers, *Melliand*, No. 4, E52–E54, G212–G218, 1995.
3. Elmogahzy, Y. Broughton, R., Jr, Guo, H., and Taylor, R., Evaluating staple fiber processing propensity, Part I: Processing propensity of cotton fibers, *Textile Res. J.*, 68(11), 835–840, 1998.
4. El Mogahzy, Y., Kearny, R., and Lynch, K., Effects of lint cleaning on processing performance, and yarn quality, Final Report submitted to USDA, SRRC, New Orleans, LA, 1992.
5. Elmogahzy, Y., Broughton, R. and Lynch, K., A statistical approach for determining the technological value of cotton using HVI fiber properties, *Textile Res. J.*, 60(9), 495–500, 1990.
6. Leifeld, F., Modern spinning preparation. Part A: Blow room and carding machines, systematically correlated, *German Technology Symposium & Exhibition*, Bangkok, Thailand, November 1993.
7. Leifeld, F., New features of a high-tech card, paper presented at the Beltwide Cotton Conference, San Diego, CA, 1994.

8. Schonung, B., and Bay, E., First results with individual motor-driven ring spindles, Lecture on the occasion of the 4th Ring-spinning Colloquium in Eningen unter Achalm, Germany, SKF Publications, 1989.
9. Stalder, H., Compact spinning – a new generation of ring-spun yarns, *Melliand*, No. 3, E29–E31, 1995.
10. Deussen H., *Rotor Spinning Technology*, Schlafhorst, Inc., Charlotte, NC, 1993.
11. Deussen, H., Some thoughts on the role of cotton in new spinning technologies, Presentation to the Cotton Spinners and Cotton Growers Conference in Lubbock, TX, 1984.
12. Artzt, P., Muller, H. and Joas, W., Possibilities of assessing the yarn structure of rotor-spun yarns, *Int. Textile Bull.*, 4, 45–51, 1989.
13. Krause, H. W. and Soliman, H. A., The yarn formation in friction spinning, *Int. Textile Bull.*, 4, 31–42, 1989.
14. Brockmanns, K. J. and Lünenschloss, J., Part I: Friction spinning analyzed, *Int. Textile Bull.*, 2, 5–23, 1984.
15. Brockmanns, K. J. and Lünenschloss, J., Part II: Friction spinning analyzed, *Int. Textile Bull.*, 3, 15–29, 1984.
16. Lünenschloss, J., and Brockmanns, K. J. Mechanisms of OE-friction spinning, *Int. Textile Bull.*, 3, 29–59, 1985.
17. Fehrer, E., The present state-of-the-art in friction spinning, *American Textile International*, 86–89, December, 1986.
18. Stalder, H. and Soliman, H. A., A study of the yarn formation process during friction spinning, *Melliand*, No. 2, E44–E46, 1989.
19. Brockmanns, K. J. and Johnson, N., The influence of fiber feeding arrangements on the properties of friction spun yarn, *Int. Textile Bull.*, 3, 27–34, 1986.
20. Brockmanns, K. J., Possibilities of OE-friction spinning, *Textile Month*, 10–16, December 1984.

---

I. A. ELHAWARY, Alexandria University, Egypt

**Abstract:** Artificial fibres require spin finishes for conversion into textile materials for various applications and efficient operation. Although a spin finish on a fibre surface might be only a few molecules thick, it is one of the most important parameters affecting the quality and performance of the processing. This chapter covers several aspects of spin finishes, such as components and key requirements, quality issues in their use, etc., and ends with a short survey of testing methods.

**Key words:** spin finishes, components, applications, quality issues, cotton, wool, synthetic, spinning systems, testing.

## 16.1 Introduction

A spin finish is a liquid or solid composition that is applied to the surfaces of man-made fibres in order to improve the processing of such fibres in short-staple or long-staple spinning. The following terms are all used to define the same thing: spin finish, spinning finish, waxing, size, dressing, coating, fibre finish, spinning lubricant, agent, textile treating composition, textile treating agent and condition agent (Behery and Demir 1997).

An electrostatic charge is generated on fibre surfaces during processing due to friction between the fibres themselves or between them and parts of the spinning machinery with which they come into contact. This charge can cause major problems in processing. Static electricity causes fibres to attract or repel one another, disrupting yarn formation. It can also cause fibres to stick to other surfaces such as machine parts. In addition, it is important that synthetic fibres used for producing fabrics, particularly household or industrial fabrics, have optimum antistat friction properties if they are to perform properly in use.

The primary function of a spin finish is to eliminate the build-up of static electric charges on fibres during processing. This is achieved in two ways. First, the finish makes the fibre hydrophilic in order to facilitate charge dissipation (leakage). Second, it reduces the static and dynamic friction of the fibres, and subsequently the yarns, while they are moving in contact with machine parts, diminishing the generation and build-up of charge.

Spin finishes can also control the amount of friction during processing. As an example, yarns experience drag as they pass over a ceramic guide or pass

through the traveller during ring spinning. If the drag is too great, due to the degree of friction between fibres and machinery, fibres can be damaged. A spin finish can reduce the amount of friction to a level which avoids problems such as end-breaks in fibres. Friction can also cause local fusion of fibres, especially at points where the fibres rub guides and other machine parts during high-speed winding (Lord 2003). The effects of friction on textile fibres are discussed in Gupta (2008). The effects of lubricants in spin finishes on reducing friction are discussed by Kutsenko and Theyson (2008).

## 16.2 Components of spin finishes

Spin finishes consist of several components, including:

- Lubricants
- Emulsifiers
- Antistatic (antistat) agents
- Cohering agents
- Antioxidants
- Pigments
- Antifoam agents
- Other additives (such as bactericides, corrosion inhibitors and wetting agents).

Lubricants are used to enhance the sliding of the fibres against one another during processing and can be hydrocarbon or other mineral oils, vegetable oils, waxes and oils of esters. The latter are particularly popular because they have a lower decrease in viscosity at high temperatures and a high resistance to temperature variations. The selection of lubricant is dependent upon the level of fibre-to-fibre and fibre-to-metal friction during processing. These conditions determine the thermal stability required, which includes factors such as low volatility, good resistance to coagulation, and stability for the period for which the liquid film must remain on a hot surface. In some cases the role of lubricant can be successfully executed by the antistatic agent emulsifier in a spin finish.

Emulsifiers help bind the components in the finish. They also have a lubricating and antistatic effect. To achieve uniform application and penetration of the fibres, the emulsifier must be completely self-dispersible and stable. The emulsifier should also facilitate the complete removal of the finish from fibres for subsequent processing and must not hinder the diffusion of dyes into the fibre during dyeing.

Antistatic agents consist of anionic and cationic emulsifiers, metal salts of fatty acids and ester salts or phosphoric acids. Most antistatic agents have a certain emulsifying effect. Modern spin finishing techniques now include the addition of internal antistats to the polymer melt before extrusion.

Cohering (also known as fibre-adhering) agents promote adherence between fibre strands to prevent hairiness and lapping. Fibre-adhering agents consist of sulphated oils, sarcosides, sulphosuccina and colloidal silicic acid.

Antioxidants (such as steroid-inhibited phenol) give the fibres the ability to resist the formation of insoluble resinous compounds in the presence of oxygen. As a result, they help retain the fibre's original colour and prevent yellowing of the yarns during processing or storage.

The emulsifiers in spin finishes are highly sensitive to bacterial attack. The addition of a bactericide to the spin finish is essential in controlling bacteria during fibre production. An attack by bacteria on the spin finish leads to a breakdown of the emulsifiers in the finish and the formation of gelatinous matter that could cause a blockage of the production lines and poor uniform finish distribution on the fibre or yarns. The application of sodium salts of pyridenethiol oxide, hydroxymethyl amino alcohols, chlorine-formaldehyde releasers or heterocyclic sulphur compositions to a spin finish can make it resistant to bacteria (Fok *et al.* 2006). Spin finishes also contain other additives designed to ensure the stability of fibres to pyrolysis and their retention of tensile strength at high temperatures.

Corrosion inhibitors (such as metal salts of fatty acids and sarcosides) inhibit the development of rust and help prolong the life of machine parts with which fibres come into contact. They also protect fibres from potential discolouration caused by corrosion which produces problems at the dyeing stage.

Spin finish recipes remain some of the best-kept secrets in the manufacturing of synthetic fibres in particular. In general, recipes for spin finishes consist of:

- Up to 81% emulsifiers and antistatic agents
- Around 14% lubricants (with concentration values between 20% and 70%).
- Less than 5% additives.

### 16.3 Types and application of spin finishes

The type of spin finish to be used depends on many factors (Oldrich and Reichstadter 1979, Hawary 2008). These include:

- The chemical properties of the fibres
- The type of spinning process, e.g. short- or long-staple spinning, or continuous filament spinning
- The technique used for applying the finish.

The fibre producer can often give the best advice for selecting the spin finish. It is recommended that the spinning mill applies the fibre manufacturer's own spin finish so that it can be closely matched with the fibre.

Spin finishes are most commonly applied as emulsions, except for acetate finishes which are deposited as pure blended oils. Some finishes are applied by emulsion bath between the drawing stage and the tow going to the top converters as in the case of continuous filament production (Hawary 2008). They can be added all in one go to the polymer solution during spinning as happens in melt spinning. Alternatively, they can be sprayed onto the fibres as in the case of top blending in the gill box frames in the opening and cleaning lines (blow room) during processing of long-staple fibres. In short-staple spinning, spin finishes are sprayed onto the fibres during sandwich blending (wool preparatory stage) and top blending (box drawframe), or onto the roving by droppers or jets. They can be applied by either backwashing or spraying in the wool industry.

The different methods of application of spin finishes are the kiss roller method, the quench chamber system, the finish-meter system and the spray method. The kiss roller method is the most widespread and the oldest technique for finish application. A metallic roller rotates at a constant number of revolutions per minute, and is partially dipped in a basin into which the spin finish solution is fed from an overhead tank. An automated system is used to ensure a constant level of finish in the tank. The spin finish adheres to the kiss roller surface as a film. The filaments of the artificial fibres touch the partially dipped roller at a tangent with a very small central angle of contact. The finish application depends upon spin finish viscosity and wetting properties and on the roller surface speed. The kiss roller method is most suitable for staple fibre yarns and carpet yarns which require relatively high amounts of finish. The disadvantages of the kiss roller system are a certain amount of fluctuation in the distribution of finish on fibres and a higher possibility of bacterial growth since it is a more open system.

In the quench chamber system, oiler pins are located at the lower part of the chamber, just above the air inlet. The finish oil is pumped via a gear pump through the oiler pin which is in contact with the fibre. The spinneret – for continuous filament extrusion – is fixed at the top of the quench chamber, while the winding head is installed at the bottom of the chamber. There are many advantages to the quench chamber system such as better filament cooling between the spinneret and the winding, and a reduction in multifilament tension during winding from 70 cN to 20 cN for a winding linear speed of 3500 metres per minute. This is the optimum tension for building a good polyester bobbin shape and there is more opportunity available for distributing the finish evenly over the filament surface. The quench system is more applicable for high-speed spinning.

The finish-meter method came to be used with the evolution of high-speed spinning systems, where it is capable of accurately applying very small quantities of spin finish with uniformity of distribution along the filament surface. In this system, the yarn guide is fed with the spin finish by means

of a gear pump. A closed control system is used to avoid bacterial growth. The quality of the spin finish application depends on variations in the driving pump's speed, lubricant viscosity and pressure variations of the pump. The finish-meter method is suitable for high-speed spinning of polyester and nylon, friction texturing and fine deniers. There are some disadvantages of the meter-finish system. Major adjustments are required when the number and denier of the filament are changed, and there is also a reduction in filament flexibility (more bending stiffness). For regular distribution of spin finish on a polyester filament yarn in a very short contact time at a high spinning speed, it is recommended that the spin finish is applied at 30 millinewtons per metre (30 mN/m).

In staple fibre spinning, the finish is usually applied after crimping by means of a spray method. The tow is passed under a line of nozzles that spray the finish over the tow at a certain rate. The quality of the applied finish depends on the linear speed of the tow, the number of nozzles, the viscosity of the lubricant, the concentration of the finish and the rate of lubricant flow.

## 16.4 Key requirements for spin finishes

Spin finishes must meet a range of requirements if they are to be effective and to add value to the final product (Klein 1994). These requirements can be classified into three main themes:

- Interaction with fibres
- Interaction with processing conditions and machinery
- Safety and other issues.

It is essential that the application of spin finishes should not affect fibre morphology and quality. A spin finish must be readily adsorbed and have good adherence to the fibre surface. It must have the ability to wet the fibre surface and spread evenly over it to avoid dry friction. On the other hand, it must be easily removed before dyeing (Bernholz *et al.* 1974). It must also have no effects on dyeing absorption, i.e. the dye affinity of fibres, or on dye fastness. Some spin finishes have been used to block certain dyes where this is required (Selivansky *et al.* 1990). It is important to ensure that the finish does not affect the shelf-life of the final yarn. Some finishes use titanium dioxide to enhance colours in fabric but the additive is abrasive and can weaken the yarn (Lord 2003).

Spin finishes must be able to withstand processing conditions. This requires characteristics such as:

- A high resistance to intensive rubbing, i.e. low wearability, and resistance to flaking when subjected to friction

- Thermal stability and reasonable ability to undergo evaporation (sublimation) with no ill-effects
- A constant viscosity with increase in temperature
- Lack of foaming.

Care has to be taken to control the volatility, smoke potential and flashpoint of the finish. These factors are particularly important in texturing where surface temperatures of fibres can reach high levels (Lord 2003). Spin finishes require a minimum flashpoint of at least 110 °C, as determined by the Cleveland Open Cup Method.

Spin finishes must not cause damage to metallic and non-metallic surfaces of machine parts (e.g. aprons, cots of top rollers of the drafting system, rotors in spinning machines). In particular, they must show low migration into polymer (e.g. rubber) components which could cause swelling and fracture. They must not exhibit any gluing effects which might cause fibres to adhere to machinery. They must be easy to clean from both fibres and machinery. Spin finishes using titanium oxide wear guides and it may be necessary to use ceramics at wear points and to avoid frictional content as much as possible in the design of yarn-handling components (Lord 2003).

More generally, spin finishes must be toxicologically and physiologically safe (Mizerovskii 2000). As an example, they must not cause workers inside a spinning mill to get dermatitis. They must also be environmentally friendly, i.e. compatible with environmental regulations and producing no toxic effects, especially when the spin finish is washed from the fibre during finishing. They should ideally be biodegradable and comply with environmental assurance programmes (EAP) (Merino 2008). Typically, at the end of production, synthetic yarns are washed with detergents to remove the spin finish. The resultant waste water contains about 1.3% of lubricant from the spin finish which must be disposed of. Attempts to treat spin finish waste in activated sludge systems have met with serious problems of foaming and low levels of removing toxic chemicals (Gupta and Kothari 1997). The spin finish waste water must usually be isolated from other mill waste streams and treated separately. Some chemists recommend concentrating the spin finish waste by a combination of ultrafiltration or osmosis and evaporation to achieve an oil content that will allow final disposal by incineration. Care must be taken, however, since evaporation of the spin finish waste water to obtain the required oil content can lead to air pollution.

Spin finishes must be capable of being stored for long periods, i.e. have high resistance to ageing, bacterial attacks and oxidation. The autoxidation of spin finish components, from being exposed to air and heat during the processing period, can be observed by yellowing and a change in solubility and viscosity. Finally, spin finishes should be reasonably priced.

## 16.5 Quality issues in the use of spin finishes

The quantity of spin finish applied to the artificial staple fibres of continuous filaments during their processing is also critical and must be optimized so that neither too much nor too little is used. Too little spin finish can also generate technical problems such as increased static electricity charges on the frictional surfaces of the fibres or filaments during processing, and dry surfaces on fibres which lead to surface flakes.

The addition of too much spin finish can lead to a greater amount of smearing, e.g. in the rotor groove (collecting surface) of the rotor spinning machine. In addition to this, it can cause choking in the metallic card cloth and the pins (teeth) of the opening cylinder of the rotor spinning machine. The smearing effect is associated with fibre debris that can generate what is known as hard cake which can cause significant damage to machinery as well as affecting fibre appearance.

It is important that the type and application of spin finish achieves the right balance in the degree of friction achieved during processing. A high fibre-to-fibre friction can lead to efficient binding and cohesion between the fibres in the carding web and in the carded or drawn slivers, lack of excessive bulkiness of the fibrous tufts and the achievement of a reasonable yarn strength. It can also increase the false-twist effect during rotor spinning that helps yarn formation inside the rotor.

A low friction between fibres and machine parts prevents choking of the metallic card cloth, allows easy separation of the fibre wedge from the collecting surface of the rotor's spinning machines, and produces less fibre breakage during carding or opening, and less fibre accumulation in the yarn guides. A low friction between fibres can also result in less fibre disturbance during operations in such operations as roller drafting, the opening line, carding and rotor spinning.

Potential spin finish problems in short-staple plants include:

- Swelling of the rubber aprons and cots of the top rollers of the roller drafting system
- Flaking of fibres and an increase in static charge accumulation, caused by an uneven distribution of spin finish spraying
- The formation of hard coatings on different machine parts such as the teeth of the licker-in, opening roller pins (teeth) of the rotor spinning machines, trumpets on the card, or on the drawframe and the speed frames (flyers) and the pressing arm eyelet; this can lead to an increase in production costs due to the need for more cleaning and more downtime
- A decrease in wear in machine parts such as the sliding wall of the rotor spinning machine's rotors, the traveller of the ring spinning machines, and the toothed cylinders of the feeding section of the rotor spinning machines, due to the fact that the spin finish recipes contain corrosion

inhibitors. Whilst, overall, this is beneficial, it is well known that a degree of wear in machine parts enhances the quality of yarn spinning.

## 16.6 Use of spin finishes on particular types of fibre

The following sections review the use of spin finishes with natural and synthetic fibres.

### 16.6.1 Cotton and wool fibres

The surface of cotton fibres is covered by a 0.3–0.6% layer of natural wax. The role of the wax is to protect and to give elasticity and flexibility to the fibre. When the cotton fibres are processed inside the blow room of a cotton spinning mill, the quantity of natural wax decreases. The addition of a spin to the cotton fibres compensates for this loss. It facilitates the drafting process inside the roller drafting systems of the drawframes, the flyer frames and ring spinning machines. In addition, static charges decrease and the moisture content of the cotton fibres is retained. The number of ends-down decreases on both the speed frame and the ring spinning machine.

The quantity of spin finish required varies from 1 to 8% by mass of the fibre, depending on whether the cotton is being blended with other fibres. The finish can be applied in the first stages of processing either by spraying on the feed lattice of the bale opener or during mixing box formation. It can also be applied during the transport of the fibrous materials via the transport duct (pipe). The moisture content of delivered cotton bales to the spinning mill dictates whether the finish is applied as an oil or as an emulsion. For a normal moisture content of 8–9%, the finish is applied as an oil at a value of 0.2–0.4% of the cotton fibrous material's mass. For a low moisture content (5–6%), it is necessary to use an emulsion quantity of about 2% of the cotton tufts' mass.

A great deal of emulsification is required for processing of wool fibres (Lipenkov 1983). Proper emulsification of the wool fibre blends leads to less fibre breakage during carding as well as low amounts of static electricity, dust and fluff. The quantity of waste produced during carding and spinning is considerably reduced. At the same time, the flexibility, elasticity and cohesion properties of the fibres are improved. The roving produced from the emulsified blend is more uniform and has higher density. In addition, the breakage rate of the roving in the spinning process can be reduced.

The wool fibres are treated with an emulsion. The water contained in the emulsion increases the moisture content of the fibre, improving their flexibility. The emulsion should not contain any free acids that could spoil the needle card cloth of the carding working parts, or alkalis that could impair the wool fibres. The quantity of emulsion used is typically 10–12%

of the total fibre mass. If wool is blended with synthetic fibres, the synthetic fibres are emulsified separately from the wool.

The oily (fatty) materials used in the emulsion include oleic acid (olein), coriander oils and mineral oils. The stability of the emulsion is created by adding different ingredients such as soda ash (0.74%), contact ammonia spirit (0.4–1.1%) and triethanolamine (0.76%). The mixture forms a soap solution which surrounds the fine droplets of fatty materials with a thin film. The fatty droplets cannot join altogether and so remain suspended and uniformly distributed in the total water mass. Depending on the percentage of fatty substances in the emulsion, the quantity used varies for woollen blends from 16 to 31% of the blend mass, and for worsted blends from 5 to 16%.

To minimize static electricity in the production line for wool fibres and their blends with nylon staple fibre, a 4.5% solution of common salt (1.9%) is added to the emulsion. To avoid self-combustion of the mixture, 0.31–0.53% of  $\beta$ -naphthol is added to the olein emulsion. Sometimes, certain types of glue can be added to the emulsion in an amount of 3% to increase the cohesion of the fibres. Some manufacturers provide ready-made pastes which can be mixed with water to create the emulsion.

In the spinning of worsted wool, smaller quantities of lower-concentration emulsions are applied compared with those used for wool spinning. This is true not only for the application of the emulsions before carding but also at subsequent stages (drawing frames for producing combed tops and drawing frames for roving manufacture). Emulsifying at different stages of the worsted yarn production process is required because of the long period of application during which the emulsions dry and their efficacy is lowered.

## 16.6.2 Synthetic fibres

Spin finishes for polyamides use the following ingredients:

- Fixed alkali soap or oleic acid amine
- Sulphated vegetable oil
- Glycol
- White mineral oil
- Butyl stearate.

Phosphate ester is often applied to improve static charge reduction. Polycarbonamide fibres such as nylon are treated with a finish that contains a soft paraffin wax, a hard microcrystalline wax, a salt of a partial phosphate ester, potassium hydroxide and a polyoxyalkylene derivative of a fatty alcohol. The finish is applied by a spray nozzle directed at the yarn bundle on the bulking drum screen.

Polyester fibres typically contain the following ingredients (% of fibre mass):

- Stearamidopropyl dimethyl  $\beta$ -hydroxyethyl ammonium nitrate: 15%
- Polyoxyethylene glycol 200 monolaurate: 25.5%
- *N,N*-di ( $\beta$ -hydroxyethyl) lauramide: 25.5%
- Ployoxyethylene glycol (average molecular mass 600): 34%.

Antioxidants, buffering agents, tinting agents and bactericides are also used. Oxidized polyethylene wax emulsified by morpholine oleate is used for continuous filament Dacron polyester. Finishes for false-twist polyester contain refined coconut oil, a soft hydrocarbon wax and a nonionic emulsifier. Polyolefins use polyethylene oxide-modified fatty oils and ethylene oxide-modified C<sub>12</sub>–C<sub>13</sub> fatty acid primary amines. To minimize swelling of the polyurethane, a polyglycerol ester is used as a nonionic emulsifier.

## 16.7 Use of spin finishes with particular spinning systems

Fibre processing in short-staple spinning requires the addition of a spin finish to the fibres for a number of reasons (Klein 1994). By lubricating the fibre surfaces, the fibres move smoothly against each other and machine parts like the yarn guide, trumpets and aprons. This prevents friction and potential fibre breakage and protects the fibres from the static electricity charges that are generated due to inter-fibre friction, friction between the fibres and machine parts, and the low electrical conductivity of the fibre.

A spin finish can also prevent fibres from splitting from each other, thus leading to less hairiness and less fibre lapping in the final yarn. By promoting greater adherence between fibres, a spin finish can improve the efficiency of bale opening. It can also minimize tuft bulking during tuft blending in the blow room and in the carding process, improving the stability of the carding web and the length of the carded and drawn slivers. By preventing static charges increasing in the wool card, the web is less likely to stick to the doffer comb, and sliver feed is maintained in the balling head.

Fly (airborne fibre particles) can be caused by a lack of cohesion between the fibres themselves and between the fibres and machine parts. In the cotton card, for example, there can be fibre breakage and resulting fly because of the action of the toothed rotating cylinders (taker-in and main cylinder). In ring spinning, the friction between the yarn and the traveller generates fibre fly. In knitting machines, the friction between the yarns and the needles can also lead to the presence of fly. The spin finish increases cohesion between the fibres and the machine parts, reducing fly which otherwise introduces defects into the yarn, requires extra cleaning of machinery and can cause long-term damage to components.

Spin finishes also enhance the binding effect between fibres inside the rotor of the rotor-spinning machines. This helps in yarn formation and its

withdrawal via the doffing tube, and thereby assists package building. Spin finishes eliminate internal fibre-to-fibre friction in the drafting zone of roller drafting systems in draw frames, roving frames and ring-spinning machines. This internal fibre-to-fibre friction during drafting creates drafting waves in the slivers, roving and yarns which create irregularities in the finished yarn.

As has been noted, poor selection and application of a spin finish can cause significant problems. In ring spinning the long periods of exposure of the aprons and top roller covers (cots) to the spin finish can cause swelling of these rubber components and the formation of deposits. Such phenomena are especially noticeable after long periods of operation. In addition, the roller drafting system's aprons often become smeared with spin finish, which causes them to become sticky.

The potential problems caused by an unsuitable spin finish to rotor spinning performance and the yarn produced are much more noticeable than in the case of ring spinning. The fibre-to-fibre cohesion must be low enough to permit the gentle opening of sliver by the opening device without any fibre breakage. On the other hand, the spin finish cohesion must be high enough to allow the fibres to be caught on the opening device's teeth and to be gripped and twisted together on the collecting surface of the rotor.

A low adherence between the fibres and the rotor surface is required so that the yarn can be easily lifted without fibre damage or breakage. On the other hand, a high adherence is required between the navel of the doffing tube and the withdrawn yarn to produce more false twist. If a spin finish does not adhere sufficiently to the fibre surface, it could cause smearing of the finish on all the operating parts such as the opening roller, rotor sliding wall, rotor groove and doffing navel. Deposits on the rotor sliding wall, in the collecting surface of the rotor, and on the navel of the yarn tube also cause poor-quality yarn to be produced. If the right balance is not achieved in the composition of the spin finish, yarn quality is reduced and there is an increased risk of blockage during opening.

In the production of continuous filaments, the use of spin finishes eliminates electrostatic charges building up in filaments inside the tows which can cause filaments to flake and can cause heating and swelling in rubber components in the machinery. Eliminating the build-up of static electricity increases the filament adherence in the tow. This facilitates the building of tow balls or coiling tows into cans. The absence of electrostatic charges and the increase in cohesion between the filaments inside the tows also improve the handling of the continuous filament tows as they are fed to the converters. Spin finishes also prevent oligomers, which can be produced as unwanted by-products during filament processing, being wound on the surface of the filament, damaging its appearance and texture. The use of spin finish oils with wetting agents improves the cohesion of spun polyethylene and ensures

the yarn wraps evenly around the bobbin (Huang and Chen 2006; Textpers Cognis 2001).

## 16.8 Testing spin finishes

The quality of a spin finish has a direct effect on its frictional efficiency. Viscosity and the change of viscosity with temperature (concept of viscosity index) are significant characteristics in the formulation of a finish. Ways of measuring the content of a spin finish are discussed by Acar *et al.* (2006).

The iodine number of the spin finish must be low in order for it to have better ageing stability. The quantity of iodine can be evaluated by chemical analysis. Spin finish viscosity can be measured by devices such as an angular viscometer or a Ferranti viscometer. Measuring the potential volatility of a finish can be undertaken by placing a coated fibre sample in a container, which is then put into a ventilated oven at 200 °C for 2 hours. The loss in spin finish mass per unit exposed area of the container is recorded. The recorded value is the volatility of the tested coating. A good measure of thermal stability is to test a spin finish at 50 °C for 7 days at concentrations of 9–19%. The value of the solid content of the spin finish is determined by evaporating the coating sample at 100–110 °C in an oven for approximately 2 hours. The critical surface tension value of the finish should be less than that of the fibre to obtain a regular distribution and wetting on the fibre surface. The Fisher Auto Tensiomat can measure the finish's surface tension.

Issues in measuring spin finish distribution and uniformity are reviewed by Hild *et al.* (2004). The distribution uniformity of the finish along the length of the fibre or yarn can be determined by sample scanning using ultraviolet (UV) illumination if the finish formulation is visible in a UV light beam. This principle of investigation is used by the M803 tester and the Analog Device tester. Several methods have been developed in the USA for the characterization of the finish distribution along the whole length of the filament. These are:

- The microfluorimetry tracer method
- The scanning of surface wettability technique
- The capacitive sensor system (for on-line measurement of finish distribution).

In the microfluorimetry method, the spin finish is stained with a fluorescent tracer. Ultraviolet excitation and reflectance scanning are used to predict the tracer distribution along the filament length. The surface wettability scanning method has been extremely useful for investigating the distribution of surface finishes on continuous filaments. This method involves preparing a fibre segment with two hooks at its ends. The upper hook is attached to an electronic microbalance, where the drag force exerted by the spin finish

membrane on the fibre can be recorded continuously. The lower hook is attached to a dead weight to apply a given tension to the fibre. As the fibre stretches, a drag force is applied from the spin finish membrane on the moving fibre. The force is recorded by the electronic microbalance, allowing an assessment of finish distribution.

Several techniques are available to measure the spin finish content of fibres (Gupta and Kothari 1997). Some of these are discussed below.

### 16.8.1 Automated infrared (IR) analyser method

A small mass (1 g) of the fibre is put into a container. A known volume of solvent is added. The container is then vibrated to extract the finish. The solvent is transferred to an IR (infrared) cell. The infrared absorbance is recorded at a constant wavelength. The percentage of finish content can be calculated from a specified calibration curve. This manual procedure can be simplified by using an automated IR analyser, where the fibre sample is put on an integrated balance for automatic mass calculation. The extracted finish automatically fills a cup. The finish solution is agitated and pumped to an IR analyser for absorption investigation.

### 16.8.2 Soxhlet technique

A mass of ~10 g of filament/fibre is placed in a funnel. Solvent is added to the mass of fibre and the funnel is vibrated for a few minutes (3–5) to completely remove the spin finish from the yarn. The solvent is then removed via evaporation. The finish content is determined by dividing the mass of the finish by the mass of the sample, and then multiplying by 100. The finish must be completely soluble in the cold solvent. Water is a good solvent for polypropylene while petroleum ether is a suitable solvent for polyamide. The solvent must not solubilize the fibre's oligomers.

### 16.8.3 Near-infrared reflectance analysis (NIRA) technique

This technique is used for measuring the spin finish quantity on the filament/fibre without the use of solvents. When the light beam is blocked by a filament or fibre sample, some of the light beam is absorbed and the rest is reflected. The level of the absorbed light varies according to the chemical nature of the fibre and the finish. Through a comparison of the intensity of the original light and the reflected light, it is possible to determine the percentage of finish quantity on the yarn. A group of standard samples of fibres or filaments with different known percentages of finish are tested by the apparatus to build a correlation between the standard samples and the tested samples.

#### 16.8.4 X-ray photoelectron spectroscopy (XPS) method

X-ray photoelectron spectroscopy (XPS) can be used to give a picture of the morphology of the finish that is deposited on the fibre surface.

#### 16.8.5 Radioactive tracer technique

When the lubricant (finish) is marked with a radioactive tracer, it is then possible to track the finish deposit on the fibre surface with the help of a Geiger counter, or indirectly from contact photography of the filament.

### 16.9 Sources of further information and advice

- Gupta B.S. (ed.), 2008, *Friction in Textiles*, Woodhead Publishing, Cambridge.
- Gupta V.B., Kothari V.K., 1997, *Manufactured Fibre Technology*, Chapman & Hall, London.
- Kutsenko M., Theyson T., 2008, Finishes and treatments to control friction in textile fibres, in B.S. Gupta (ed.), *Friction in Textiles*, Woodhead Publishing, Cambridge.
- Lord P.R., 2003, *Handbook of Yarn Production*, Woodhead Publishing, Cambridge.

### 16.10 Acknowledgement

The author is extremely grateful to all the scientists and researchers mentioned in the references to the chapter for their work in making this chapter possible.

### 16.11 References

- Acar M., Bilgin S., Versteeg H.K., Dani N., Oxenham W., 2006, The mechanism of the air-jet texturing: the role of wetting, spin finish and friction in forming and fixing loops, *Textile Res. J.*, 76(2), 116–125, doi: 1177/0040517506062614
- Behery H.M. and Demir A., 1997, *Synthetic Filament Yarn: Texturing Technology*, Prentice Hall, Upper Saddle River, NJ.
- Bernholz W.F., Redston J.P., Schlatter C., 1974, Spin finish usage and compounding for man-made fibres, *Polymer-Plastics Technology and Engineering*, 3(1), 1-27. doi: 10.1080/03602554085020
- Fok, W.Y., Hild, D.N., Petrick, L.M., Obendorf, S.K., 2006, Autoxidation of spin finishes, *Textile Res. J.*, 76, 616–618. doi: 10.1177/0040517506067674
- Gupta B.S. (ed.), 2008, *Friction in textiles*, Woodhead Publishing Limited, Cambridge
- Gupta V.B. and Kothari V.K., 1997, *Manufactured Fibre Technology*, Chapman & Hall, London.
- Hawary I.A., 2008, Technology of artificial fibres processing, Part I: Short staple processing, Lectures, TED, Alexandria University, Egypt.

- Hild D.N., Obendorf S.K., Fok W.Y., 2004, Mapping of spin finish oils on nylon 66 fibres, *Textile Res. J.*, 74(3), 187–192. doi: 10.1177/004051750407400301
- Huang Y.-P. and Chen T.-K., 2006, Effect of surface treatment on pet spinning and the yarn property, [www.sciencedirect.com](http://www.sciencedirect.com), viewed 23 July 2008.
- Klein W., 1994, *Man-Made Fibres and Their Processing*, Stephen Austin & Sons, Manchester.
- Kutsenko M. and Theyson T., 2008, Finishes and treatments to control friction in textile fibres, in B.S. Gupta (ed.), *Friction in Textiles*, Woodhead Publishing, Cambridge.
- Lipenkov Ya., 1983, *Wool Spinning, Vol. 1, Emulsification of Blends*, Mir Publishers, Moscow, pp. 97–119.
- Lord P.R., 2003, *Handbook of Yarn Production*, Woodhead Publishing, Cambridge.
- Merino, 2008, Environmental Assurance Program (EAP), The Merino Co., Melbourne, Australia.
- Mizerovskii L.N., 2000, Improved spin finish for synthetic fibres: a new approach to solving the problem, *Fibre Chemistry*, 32(3), 221–260.
- Oldrich P., Reichstadter B., 1979, *Processing of Polyester Fibres*, Elsevier, Amsterdam.
- Selivansky D., Walsh W.K., Frushour B.G., 1990, Interactions of spin finishes with partially oriented poly(ethylene terephthalate) fibers: Part 1: The nature of finish/fiber interactions, *Textile Res. J.*, 60, 33–41 doi: 10.1177/004051759006000105
- Slade P.E., 1998, *Handbook of Fiber Finish Technology*, CRC Press, Boca Raton, FL.
- Texpert Cognis, 2001, Textile technology from fibres to finish; Spin finishes: high-performance chemicals for maximum process reliability, July issue, Cognis Deutschland GmbH, Düsseldorf, Germany.

- abrasion resistance, 148–9, 164
- accumulator, 111
- adherence, 426
- advanced fibre information system, 397
- air draft, 82
- air drag, 61–3, 64
- Air-Jet Spinner, 316, 318
- air-jet spinning, 35–7, 151, 416
  - advantages and limitations, 340–1
  - air-jet spun yarns, 326–41
    - applications, 341
    - fasciated structure, 326–31
    - properties, 339–40
  - basic methods, 318–23
    - steps in yarn formation, 319
  - flow-yarn interaction simulation, 337–9
    - kinetic twist predictions, 339
  - future trends, 342
  - Murata methods, 320–3
    - MJS method, 320–1
    - MJS principle, 321
    - MVS method, 322–3
    - MVS principle, 323
  - PLYfil method, 322
    - principle, 322
  - principles, 36
  - swirl flow twisting mechanism
    - principles, 331–7
    - experimental investigation, 331
    - physical modelling, 331–3
  - technology, 366–7
  - textile fibres, 315–42
    - fibre types used, 324–6
  - twisting mechanism basic principles by swirl flow
    - axial velocity profiles, 336
    - numerical simulation, 334–7
    - predicted vs measured values for
      - yarn ballooning, 334
      - tangential velocity profiles, 336
    - yarn ballooning and air pressure
      - frequency relationship, 333
    - yarn ballooning and flow rate
      - frequency relationship, 332
  - wrap fibres separation, 319–20
    - twisting around the core fibres, 320
    - wrap fibre twisting, 320
- air-jet spun yarns, 134–9, 148, 326–41, 366
  - applications, 341
  - end-uses, 139
  - factors influencing properties, 136–9
    - characteristics variations, 140
    - fibre parameters, 136, 138
    - process parameters, 138–9
  - fasciated structure, 326–8
    - classes, 328–30
    - fibre length and wrapping step
      - influence on tenacity, 326
    - fibre types, 326–8
    - illustration of fibre types, 327
    - influence of different classes on
      - yarns strength, 330–1
    - yarn structures classification, 326–7
  - PLYfil single yarn, 329–30
    - class I structure, 329
    - class II structure, 329
    - class III structure, 330
  - plying, 150
  - properties, 136, 339–40
    - fibre profile and spinning speed on
      - performance properties, 137
    - material, 339
    - nozzles geometry, 339
    - process parameters, 339
    - ring and MJS yarns, 340

- structural features, 134–5
  - classification, 134–5
  - migration, 135
  - surface structure, 135
- air-jet technology, 371–4
- air-jet yarns, 194
- air-vortex spinning technology, 374, 416
- AJS *see* Air-Jet Spinner
- AJS 101, 316
- AJS 102, 317
- Amonton's law, 412
- Analogue Device tester, 427
- angular viscometer, 427
- ANN models *see* artificial neural network models
- antioxidants, 418
- antistatic agents, 417
- Apyeil, 290
- aramid, 290
- Arco bridge cradles, 197
- Arenka, 290
- Arkwright's water frame, 14–18
  - basic roller drafting, 15
  - key features on a four spindle machine, 15
  - surface twist angle, 18
  - yarn count system, 18
- artificial neural network models, 338–9
- ATME 1989, 317
- ATME-I 1982, 316
- automated infrared analyser method, 428
- automatic doffing, 209
- automation, 205–9
- autoxidation, 421
  
- back doubling, 83
- bactericide, 418
- bale opener, 108
- bale opening, 108–9
- balloon collapse, 63–4
- balloon length, 59, 61
- ballooning, 338
- batch blending, 111–12
- bead-elastic rod model, 337
- Belmont Roto-twist twist elements, 374
- Belmont textile machinery, 373–4
- bending modulus, 161
- bending rigidity, 149
- bin blending, 111–12
- binding coils, 72
  
- blending
  - carding, 112–15
    - blow-room blended fibres, 116
    - drawframe blended fibres, 117
    - drawframe blending, 114
    - machine, 112–13
    - post-carding blending, 114–15
    - yarn cross-section, 116
  - and composite yarn spinning of textile fibres, 102–18
  - effect of blending methods
    - carding load, 113
    - ring yarn, 115
    - roving, 115
  - fabric creasing
    - wool-acrylic, 104
    - wool-polyester, 103
  - fabric shrinkage
    - wool-acrylic, 104
    - wool-polyester, 103
  - measuring effectiveness, 115–18
    - processing stages and fibre characteristics, 117
  - methods, 108–12
    - bale opener, 108
    - batch blending, 111
    - bin blending unit, 112
    - bin or batch blending, 111–12
    - hopper feeder, 109
    - laydown and bale opening, 108–9
    - sandwich or layer blending, 110
    - unit, 111
    - volume blending, 109–10
    - weigh pan hopper, 110
  - purpose, 102–5
  - staple fibre properties, 104
  - and yarn properties, 105–8
    - blend micronaire, 107
    - fibre distribution, 106
    - fibre fineness, 106–8
    - idealised yarn cross-section, 105
- blending unit, 111
- bouclé yarns, 359
- break draft zone, 402
- break spinning, 26, 80
- Bulgarian Institute of Textiles, 345
  
- cabled yarns, 171
- Capstan equation, 60
- carbon fibres, 290
- carded sliver, 22

- carding, 8, 112–15
  - machine, 112–13
  - post-carding blending, 114–15
- carding drum, 85
- Carpet Research Institute, 359
- centrifugal-jaw twister, 374–5
- chenille method, 349
- cleaning efficiency, 397
- cleaning intensity, 398
- Cleveland Open Cup Method, 421
- closed-circuit cooling system, 205
- coarse opening units, 396
- coefficient of variation, 117
- cohering agents, 418
- cohesion, 426
- coil pitch *see* wrapping pitch
- compact spinning, 215, 233, 406–8
  - advantages and limitations
    - cost saving in raw material, 252
    - improved utilisation of fibre
      - properties, 251–2
  - basic principles, 238
  - compact yarn applications on
    - downstream processing, 253–4
    - dyeing and finishing, 254
    - knitting, 253–4
    - weaving, 253
    - yarn preparation, 253
  - different types of compact system, 242
  - drafting system, 243
  - fibre types used
    - short and long staple spinning, 247–9
    - wool-drafting system cross-section, 248
  - future trends, 254–8
    - conventional two-ply and spin-twisted yarn workflow, 255
    - conventional unidirectional two ply and spin-twisted yarn, 255
    - core compacted yarn, 257
    - plied yarn, 255–8
    - self-cleaning apron in
      - ZinserCompACT, 254
    - self-cleaning apron system, 254
    - Sirospun vs EliTwist plied yarn
      - spinning triangle, 256
    - twist insertion in spin-twisted yarn, 256
  - history, 240–2
  - ring spinning drawbacks, 238–40
  - spinning tension, 240
  - spinning triangle, 239
  - Suessen system, 242–7
    - EliTe system, 245–6
    - fibre path, 247
    - lattice apron in EliTe, 246
    - Rieter K44 ComforSpin, 243–5
    - Rieter K44 ComforSpin compact system, 244, 245
    - Zinser AIR-COM-TEX 700 system, 247
  - textile fibres, 237–58
  - vs ring spinning, 238
  - yarn quality and properties, 249–51
    - conventional vs compact yarn in warping process, 251
    - impact on yarn properties, 249–51
    - quality difference with conventional ring yarn, 250
    - yarn structure, 250
- compact yarns, 76
- complex yarns, 171
- composite yarn spinning, 286–9
  - and blending of textile fibres, 102–18
  - three-component core yarn cross-section, 290
  - two-component friction-spun yarns, 289
    - yarn forming zone, 288
- computer simulation techniques, 359
- continuous filament yarns, 168, 171–2
- Cool Wool, 231
- cop, 12, 50, 71
- cop building, 50, 71
- cop size, 72
- cord yarns, 171
- core fibres, 327, 328, 359
- core-sheath ratio, 144–5, 301
- core-sheath type friction arrangement, 86
- core-spun yarns, 168, 171
- core thread, 350
- core-wild fibres, 327, 328, 330
- core yarns, 209–10
- corrosion inhibitors, 418
- cotton, 218
- cotton carding machine, 21
- cotton fibres, 49, 423–4
- cotton nozzles, 317, 325
- cotton spun yarns, 317
- cotton terry fabrics, 346
- Coulomb's law of friction, 90, 284

- Coverspun method, 346
- cradles, 197
- creel blending, 108
- crepe fabrics, 174–5
- crepe yarns, 174
- Crompton's spinning mule, 19–22
  - illustration, 20
- cycle length, 33
  
- 3D simulations, 319
- Dacron polyester, 425
- Danforth throstle frame, 22
- delivery rollers, 320
- dimensional stability, 156, 162–3
- direct numerical simulation, 334
- distaff system, 6
- DNS method *see* direct numerical simulation
- doffer, 19
- doffing, 12
- double-boss rollers, 53
- double roving spinning system, 210
- doubling, 29, 72
- draft, 130
- drafted sliver, 325
- drafting rollers, 196
- drafting system, 242
- drafting zone, 370
- drain opening, 396
- drape, 163
- drawframe, 21
- drawframe blending, 108, 114
- drawing-in, 283
- drawing passage, 21
- drawing stages, 21
- DREF-1, 274
- DREF-2, 141, 142, 275, 276
  - friction spinning machine, 85, 87, 88, 89
  - schematic diagram, 278
  - yarns, 308
- DREF-3, 141, 144, 275, 276, 278, 296
  - fibre-opening and feeding device, 279
  - friction spinning machine, 86, 87, 88, 89, 93
  - yarns-9, 308
- DREF-5, 275, 276–7, 278
  - friction spinning machine, 86, 87, 89
  - schematic diagram, 279
- DREF-2000, 87, 89, 275, 277, 290
- DREF-3000, 275, 277, 290–1
  
- DREF friction spinning system, 85
- drop spindle, 6
- Du Pont method, 316
- dyeing, 254
  
- EAP *see* environmental assurance programmes
- electrostatic charge, 426
- EliTe CompactSet-L, 245
- EliTe CompactSet-S, 245
- EliTwist, 257–8
- emulsifiers, 417
- end breakage rate, 67
- environmental assurance programmes, 421
- epicyclic driving unit, 369
- extent of fibre damage, 399
  
- false-twist effect, 422
- false-twist principle, 32
- false twister, 347
- false twisting, 33
- fancy yarns, 171, 349–53
  - spinning, 349–51
    - bouclé yarns fasciated structure, 351
    - different type of effect yarns, 350
    - structures, 352–3
    - wrap-spun applications, 358–9
- fasciated spinning, 316
- fasciated yarn *see* air-jet spun yarns
- fasciated yarn spinning, 35
- Fearnought machine, 112
- Fehrer's DrefRing development, 241
- Ferranti viscometer, 427
- fibre, 391, 414
  - types and their classification, 156
- fibre adhering agents *see* cohering agents
- fibre belts, 84
- fibre breakage, 392, 393–402, 414
  - areas of potential breakage during spinning preparation, 394
  - cleaning efficiency concept, 398
  - fibre fragmentation extent, 401
  - possibilities of change in short fibre content upon cleaning, 400
  - short fibre conservation rule, 401
  - stepwise opening concept, 396
- fibre cohesion, 392
- fibre consolidation, 48–9
- fibre damage
  - caused by spinning, 390–414

- definition, 390, 412
- fibre breakage, 393–402
- forms, 392–3
- friction spinning, 409, 411–12
  - rotor vs friction spinning fibre landing, 411
  - twisting principle, 413
- ring and compact spinning, 402–8
  - compact spinning, 407
  - forces applied to fibres, 403
  - spindle speed effect on spinning tension, 405
- rotor spinning, 408–9
  - principle, 410
- textile fibre characteristics and processing, 391–3
- what can be considered fibre damage, 392
- yarn-forming process, 402
- fibre density, 166, 378
- fibre disorientation, 412
- fibre elongation at break, 117
- fibre fineness, 106–8, 166
- fibre fragmentation, 398–9
- fibre length, 138, 305, 368
- fibre looping, 412
- fibre migration, 120–2, 126–7, 176, 180, 238–40, 404
  - influencing factors, 176–7
  - mechanisms, 176
- fibre neps, 412
- fibre reflectance, 117
- fibre slippage, 67
- fibre tenacity, 117
- fibre transfer, 265–9
- filament wrapping, 37–9
  - hollow-spindle spinning, 37–9
    - basic principle, 38
  - selfil spinning, 37
- fine openers, 396
- finish-meter system, 419–20
- finishing, 254
- Fisher Auto Tensiomat, 427
- flame-resistant fibre, 290
- flexibility, 391–2
- fluted takeoff nozzle, 269
- four-spindle belt drive, 202
- free fibre spinning, 80
- friction, 166
- friction spinning, 29, 35, 84–93, 274–310
  - advantages and limitations, 306–8
  - application of friction-spun yarns, 308–9
    - DREF 2 yarns, 308
    - DREF 3 yarns, 309
  - composite yarn spinning, 286–9
    - three-component core yarn cross-section, 290
    - two-component friction-spun yarns, 289
    - yarn forming zone, 288
  - definition and background, 274–5
  - DREF-2 friction-spinning machine, 276
  - DREF-3 friction-spinning machine, 277
  - DREF-3 spinning system, 86
  - fibre processing, 87–92
    - fibre opening and DREF-III feeding device, 89
    - fibre sleeve and yarn formation mode, 91
    - theoretical torque distribution, 91
    - yarn cross-section, 90
  - friction spun yarn
    - fibre extent at various suction air pressures, 294
    - filament false-twist in core yarn friction spinning, 295
    - histogram of fibre extent, 293
    - various production speeds, 293
    - various suction air pressures, 292
  - friction spun yarn structure and properties, 291–306
    - in comparison with other spinning systems, 305–6
    - post-spinning process and yarn properties, 305
    - yarn structure, 291–5
  - friction yarns structures vs other yarn types, 92–3
  - future trends, 309–10
  - illustration, 31, 85
  - operation principle, 275–7
  - spinning performance and yarn properties, 295–305
    - effect of friction roller speed, 299
    - fibre extent histogram, 297
    - fibre parameters and yarn properties, 303–5
    - machine parameters and yarn properties, 295–7
    - process parameters and yarn properties, 297–303

- spinning speed effect on breaking strength, 300
- twist efficiency of various yarn counts, 302
- suction air pressure
  - effect on twist efficiency, 301
  - effect on yarn strength, 300
- types of fibres used, 289–91
- yarn formation on machines, 277–85
  - developed fibre transport devices, 281
  - fibre accumulation methods, 282
  - fibre feeding device, 277–8
  - fibre transport device, 278–83
  - forces acting on yarn, 285
  - torque distribution along the yarn tail, 287
  - tracer fibre, 282
  - twisting device, 283–5
  - yarn tail during OE friction spinning, 287
- yarn tension
  - and forces acting on yarn, 286
  - and suction air pressure, 304
  - and yarn diameter, 303
- friction spun yarns, 87, 92, 93, 141–6, 148
  - end uses, 146
  - factors affecting yarn properties, 143–6
    - fibre factors, 145–6
    - machine parameters, 143–4
    - polyester DREF-3 yarns structural and mechanical parameters, 146
    - process parameters, 144–5
  - fibre extent at various suction air pressures, 294
  - filament false-twist in core yarn friction spinning, 295
  - histogram of fibre extent, 293
  - plying, 150
  - properties, 143
  - structural features, 141–2
    - DREF-2 surface structure, 141
    - migration, 141–2
    - surface structure, 141
    - twist structure, 142
  - yarn formation on DREF-2 friction spinner, 142
  - structure and properties
    - in comparison with other spinning systems, 305–6
    - post-spinning process and yarn properties, 305
    - yarn structure, 291–5
    - various production speeds, 293
    - various suction air pressures, 292
- friction-spun yarns
  - structure and properties, 291–306
- friction twisting, 84
- front rollers, 321
- G-35 ring spinning machines, 53
- G-groove rotor, 267–8
- garnet wire, 87
- GB patent 1341918, 372
- Geiger counter, 429
- Goetzfried method, 315, 316, 320
- 802H system, 317, 318
- hairiness, 124, 125
- hand spinning, 4–6
  - drop spindle and distaff system, 6
  - early hand spinning technique, 5
- hard cake, 422
- hard coverings, 54
- Hargreaves' spinning jenny, 9–12
  - illustration, 10
  - operation, 11
- heck, 13
- Henshaw's model, 384
- high performance fibres, 155
- HiLoft terry fabrics, 346
- hollow spindle device, 345
- hollow spindle spinning, 367
  - advantages and limitations, 359–61
  - basic principle, 38, 346–52
    - bouclé yarns fasciated structure, 351
    - different type of effect yarns, 350
    - fancy yarns spinning, 349–51
    - general remarks, 346–9
    - illustration, 347
    - methods, 349
    - wrap yarns made by hollow spindle machine, 351
    - wrap yarns spinning, 351–2
  - process, 37
  - spun yarns applications, 358–9
    - modern spinning methods, 360
  - textile fibres, 345–61
  - wrap yarns quality assessment, 355–8
    - breaking mechanism, 356
    - mechanical properties, 355–6

- wrap yarns vs twofold ring spun yarns, 356–8
    - breaking elongation, 358
    - tenacity, 357
    - twist liveliness, 357
  - yarn structures, 352–4
    - fancy yarn structures, 352–3
    - wrap yarn structures, 353–4
  - hopper feeder, 109
  - hosiery, 174
  - hot-wire anemometer, 331
  - hybrid yarns, 353
  
  - IBI *see* index of blend irregularity
  - ideal unevenness, 123
  - in-phase self-twist yarn, 370
  - inclined fibre feed, 89
  - index of blend irregularity, 106
  - industrialised spinning systems, 17
  - initial modulus, 160, 161
  - intermediate openers, 396
  - intimate blending, 108
  - iodine number, 427
  
  - jet-ring spinning, 212–15
  
  - k – e** turbulence method, 335
  - Karvin, 290
  - Kermel, 290
  - Kevlar, 290
  - kinetic twist, 338
  - kiss roller method, 419
  - knitted fabrics
    - fibre properties affecting knitted goods, 158–61
      - cross-section shapes and fibre contours, 159
    - fibre load-elongation curve, 160
    - initial modulus, 161
    - mechanical properties, 158–61
    - physical properties, 158
    - raw material, 158
    - stress-strains curves of fibres, 162
    - stress-strains curves of fibres tested, 162
  - principal requirements for ends uses, 156–61
  - properties, 156, 158
  - yarn structural requirements, 155–81
- knitting, 253–4
- knurled flutes, 53
- 
- Konex, 290
- 
- Laser-Doppler Anemometry, 319, 331, 332
- layer blending, 110
- LDA *see* Laser-Doppler Anemometry
- Leesana concept, 346
- Lewis Paul's concept, 23
- lint cleaning, 395
- long-fibre wheel, 12
- long-staple Sirospun, 219–24
- long staple spinning, 247–9
- lubricants, 417
- Lycra, 228
- 
- M803 tester, 427
- Macart spinning system S300 ST, 371
- Mackie Spinmack hallow spindle machine, 361
- magnetic spinning, 197–8
- main cylinder, 21
- Marzoli MP1-N, 200
- Marzoli MPT-N, 200, 201
- Marzoli ring spinning machine, 196
- mass conservation law, 399
- Masterspinner, 274, 275–6
- Max number, 332
- mechanical-aerodynamic spinning, 85
- mechanical draft, 82
- mechanical twisting, 83
- Mechanism I, 356
- medical textiles, 165
- MEMO, 208
- Merlin, 211
- microfluorimetry method, 427
- micronaire, 107, 108, 117
- MJS *see* Murata Jet Spinner
- MJS 801 machine, 316
- MJS 802 machine, 317, 325
- MJS 802H machine, 324
- MJS 802HR machine, 325
- modified Rieter ring-spinning machine, 241
- moisture, 166
- monofilament, 358
- MTS *see* Murata Twin Spinner
- MTS-81, 317
- mule spinning process, 19
- mules, 19
- multifold yarns, 169–71
- multiple-sliver feed system, 87
- Murata Jet Spinner, 316, 318, 320

- Murata Twin Spinner, 225, 317, 320  
 Murata Vortex Spinner, 93, 318, 320, 322, 341  
 MVS 61 machine, 318
- Navier-Stokes equations, 334  
 near-infrared reflectance analysis  
   technique, 428  
 needle pin-clothed opening rollers, 87  
 nep removal efficiency, 399  
 Nomex, 290  
 novelty yarns, 171  
 nozzle pressure, 95  
 nozzle ring spinning, 212–15  
 NV air twist system, 373
- OE spinning *see* open end spinning  
 oligomers, 426  
 on-axis twisting, 5  
 open-end friction yarns, 194  
 open-end/rotor spinning, 366  
 open end spinning  
   friction spinning, 84–93  
     DREF-3 spinning system, 86  
     fibre opening and DREF-3 feeding device, 89  
     fibre processing, 87–92  
     fibre sleeve and yarn formation mode, 91  
     friction yarns structures vs other yarn types, 92–3  
     illustration, 85  
     theoretical torque distribution, 91  
     yarn cross-section, 90  
   fundamental principles for textiles fibres, 79–98  
   method, 26–9  
     friction spinning, 29  
     illustration of friction spinning, 31  
     principles, 27  
     rotor spinning, 27–9  
   process flow chart, 80  
   rotor spinning, 81–4  
     fibre processing, 83–4  
     general principle, 82  
   vortex spinning, 93–7  
     feed material passage, 94  
     fibre edges expansion, 94  
     ring yarn cross-section, 96  
     ring yarn structure micrograph, 96  
     rotor yarn cross-section, 96  
     rotor yarn structure micrograph, 96  
     structure compared to other yarn types, 93–7  
     twist distribution difference, 97  
     vortex yarn cross-section, 95  
     vortex yarn structure micrograph, 95  
     yarn characteristics comparison, 97  
 open end yarns, 81  
 opening roller, 80, 85, 130, 143, 264  
 3-over-3 drafting system, 14  
 over-stretching, 393, 414
- pairing twist, 385  
 PAM-150 method, 316  
 Paradisc, 88, 280  
 Parafil 2000, 346  
 Parafil 1000K, 346  
 Parafil 1000S, 346  
 parallel yarn *see* wrap yarns  
 Parallelisator, 88, 280  
 percent short fibre content, 399  
 peroxidised fibre, 290  
 PF-1 method, 316  
 phased self-twist yarn, 370  
 phasing, 369–71, 382  
 phosphate ester, 424  
 PLA fibres, 74  
 plied yarns, 149, 169–71, 255–8  
 ply-twisting, 73  
 PLYfil 2000, 225  
 PLYfil method, 317, 320, 322, 325  
 plying, 29, 72  
 point-to-point action, 8  
 polycarbonamide fibres, 424  
 polyester fibres, 424–5  
 polyfilament, 358  
 polyglycerol ester, 425  
 polyimide, 290  
 polyurethane, 425  
 post-carding blending, 114–15  
 post-spinning, 72–4  
   ply twisting, 73–4  
     ring twisting machine, 74  
     two-for-one twisting mechanism, 75  
   yarn rewinding and fault clearing, 73  
 Prandtl tube, 331  
 Prenomit hollow spindle machine, 353, 358  
 Prenomit ON-1, 351  
 Prenomit technologies, 346  
 production speed, 138

- PSL Masterspinner, 87, 89
- quench chamber system, 419
- radial injectors, 322
- radioactive tracer technique, 429
- real twist, 217
- Repeco self-twist machine, 369, 371, 380
- Repeco spinning system, 34, 37
- reserve-winding, 204–5
- revolving flat cards, 21
- Reynolds number, 332
- Ri-Q bridge cradles, 197
- Rieter G35 Flexi start, 200
- Rieter K44 ComforSpin, 243–5
- ring
  - and traveller, 198–200
  - types, 199
- ring spinning, 193–4, 217–19, 365
  - advantages and limitations, 194–5
  - applications, 74–6
    - short and long-staple fibres, 76
  - basic principles, 43–4
    - fibre assembly in ring spinning, 43
    - twist insertion, 43–4
  - developments, 195–216
    - bottom apron deflection, 197
    - closed-circuit cooling system, 205
    - core yarns production technologies, 209–10
    - double roving ring spinning machine, 213
    - double roving spinning system, 210
    - drafting arrangement modification, 197
    - drafting rollers delayed start-up, 196
    - drive systems, 200
    - elastic core attachment, 211
    - four-spindle belt drive, 202
    - hard core filament attachment, 212
    - machine with multiple spinning systems, 210–11
    - new drive system, 201
    - reserve-winding elimination, 204–5
    - ring and traveller, 198–200
    - ring and traveller types, 199
    - rotating ring, 197–8
    - roving guide drive, 196
    - roving guides, 196
    - SERVO grip, 204
    - Servo motor drives for drafting system, 203
    - spindle drives, 200–2
    - tangential spindle drive, 202
    - timing belt, 203
    - top apron extending into the back zone, 198
    - traveller cross-sections, 199
  - drafting arrangement inclination, 55–6
    - inclinations and spinning triangle sizes, 56
  - drawbacks, 238–40
  - fundamental principles for textile fibres, 42–77
  - future trends, 76–7, 216
  - low hairiness yarns production technologies, 211–16
    - airflow in Z- and S-nozzles, 214
    - drag forces acting on a hair, 215
    - hairiness values of ring and nozzle-ring cotton yarns, 215
    - nozzle assembly, 214
    - nozzle ring spinning, 212–15
    - systems with modified spinning triangle, 215–16
  - machines automation, 205–9
    - automatic cop transport to winding, 209
    - automatic doffing, 209
    - automatic roving bobbin transfer, 206
    - automatic transfer of roving bobbin with rows of creel, 206
    - Marzoli's roving stop motion, 208
    - monitoring, 207–8
    - roving bobbin transfer, 205
    - roving bobbin transfer from roving machine to creel, 205–7
    - roving stop motion, 207
    - spinning parameters and data retrieval centralised control, 208–9
  - main technologies of spinning, 194
  - major staple fibre spinning systems, 195
  - method, 22–5
    - ring and traveller system key features, 24
    - yarn path, 23
  - process description, 49–72
    - package formation and sizes, 71–2

- ring spinning machine, 50
- ring and traveller, 56–8
  - combinations, 57
  - travellers cross-section, 57
- roller drafting, 51–5
  - double apron drafting system, 51
  - force change, 52
  - hardness values, 53
  - tangential components, 55
  - top roller offset over bottom roller, 54–5
  - top rollers, 53–4
- spinning tension variation, 64–71
  - damped ring rail traverse, 66
  - end breakage mechanism, 68–71
  - fibre bundles strength distribution, 69
  - fluctuations in milliseconds, 66
  - ring rail traverse, 65
  - and ring spinning end breaks, 67–71
  - variation from beginning to cop end, 64
  - yarn breakage rate and spinning speed control, 71
  - yarn wrap angle, 67
- spinning triangle and fibre consolidation, 48–9
- systems, 49
- textile fibres, 193–216
- vs compact spinning, 238
  - spinning tension, 240
  - spinning triangle, 239
- yarn formation, 47
- yarn tensions and balloon geometry, 58–64
  - air drag, 61–3
  - balloon collapse, 63–4
  - balloon control ring, 63
  - balloon with neck formation, 63
  - circularly polarised standing wave, 59
  - forces acting on traveller, 61
- ring spinning frame, 22
- ring spun yarns, 81, 115, 120–6, 148, 151
  - end uses, 125–6
  - factors affecting yarn properties, 124–5
    - fibre factors, 124–5
    - machine factors, 125
    - yarn factors, 125
  - plying, 149
  - properties, 123–4
    - hairiness, 124
    - mass irregularity and imperfections, 123–4
    - tensile properties, 123
    - structural features, 120–2
      - migration, 120–2
      - migration parameters in a spun rayon yarn, 122
      - surface structure, 121
      - tracer fibre path, 122
- ring-traveller system, 404
- 804 RJS, 317–18, 318
- roller-and-clear card, 21
- roller drafting, 22, 51–5
  - double apron drafting system, 51
  - force change, 52
  - top roller offset over bottom roller, 54–5
    - tangential components, 55
  - top rollers, 53–4
    - hardness values, 53
- 3-pair roller drafting system, 14
- rotating ring, 197–8
- Rothschild tensiometer-2000, 70
- rotor, 266–8
  - groove, 267–8
  - speed and diameter, 266–7
  - wall, 268
- rotor diameter, 130
- rotor loop fancy yarns, 353
- rotor spinning, 27–9, 81–4, 261–2
  - basic features, 28
  - factors affecting spinning stability, 271
  - fibre processing, 83–4
  - fibre transfer, 265–9
    - rotor, 266–8
    - rotor grooves, 268
    - takeoff nozzle, 268–9
  - general principle, 82
  - key features and operating principles, 262–5
    - main features, 262
    - opening methods, 264–5
    - sliver preparation, 263–4
- modern machines, 269–70
- rotor spun yarns structure and properties, 271–2
- synthetic fibres and blends, 131–4
  - choice of raw material, 131–2
  - choice of rotor machine variables, 133–4

- sliver requirements, 132–3
  - textile fibres, 261–73
  - yarn breakage, 270–1
  - yarn formation, 30
- rotor spun yarns, 92, 126–34, 148, 194
  - end uses of rotor spun yarns, 134
  - factors affecting yarn properties, 128–30
    - changes in doffing tube parameters, 131
    - fibre parameters, 128–9
    - measured yarn properties, 131
    - rotor machine variables, 130
    - sliver quality, 129
  - plying, 149–50
  - properties, 128
  - structural features, 126–8
    - migration, 126–7
    - surface structure, 126
    - surface structure micrographs, 127
    - surface structure representation, 126
    - twist deviation, 128
  - structure and properties, 271–2
  - synthetic fibres and blends, 131–4
    - choice of raw material, 131–2
    - choice of rotor machine variables, 133–4
    - sliver requirements, 132–3
- roving, 9, 115
- roving guide, 196
- running-in, 200
- S-groove rotor, 268
- sandwich blending, 110
- SAW *see* SpinAssemblyWinding
- SAWTRI technology, 360
- Saxon wheel, 12–14
  - spinning actions, 13
- scouring, 21
- self-acting mule, 19
- self-pumping effect, 84, 409
- self-twist spinning, 219
  - air-jet spun yarn, 367
  - fabric appearance
    - relaxation and knit structure effect, 387
    - twist level and knit structure effect, 386
  - factors affecting strand twist, 376–81
    - fibre denier on ST twist yarn, 380
    - nip gap on yarn twist per half-cycle, 377
    - production speed on strand twist, 377
    - production speed on winding-on tension, 379
    - ST roller on nip gap, 377
    - tension variation on twist per half-cycle, 379
    - tension variation on yarn tenacity, 379
    - top twisting roller load on twist per half-cycle, 381
    - twist before and after convergence guide, 378
    - winding tension adjustment, 378
    - wool fibre denier on ST twist yarn, 380
- method, 29, 32–4
  - false twist principle, 32
  - in-phase and 180° phased ST yarn structures, 35
  - principle, 34
- OE friction spun yarn, 366
- OE rotor spun yarn, 366
- principles, 368–9
- technology, 369–75
  - air-jet technology, 371–4
  - Belmont Roto-twist twist elements, 374
  - centrifugal-jaw twister, 375
  - continuous filaments self-twist spinning machine, 375
  - NV-Gilbos self-twist yarn, 373
  - NV-Gilbos self-twisting device, 373
  - other variations, 374–5
  - self-twist machine principle, 370
  - tandem air-jet self-twist device, 372
  - tube twister, 376
  - twist distribution in self-twist yarn, 370
  - WinSpin self-twist machine principle, 371
- textile fibres, 365–87
- vortex spun yarn, 367
- wrap spun yarn, 367
- yarn strength and stability, 381–7
  - in-phase and phased yarn, 382
  - phasing angle on tenacity, 382
  - phasing angle on twist per half-cycle, 383

- self-twist twisted yarn or twofold
  - unidirectional twisted yarn, 385
- self-twist yarn cross-sectional model
  - courtesy, 383
- self-twist yarns, 34
- selfl spinning, 37
- Servogrip, 204
- shearability, 163
- shearing, 163
- short-staple Sirospun, 224–5
- short staple spinning, 247–9
- single yarns, 168–9
- siro spinning
  - advantages and limitations, 229–31
  - ancillary processes development, 232–3
  - applications, 231–2
  - future trends, 233–4
  - Sirospun, 219–25
    - alternatives, 225
    - breakout device, 222
    - components, 223
    - long-staple, 219–24
    - model yarn, 221
    - short-staple, 224–5
    - two-strand spinning system, 220
  - Solospun, 225–7
    - mini-strands production, 226
    - slotted roller pair clipped beneath front rollers, 226
  - textile fibres, 217–34
  - types of fibres used, 227–8
  - yarn quality and properties achieved, 228–9
- Siro spinning process, 367
- Siroclear, 233
- sirofil, 228
- Sirospun, 219–25, 357
  - alternatives, 225
  - breakout device, 222
  - components, 223
  - long-staple, 219–24
  - model yarn, 221
  - short-staple, 224–5
- slenderness ratio, 391
- slippage effect, 412
- sliver orientation index, 402
- slubbing, 22
- smart fibres, 165
- smart textiles, 165
- smooth takeoff nozzle, 269
- soft coverings, 54
- SOI *see* sliver orientation index
- solo spinning, 215–16
- Solospun, 225–7, 357
  - mini-strands production, 226
  - slotted roller pair clipped beneath front rollers, 226
- Soxhlet technique, 428
- spin finish waste water, 421
- spin finishes, 416–29
  - components, 417–18
  - function, 416–17
  - key requirements, 420–1
  - potential problems, 422–3
  - quality issues in their use, 422–3
  - testing methods, 427–9
    - automated infrared analyser method, 428
    - near-infrared reflectance analysis technique, 428
    - radioactive tracer technique, 429
    - Soxhlet technique, 428
    - X-ray photoelectron spectroscopy method, 429
  - types and application, 418–20
  - use on particular types of fibre, 423–5
    - cotton and wool fibres, 423–4
    - synthetic fibres, 424–5
  - use with particular spinning systems, 425–7
- SpinAssemblyWinding, 317
- spindle drafting, 10, 19
- spindle drives, 200–2
- Spinmack machine, 348
- spinning frame, 14
- spinning geometry, 238
- spinning nozzles, 317, 322
- spinning speed, 25
- spinning technology
  - developments overview, 3–40
  - early developments, 9–22
    - Arkwright's water frame, 14–18
    - Crompton's spinning mule, 19–22
    - Hargreaves' spinning jenny, 9–12
    - Saxon wheel, 12–14
  - early history, 4–9
    - hand spinning, 4–6
    - the spinning wheel, 6–9
  - modern spinning methods and developments, 25–6
  - ring spinning, 22–5

- ring and traveller system key features, 24
- yarn path, 23
- spinning techniques classification, 39
- twist spinning methods, 26–34
  - open-end spinning method, 26–9
  - self-twist spinning method, 29, 32–4
- warp spinning methods, 34–9
  - filament wrapping, 37–9
  - surface fibre wrapping, 34–7
- spinning tension, 64–71, 145, 240, 302, 404
- ring spinning end breaks
  - fibre bundles strength distribution, 69
  - mechanism, 68–71
  - yarn breakage rate and spinning speed control, 71
  - and ring spinning end breaks, 67–71
- spinning triangle, 48, 238–40, 404
- spinning wheel, 6–9
  - cottage hand carding and spinning, 8
  - hand carding actions, 9
  - illustration, 7
- spiral takeoff nozzle, 269
- spray method, 420
- ST-yarns *see* self-twist yarns
- staple fibre spinning, 4, 150–1, 420
- staple fibre yarns, 167–8
  - plying, 149–50
    - air-jet spun yarns, 150
    - friction spun yarns, 150
    - ring spun yarns, 149
    - rotor spun yarns, 149–50
- staple spun yarns
  - structure-property relationships, 147–9
    - abrasion resistance, 148–9
    - bending rigidity, 149
    - breaking elongation, 148
    - tenacity, 147–8
- strand twist, 222
- suction air pressure, 144, 298
- Suessen EliTe, 245–6
  - drafting system, 243
  - lattice apron, 246
  - wool-drafting system cross-section, 248
- surface alteration, 393, 414
- surface fibre wrapping, 34–7
  - air-jet spinning, 35–7
    - principles, 36
  - friction spinning, 35
- surface wettability scanning method, 427
- swift, 21
- swirl flow modelling, 331–7
  - experimental investigation, 331
  - flow-yarn interaction, 337–9
    - kinetic twist predictions, 339
  - numerical simulation, 334–7
    - axial velocity profiles, 336
    - tangential velocity profiles, 336
  - physical modelling, 331–3
    - air pressure values, 333
    - predicted vs measured values for yarn ballooning, 334
  - yarn ballooning
    - and air pressure frequency relationship, 333
    - and flow rate frequency relationship, 332
- swirl takeoff nozzle, 269
- synthetic fibres, 424–5
- takeoff nozzle, 268–9
- tandem air jets, 372
- tangential spindle drive, 201–2
- tenacity, 147–8
- tensile modulus, 161
- tension migration, 49
- textile fibres
  - air-jet spinning, 315–42
    - advantages and limitations, 340–1
    - air-jet spun yarn properties, 339–40
    - air-jet spun yarns fasciated structure, 326–31
    - applications, 341
    - basic air-jet spinning methods, 318–23
    - fibres types used, 324–6
    - flow-yarn interaction simulation, 337–9
    - future trends, 342
    - swirl flow twisting mechanism basic principles, 331–7
  - blending and composite yarn spinning, 102–18
    - blending and yarn properties, 105–8
    - blending methods, 108–12
    - carding, 112–15
    - measuring the effectiveness of blending, 115–18
    - purpose of blending, 102–5
    - characteristics and processing, 391–3

- classification, 157
- compact spinning, 237–58
  - advantages and limitations, 251–2
  - applications on downstream processing, 253–4
  - basic principles, 238
  - fibre types used, 247–51
  - future trends, 254–8
  - history, 240–2
  - ring spinning drawbacks, 238–40
  - Suessen system, 242–7
  - vs ring spinning, 238
  - yarn quality and properties, 249–51
- friction spinning, 274–310
  - advantages and limitations, 306–8
  - application of friction-spun yarns, 308–9
  - composite yarn spinning, 286–9
  - friction-spun yarn structure and properties, 291–306
  - future trends, 309–10
  - types of fibres used, 289–91
  - yarn formation, 277–85
- hollow spindle spinning, 345–61
  - advantages and limitations, 359–61
  - basic principle, 346–52
  - future trends, 361
  - spun yarn structures, 352–4
  - spun yarns application, 358–9
  - wrap yarns quality assessment, 355–8
- open end spinning fundamental
  - principles, 79–98
  - flow chart, 80
  - friction spinning, 84–93
  - rotor spinning, 81–4
  - vortex spinning, 93–7
- ring spinning, 42–77, 193–216
  - advantages and limitations, 194–5
  - applications, 74–6
  - developments, 195–216
  - future trends, 76–7, 216
  - main technologies of spinning, 194
  - post-spinning, 72–4
  - process description, 49–72
  - ring spinning, 44, 46–9
  - ring spinning systems, 49
  - spinning basic principles, 43–4
- rotor spinning, 261–73
  - fibre transfer, 265–9
  - key features and operating principles, 262–5
  - modern machines, 269–70
  - performance, 270–1
  - rotor spun yarns structure and properties, 271–2
- self-twist spinning, 365–87
  - factors affecting strand twist, 376–81
  - principles, 368–9
  - technology, 369–75
  - yarn strength and stability, 381–7
- siro spinning, 217–34
  - advantages and limitations, 229–31
  - ancillary processes development, 232–3
  - applications, 231–2
  - future trends, 233–4
  - Sirospun, 219–25
  - Solospun, 225–7
  - types of fibres used, 227–8
  - yarn quality and properties achieved, 228–9
- spinning technology developments
  - overview, 3–40
  - early developments, 9–22
  - early history, 4–9
  - modern spinning methods and developments, 25–6
  - ring spinning, 22–5
  - twist spinning methods, 26–34
  - wrap spinning methods, 34–9
  - textile spin finishes, 416–29
- Thermosplicer, 224, 230, 232
- timing belt, 203
- TJS *see* Toyoda Jet Spinner
- Toray method, 320
- torsional modulus, 161
- total draft, 83
- total mechanical draft, 83
- Toyoda Jet Spinner, 316
- tracer fibre technique, 280
- traveller, 24, 194
  - cross-sections, 199
  - and ring, 198–200
  - types, 199
- tube twister, 375
  - schematic diagram, 376
- Twinsplicer, 232
- twist angle, 385
- twist insertion, 43–4
  - false twist, 44

- principles, 46
  - mechanism, 79
  - real twist, 44
    - principles, 45
- twisting-out, 44
- twisting point, 46
- two-for-one twister, 74
- two-strand spinning system, 220, 225
  
- U-groove rotor, 268
- UHM *see* upper half mean length
- ultraviolet illumination, 427
- upper half mean length, 117
- Uster Evenness Tester, 301
- Uster Technologies, 397
  
- vertical feed, 89
- voile, 174
- volume blending, 109–10
- vortex spinning, 93–7
  - feed material passage, 94
  - fibre edges expansion, 94
  - structure compared to other yarn types, 93–7
    - ring yarn cross-section, 96
    - ring yarn structure micrograph, 96
    - rotor yarn cross-section, 96
    - rotor yarn structure micrograph, 96
    - twist distribution difference, 97
    - vortex yarn cross-section, 95
    - vortex yarn structure micrograph, 95
    - yarn characteristics comparison, 97
  
- water frame, 14
- weak zones, 412
- weaving, 253
- weigh pan feeders, 110
- weigh pan hopper, 110
- whorl, 5
- wild fibres, 327
- winding coils, 72
- WinSpin Machine, 369, 371
- wool, 5, 218
- wool fibres, 49, 423–4
- woollen spinning, 22
- woollen yarns, 360–1
- worsted system, 366
- wound bobbin, 71
- woven fabrics
  - fibre properties affecting woven goods, 164–6
  - mechanical properties, 166
  - physical properties, 165–6
  - raw material, 164–5
- principal requirements for end uses, 161–6
- properties, 161–4
  - abrasion resistance, 164
  - dimensional stability, 162–3
  - drape and shearability, 163
  - durability, 163
  - tearing strength, 163–4
  - tensile properties, 164
- yarn structural requirements, 155–81
- wrap fibres, 327, 328
- wrap spinning, 120
- wrap-spun fancy yarns, 358
- wrap spun yarns, 146–7
  - end uses, 147
  - factors affecting characteristics, 147
  - properties, 146
    - surface structure, 147
- wrap thread, 353
- wrap-wild fibres, 327, 328, 330
- wrap yarns, 351–8, 366
  - quality assessment, 355–8
    - breaking mechanism, 356
    - mechanical properties, 355–6
    - vs twofold ring yarns, 356–8
  - spinning, 351–2
    - wrap yarns made by hollow spindle machine, 351
  - structures, 353–4
    - wrapping pitch, 354
    - yarn structure under microscope, 354
  - vs twofold ring yarns, 356–8
    - breaking elongation, 358
    - tenacity, 357
    - twist liveliness, 357
- wrapper fibres, 84
- wrapping filament, 352
- wrapping pitch, 353
  
- X-ray photoelectron spectroscopy, 429
  
- Yantra PKVE spinning machine, 358
- yarn
  - classification according to structure, 168–72
    - cabled or cord yarns, 171
    - complex or core-spun yarns, 171

- fancy or novelty yarns, 171
- modified continuous filament yarns, 171–2
- ply or multifold yarns, 169–71
- single yarns, 168–9
- types of novelty yarns, 172
- fibre types and classification, 156
- manufacturing process interactions and effect on structure, 176–7
  - factors affecting migration, 176–7
  - fibre migration mechanisms, 176
  - fibre migration phenomenon, 176
- structural requirements for knitted and woven fabrics, 155–81, 182–9
  - criteria for choice of fibres and yarns, 179–80
  - fibre types and classification, 156
  - glossary and definitions, 182–9
  - principal requirements for knitted fabric end uses, 156–61
  - woven fabric end uses principal requirements, 161–6
- structure and properties from different spinning technologies, 119–51
  - air-jet spun yarns, 134–9
  - friction spun yarns, 141–6
  - future trends, 150–1
  - ring spun yarns, 120–6
  - rotor spun yarns, 126–34
  - staple fibre yarns, 149–50
  - staple spun yarns structure-property relationships, 147–9
  - wrap spun yarns, 146–7
  - survey of properties, 177–9
    - mechanical properties, 179
    - mechanical properties and standard test methods, 179
    - physical properties, 177
    - physical properties and standard test methods, 178
  - types and their classification, 167–75
    - bicomponent and biconstituent fibres formation, 169
    - direction twist and construction of plied and cord, 170
    - effect of twist on modulus and strength, 173
    - fibre type and content, 167–8
    - level of twist, 174
    - method of manufacturing, 175
    - twist, 172–5
- yarn balloon tension, 55
- yarn break, 63
- yarn breakage, 270–1
- yarn/drum friction force, 412
- yarn hairiness, 238–40, 251
- yarn production speed, 25
- yarn rewinding, 73
- yarn withdrawal, 268
  
- zero-twist length, 381
- zero-twist zone, 381–2
- Zinser 351 C, 247
- Zinser AIR-COM-TEX 700 system, 247
- ZinserCompACT, 254